

NOTICE DE MONTAGE



Assembling instructions
 Montage Anweisungen
 Montaje instructie
 Noticia de montagen
 Istruzioni per il montaggio
 Instruções de montaj

TRIGANO

N°123 039 Rev B

**Portiques TECHWOOD
 avec plate-forme - H 2,30m**

TRIGANO JARDIN
 Le Boulay
 41310 – Comenon, France

Références		 AGE (an-mois) AGE (year-month) ALTER IDADE LEEFTIJD ETA - EDAD
TE 608 - Réf.18620	120 mn	5 - 12
TE 801 - Réf.18880	150 mn	5 - 12
TE 802 - Réf.18780	150 mn	5 - 12
TE 702 - Réf.18720	150 mn	5 - 12
TE 902 - Réf.18955	150 mn	9 mois (siège bébé) 12 ans
TE 504 - Réf.18420	120 mn	5 - 12
TE 507 - Réf.18521	120 mn	5 - 12
TE 509 - Réf.18621	150 mn	5 - 12
TE 508 - Réf.18520	150 mn	5 - 12
TE 610 - Réf.18660	120 mn	5 - 12
TE 901 - Réf.18990	150 mn	9 mois (siège bébé) 12 ans
TE 804 - Réf.18870	150 mn	5 - 12
TE 705 - Réf.18760	150 mn	5 - 12
TE 805 - Réf.18860	150 mn	5 - 12



Pour bénéficier de votre garantie, déclarez celle-ci directement sur notre site internet
www.triganojardin.com

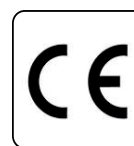
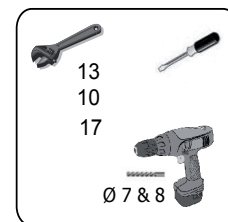

Attention ! – Warning – Achtung – Attenzione – Atencion - Atenção

- F** A LIRE **IMPERATIVEMENT** AVANT DE COMMENCER LE MONTAGE DE VOTRE PRODUIT - SCHELLEMENT BETON IMPERATIF
Réservé à un usage familial en extérieur.
- GB** IT IS **ESSENTIAL** TO READ THE MANUAL BEFORE STARTING TO ASSEMBLY YOUR PRODUCT - MUST BE FIXED IN CONCRETE
Only for domestic use, for outdoor.
- D** VOR DER MONTAGE DES ARTIKELS **UNBEDINGT** DURCHLESEN - MUSS UNBEDINGT EINBETONIERT WERDEN
Ausschließlich für den Privatgebrauch im Freien.
- NL** LEES DIT **VERPLICHT EN GRONDIG** DOOR VOORDAT U UW TOESTEL GAAT MONTEREN - HET IS NOODZAKELIJK TE BEVESTIGEN
MET GRONDANKERS. Uitsluitend voor gebruik in de gezinskring buitens huis.
- I** LEGGERE **ATTENTAMENTE** PRIMA DI INIZIARE IL MONTAGGIO DEL PRODOTTO - ESSERE FISSATO SALDAMENTE NEL CEMENTO
Sólo para uso doméstico en exteriores.
- SP** DE LECTURA **IMPRESINDIBLE** ANTES DE EMPEZAR CON EL MONTAJE DEL PRODUCTO - EMPOTRAMIENTO IMPERATIVO
Utilizzo esclusivamente familiare, per esterni.
- P** A LER **IMPERATIVAMENTE** ANTES DE COMECAR A MONTAGEM DO SEU PRODUTO - - O CHUMBAMENTO É IMPERATIVO
Exclusivamente para uso familiar no exterior.

- F** Veuillez garder impérativement la notice de montage qui vous sera utile pour l'entretien de votre produit. Aucune modification ne doit être apportée sur le produit. Pour l'entretien du produit n'utiliser que des pièces d'origine.
- G** It is imperative that you keep the assembling instructions, which be of use for product maintenance. Not to bring modifications to the product, and any change must be made with parts of origine.
- D** Bewahren Sie unbedingt die Montageanleitung auf, die Sie zur Wartung und Pflege Ihres Artikels brauchen.
- NL** Bewaar de gebruiksaanwijzing zorgvuldig, deze zal nuttig zijn voor het onderhoud van uw produkt.
- P** Guarde imperativamente as instruções de montagem, que serão úteis para a manutenção do seu produto.
- I** Conservare il manuale di montaggio per le ulteriori operazioni di manutenzione.
- SP** Conserve cuidadosamente las instrucciones de montaje, ya que le servirán para el mantenimiento de su producto.

- F** Zone de sécurité : 2,00 m.
- aucun objet en appui sur le produit
- Recouvrir le béton de 5 cm de terre meuble
- UK** Safety area : 2,00 m.
- No object around the product
- Cover the concrete dies with a 5cm layer of soil
- D** Sicherheitsbereich: 2,00 m.
- Kein Gegenstände in der Nähe der Rutsche belassen
- 5cm Rasenüberdeck ung erforderlich im Leiterbereich und im Auslaufbereich
- NL** Veiligheidszone : 2,00 m.
- Geen enkel voorwerp rondom het toestel
- Bedek de betonblokken met 5cm losse aarde
- I** Zona di sicurezza : 2,00 m.
- Nessun oggetto intorno al prodotto
- Ricoprire i dadi in cemento di 5cm terra mobile
- SP** Area de seguridad : 2,00 m.
- Ningún objeto alrededor del producto
- Recubrir el hormigón con 5cm de tierra blanda
- P** Zona de segurança : 2,00 m.
- Nenhum objecto em redor do produto
- Abranger o betão de 5cm de terra móvel.

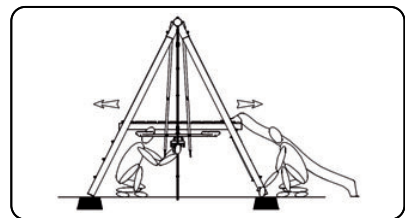
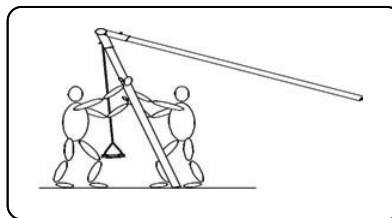
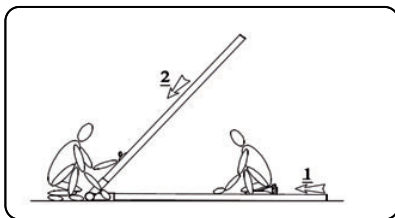
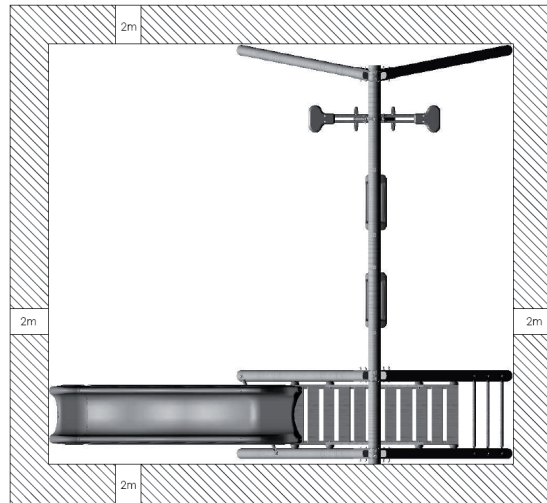

- Scellement béton impératif
- Must be fixed in concrete
- Muss unbedingt einbetoniert werden
- Het is noodzakelijk te bevestigen met grondankers
- O chumbamento é imperativo
- Essere fissato saldamente nel cemento
- Empotramiento imperativo

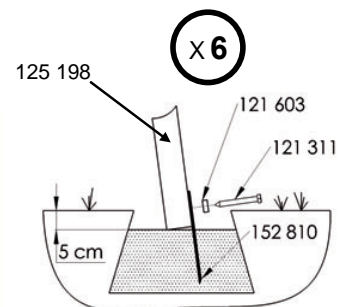
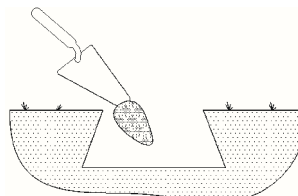
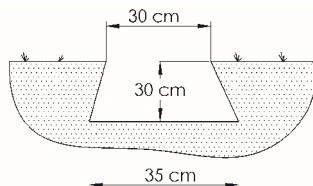

F - Votre balançoire est prévue pour être montée sur des portiques de hauteurs différentes. Avant d'utiliser votre portique et régulièrement par la suite, contrôler que le dessous du siège de balançoire est toujours compris entre **35 et 50cm** par rapport au sol. Si ce n'est pas le cas, procéder impérativement à ce réglage.

GB -Your swing is designed to be gone up on gantries of different sizes. Before using your gantry and regularly there after, controlling that the lower part of the seat of swing always lies between 35 and 50cm compared to the ground. If it is not the case, to carry out this adjustment imperatively.

D - Ihre Schaukel ist vorgesehen, um auf Säulenhallen anderer Größen aufgerichtet zu werden. Bevor Ihre Säulenhalle und regelmäßig später zu benutzen zu kontrollieren, dass die Unterseite des Schaukelsitzes immer zwischen 35 und 50 gelegen wird cm hinsichtlich des Bodens. Wenn es nicht der Fall, diese Einstellung dringend durchzuführen ist.

NL- Uw schommel is voorzien om op portalen van verschillende omvang gestegen te zijn. Alvorens uw portaal te gebruiken en regelmatig vervolgens, controleren dat de onderkant van de zetel van schommel altijd tussen 35 en 50cm ten opzichte van de bodem wordt omvat. Als het niet het geval, verplicht tot dit regelen overgaan is.

I - La vostra altalena è prevista per essere montata su cavalletti di dimensioni diverse. Prima di utilizzare il vostro cavalletto e regolarmente successivamente, controllare che il sotto della sede d'altalena è sempre compreso tra 35 e 50cm rispetto al suolo. Se non è il caso, procedere imperativamente a questa messa a punto.

SP - Su columpio está previsto subirse sobre pórticos de tamaños diferentes. Antes de utilizar su pórtico y regularmente más tarde, controlar que la parte inferior de la sede de columpio siempre se incluye entre 35 y 50cm con relación al suelo. Si no es el caso, proceder imperativamente a este ajuste.

P - O vosso baloiço está previsto para ser montado sobre pórtico de dimensões diferentes. Antes de utilizar o vosso pórtico e regularmente seguidamente, controlar que o abaixo da sede de baloiço sempre é compreendido entre 35 e 50 cm em relação ao solo. Se não é o caso, proceder imperativamente à este ajustamento.

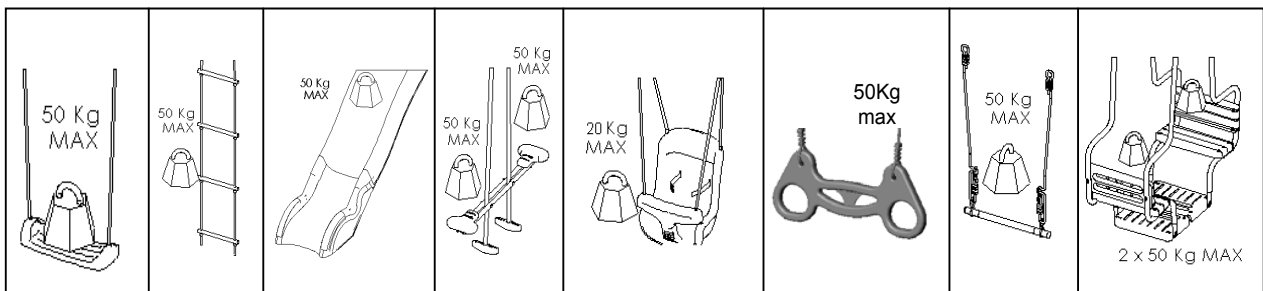
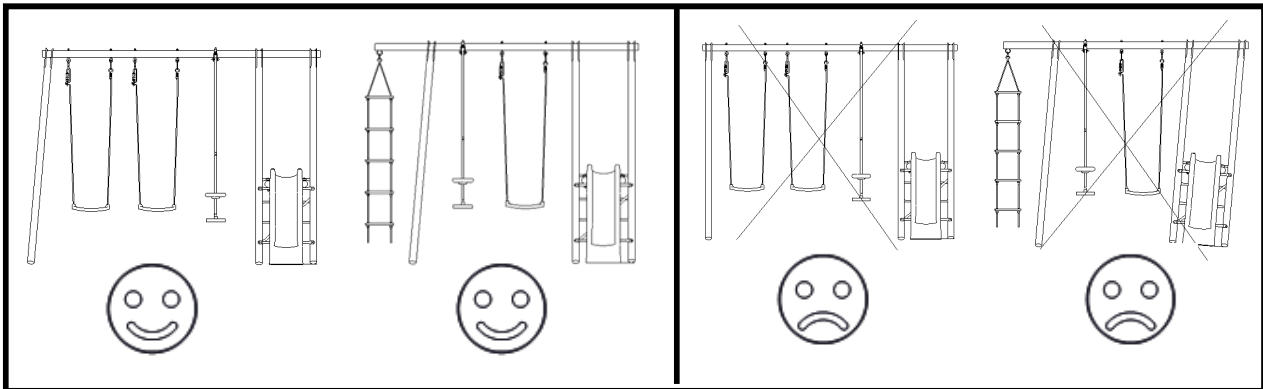
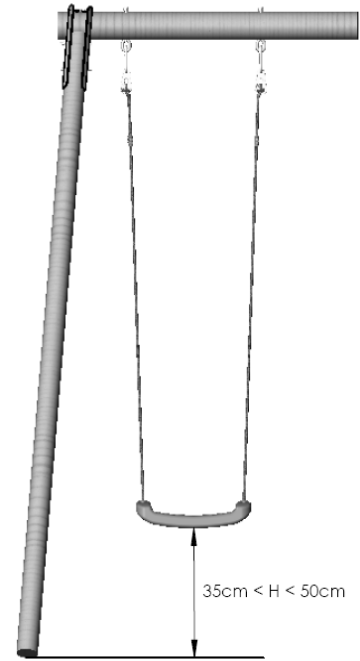

Pour plus d'informations, vous pouvez vous rendre sur notre site internet **WWW.TRIGANOJARDIN.COM**

FR - Pour mesurer les écartements entre les pieds avant de faire vos plots de scellement, tirer modérément les pieds vers l'extérieur du portique pour être sûr d'obtenir l'angle de 95° minimum (comme figure ci-contre).

GB - Pull the feet a little bit away from the frame to ensure the angle is at least 95° (see figure below) before measuring the distance between the feet and making your mounting blocks.

DE - Um den Abstand zwischen den Füßen zur Bestimmung der Verankerungspunkte zu bemessen, die Füße des Gerüsts leicht nach außen ziehen, um sicherzugehen, dass der Winkel mindestens 95° beträgt (siehe Abbildung oben).

NL - Voor u de afstandblokkjes vastmaakt, moet de afstand ertussen gemeten worden. Trek zachtjes de poten naar de buitenzijde van de speelconstructie zodat u een minimale hoek van 95° hebt (zie figuur hierboven).

ES - Para medir las separaciones entre los pies antes de realizar sus juntas de sellado, tire moderadamente de los pies hacia afuera del pórtico para asegurarse de que tiene un ángulo de 95° como mínimo (como figura más arriba).

IT - Per misurare lo scarto tra i piedi prima di procedere al fissaggio definitivo, tirare con moderazione i piedi verso l'esterno della struttura per essere sicuri di avere un angolo di minimo 95° (come mostrato dalla figura qui sopra).

PO - Para medir as distâncias entre os pés antes de fazer os blocos de fixação, puxar moderadamente os pés para o exterior do pórtico para ter a certeza de ter um ângulo de 95° mínimo (como figura acima).

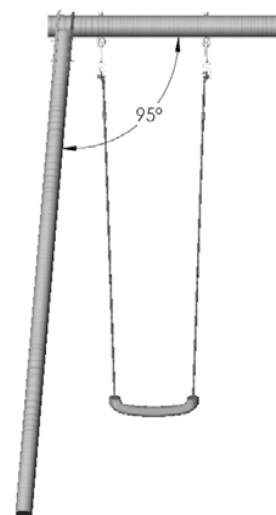

F Nous vous précisons que le bois est un produit naturel qui réagit aux variations de température et d'humidité. Des fissures et des fentes peuvent apparaître. C'est tout à fait normal et cela n'affecte en rien la solidité, la durée de vie ou la garantie de ce produit.

UK Please be aware, wood is a natural product that re-acts to temperature and humidity variations. Splits and cracks will occur. This is completely normal and does not affect the integrity of your product or your warranty.

D Wir erinnern Ihnen, dass das Holz natürlich ist. Es kann sein, dass einige Ritze wegen Feuchtigkeitsveränderungen erscheinen. Das ist ganz normal und das verschlechtert überhaupt nicht die Festigkeit, Lebensdauer oder die Garantie dieses Produkts.

NL Wij wijzen er op dat hout een natuurlijk product is dat reageert op temperatuur-en vochtigheidsverschillen. Er kunnen scheurtjes en gleuven optreden. Dit is normaal en doet niets af aan de degelijkheid, de levensduur of de garantie van dit product.

I Indicamos-lhe que a madeira é um produto natural que reage às variações de temperatura e de humidade. Rachas e fendas podem aparecer. É normal e isso não afecta em nada a solidez, a duração de vida ou a garantia deste produto.

SP Precisiamo che il legno è un prodotto naturale che reagisce alle variazioni di temperatura e di umidità. Possono apparire delle fessure e delle crepe. Ciò è del tutto normale e non ha alcun effetto sulla solidità, la durata di vita o la garanzia di questo prodotto.

P Le recordamos que la madera es un producto natural que reacciona a las variaciones de temperatura y humedad. Pueden aparecer fisuras o grietas. Es normal y no afecta en absoluto a la solidez, la vida útil o la garantía del producto.

F – Procéder à l'assemblage des pièces avec la visserie, **sans serrer**. Une fois assemblé entièrement, serrer définitivement toutes les vis. Ensuite, sceller **impérativement** votre portique. Pour un portique 6 pieds, l'angle formé par la poutre et les 4 pieds formant la plate-forme doit être de 90°. Par contre l'angle formé par la poutre et les 2 pieds restants doit être au moins de 95° vers l'extérieur. Le non respect de ces consignes risque d'endommager votre produit et annulera la garantie.

GB – Use the screws to assemble the pieces but without **tightening them**. Once entirely assembled tighten all the screws definitively. It is then **essential** to firmly anchor your frame. For frames with 6 legs the angle between the beam and the 4 legs forming the platform should be 90°. However, the outer angle between the beam and the 2 remaining legs should be.

DE – Die Einzelteile mit Hilfe der Schrauben zusammenbauen, dabei die Schrauben **erst nur lose anziehen**. Sobald alles zusammengabaut wurde, alle Schrauben festziehen. Anschließend muss das Gerüst **unbedingt** fest verankert werden. Bei einem Gerüst mit 6 Füßen muss der Winkel zwischen dem Balken und den 4 Füßen, die die Plattform bilden, 90° betragen. Allerdings muss der Außenwinkel zwischen dem Balken und den beiden verbleibenden Füßen mindestens 95° betragen. Wenn diese Vorschriften nicht beachtet werden, besteht das Risiko, dass der Artikel beschädigt wird und die Garantie erlischt.













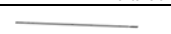
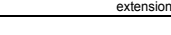
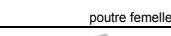

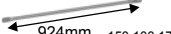

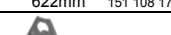
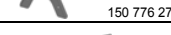

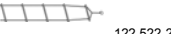

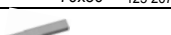
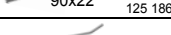
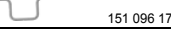



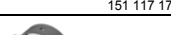

NL – Ga verder met het samenstellen, stuk per stuk, door gebruik te maken van de schroeven, **zonder deze aan te draaien**. Wanneer alles gemonteerd is, kunt u de schroeven complete aandraaien. Maak hierna uw speelconstructie heel stevig vast. Bij een speelconstructie met 6 poten, moet de hoek gevormd door de balk en de 4 poten die het platform ondersteunen, 90° zijn. Bovendien moet de hoek gevormd door de balk en de resterende 2 poten, 95° zijn naar buiten toe.

ES – Proceda a ensamblar las piezas con tornillos y pernos, **sin ajustar**. Una vez que haya realizado el ensamblado completo, ajuste definitivamente todos los tornillos. A continuación, es **obligatorio** que selle el portico. Para un pórtico 6 pies, el ángulo entre la viga y los 4 pies que forman la plataforma debe ser de 90°. En cambio, el ángulo formado por la viga y los 2 pies restantes debe ser, como mínimo, de 95° hacia el exterior.

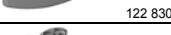



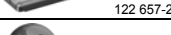
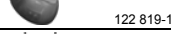

























IT – Procedere all'assemblaggio dei pezzi con viti e bulloni, **senza stringere**. Una volta completato l'assemblaggio, stringere definitivamente tutte le viti. In seguito, sigillare **obbligatoriamente** la struttura. Per una struttura a 6 piedi, l'angolo formato dalla trave e dai 4 piedi della piattaforma deve essere di 90°. L'angolo formato dalla trave e dai 2 rimanenti piedi deve invece essere di almeno 95° verso l'esterno.

PO – Procederà montagem das peças com os parafusos, **sem apertar**. Umavez montado completamente apertar definitivamente todos os parafusos. Em seguida, fixar **imperativamente** o seu pórtico. Para o pórtico 6 pés, o ângulo formado pela trave e os 4 pés que formam a plataforma deve ser de 90°. Por outro lado, o ângulo formado pela trave e os 2 pés restantes deve ser de pelo menos 95° para exterior.

TECHWOOD 2,30m

	TE608 18620	TE801 18680	TE802 18780	TE702 18720	TE902 18955	TE504 18420	TE507 18521	TE509 18621	TE508 18520	TE610 18680	TE901 18990	TE804 18870	TE705 18760	TE805 18860
 poutre mâle	150 031 18	150 031 18	150 031 18	150 031 18	150 031 18	150 030 18	150 030 18	150 030 18	150 030 18	150 033 18	150 033 18	150 033 18	150 033 18	150 035 18
 extension	-	150 785 18	150 785 18	-	150 785 18	-	150 785 18	150 785 18	-	-	150 785 18	150 785 18	-	-
 extension	-	151 157 18	-	-	151 157 18	-	-	-	-	-	151 157 18	-	-	-
 poutre femelle	150 034 18	150 034 18	150 034 18	150 034 18	150 034 18	150 036 18	150 036 18	150 036 18	150 036 18	150 034 18	150 034 18	150 034 18	150 034 18	150 034 18
 125 198	6	6	6	6	6	6	6	6	6	6	6	6	6	6
 924mm 150 100 17	1	1	1	1	1	1	1	1	1	1	1	1	1	1
 622mm 151 108 17	4	4	4	4	4	4	4	4	4	4	4	4	4	4
 150 776 27	6	6	6	6	6	6	6	6	6	6	6	6	6	6
 152 810	6	6	6	6	6	6	6	6	6	6	6	6	6	6
 122 522-2	-	1	1	-	1	-	1	1	-	-	1	1	-	-
 70x30 125 207	2	2	2	2	2	2	2	2	2	2	2	2	2	2
 90x22 125 186	10	10	10	10	10	10	10	10	10	10	10	10	10	10
 151 096 17	-	-	-	-	-	-	-	-	-	4	4	4	4	4
 152 818 17	-	-	-	-	-	-	-	-	-	2	2	2	2	2
 151 168 17	2	2	2	2	2	-	-	-	-	-	-	-	-	2
 151 117 17	2	2	2	2	2	-	-	-	-	-	-	-	-	2
 150 774 18	1	1	1	1	1	-	-	-	-	2	2	2	2	3
 150 775 18	1	1	1	1	1	-	-	-	-	2	2	2	2	3
 122 812	1	1	1	1	1	1	1	1	1	1	1	1	1	1
 122 814	1	1	1	1	1	1	1	1	1	1	1	1	1	1
 122 830	2	2	2	2	2	-	-	-	-	-	-	-	-	2
 122 840-1	4	4	4	4	4	4	4	4	4	4	4	4	4	4
 122 502-1	2	2	2	2	2	-	-	-	-	-	-	-	-	2
 122 519-1	-	-	-	-	-	-	-	-	-	2	2	2	2	2
 122 657-2	-	-	-	-	-	-	-	-	-	4	4	4	4	4
 122 819-1	4	4	4	4	4	4	4	4	4	4	4	4	4	4
 122 845	2	2	2	2	1	2	2	2	2	2	1	2	2	2
 151 020	2	2	2	2	2	2	2	2	2	2	2	2	2	2
 126002 A ou 126 002 B	2	1	1	2	1	2	1	1	2	2	1	1	2	2
 126 003	-	-	-	1	-	-	-	-	1	-	-	-	1	-
 126 053	-	-	1	-	1	-	-	1	-	-	1	1	-	-
 480	-	1	-	-	1	-	-	-	-	-	1	-	-	-
 9720	-	-	-	-	1	-	-	-	-	-	1	-	-	-

TECHWOOD 2,30m

	TE608 18620	TE801 18880	TE802 18780	TE702 18720	TE902 18955	TE504 18420	TE507 18521	TE509 18621	TE508 18520	TE610 18680	TE901 18990	TE804 18870	TE705 18760	TE805 18860
 126 000	-	-	-	1	-	-	-	-	1	-	-	-	1	-
 152 623	-	-	-	4	-	-	-	-	4	-	-	-	4	-
 Ø6x16 - 121 001	2	2	2	2	2	2	2	2	2	2	2	2	2	2
 Ø6x35 - 121 008	2	2	2	2	2	2	2	2	2	6	6	6	6	6
 Ø6x45 - 121 011	2	2	2	2	2	-	-	-	-	8	8	8	8	10
 Ø6x55 - 121 013	4	4	4	4	4	-	-	-	-	-	-	-	-	4
 Ø8x50 - 121 021	-	-	-	-	-	-	-	-	-	4	4	4	4	4
 Ø6x20 - 121 100	6	6	6	6	6	6	6	6	6	6	6	6	6	6
 Ø8x20 - 121 110	2	2	2	2	2	-	-	-	-	4	4	4	4	6
 Ø6x45 - 121 306	-	-	-	10	-	-	-	-	10	-	-	-	10	-
 Ø8x100 - 121 134	21	21	21	21	21	20	20	20	20	22	22	22	22	23
 Ø8x70 - 121 030	2	2	2	2	2	-	-	-	-	-	-	-	-	2
 Ø8x55 - 121 209	2	2	2	2	2	-	-	-	-	4	4	4	4	6
 121 311	16	16	16	16	16	16	16	16	16	16	16	16	16	16
 121 313	4	4	4	4	4	4	4	4	4	4	4	4	4	4
 405 307	44	44	44	44	44	44	44	44	44	44	44	44	44	44
 aglo 4,5x35 121 354	16	16	16	24	16	16	16	16	24	16	16	16	24	16
 VBA 3,5x25 121 303	8	8	8	8	8	8	8	8	8	8	8	8	8	8
 Ø8 - 121 505	21	21	21	21	21	20	20	20	20	22	22	22	22	23
 Ø6 - 121 511	16	16	16	16	16	10	10	10	10	22	22	22	22	28
 Ø8 - 121 512	27	27	27	27	27	20	20	20	20	34	34	34	34	41
 Ø5 - 121 658	8	8	8	8	8	8	8	8	8	8	8	8	8	8
 Ø6 - 121 602	40	40	40	58	40	34	34	34	52	46	46	46	46	52
 Ø8 - 121 603	67	67	67	67	67	60	60	60	60	78	78	78	78	85
 nylon Ø8 121 609	2	2	2	2	2	-	-	-	-	4	4	4	4	6
 Ø8 - 121 613	1	1	1	1	1	-	-	-	-	2	2	2	2	3
 122 037	4	7	5	4	7	4	5	5	4	4	7	5	4	4
 122 535	2	2	2	2	2	2	2	2	2	2	2	2	2	2
 122 506	4	4	4	4	4	-	-	-	-	8	8	8	8	12
 122 536	2	2	2	2	2	-	-	-	-	4	4	4	4	6
 122 623	4	4	4	4	4	-	-	-	-	8	8	8	8	12
122 539	-	-	-	-	-	-	-	-	-	4	4	4	4	4

TE 608
REF : 18 620

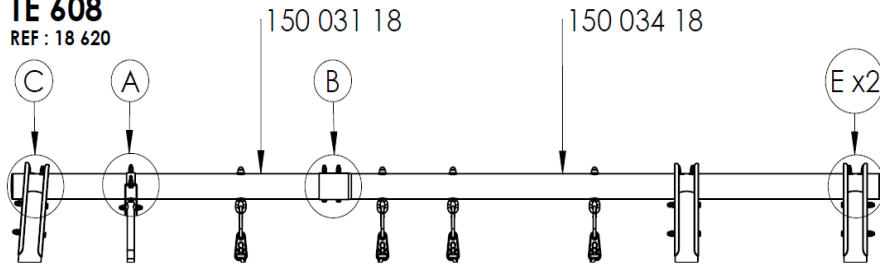

TE 801
REF : 18 880

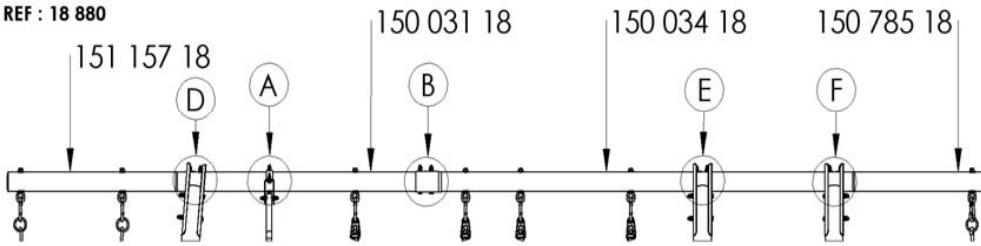

TE 802
REF : 18 780

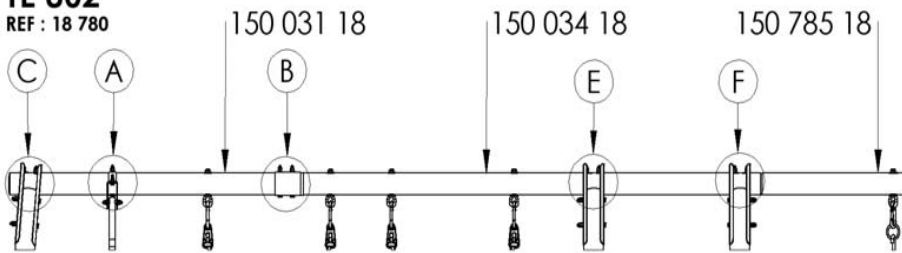

TE 702
REF : 18 720

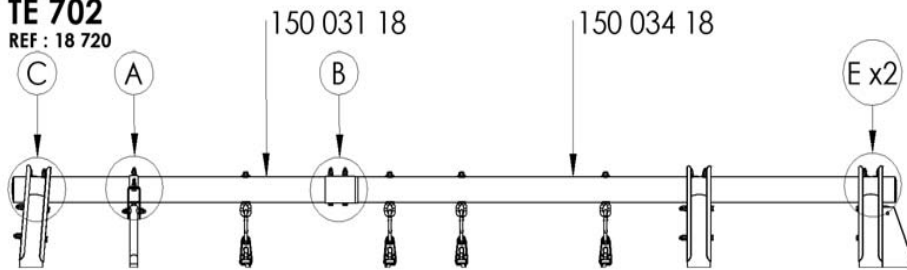

TE 902
REF : 18 955

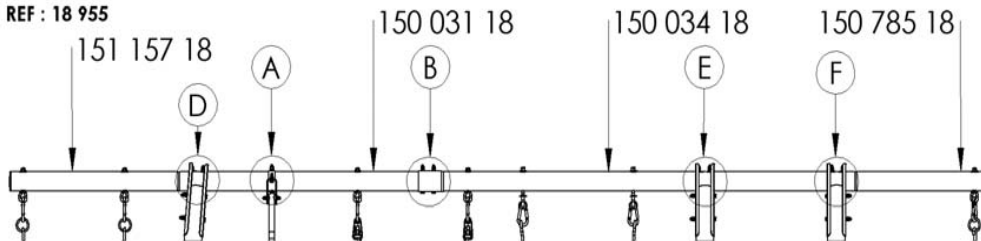

TE 504

REF : 18 420

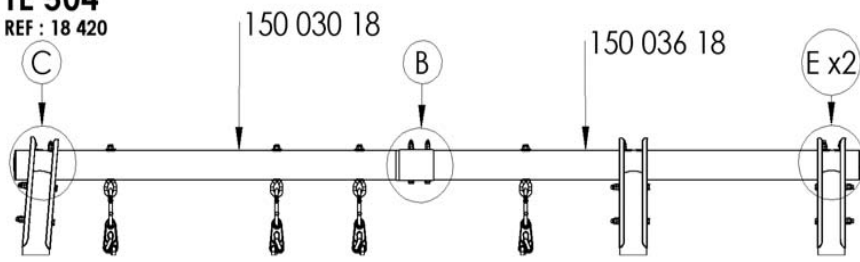

TE 507

REF : 18 521

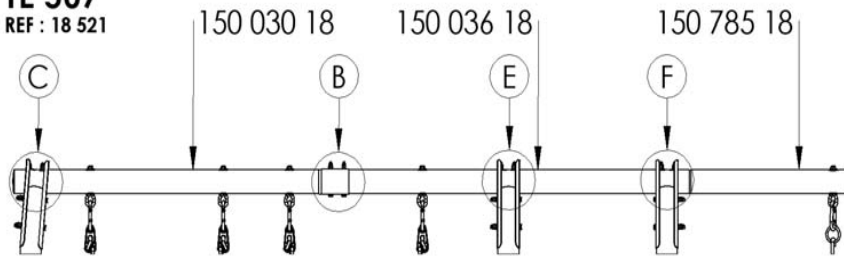

TE 509

REF : 18 621

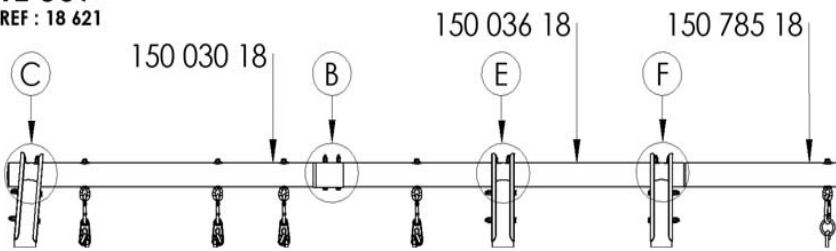

TE 508

REF : 18 520

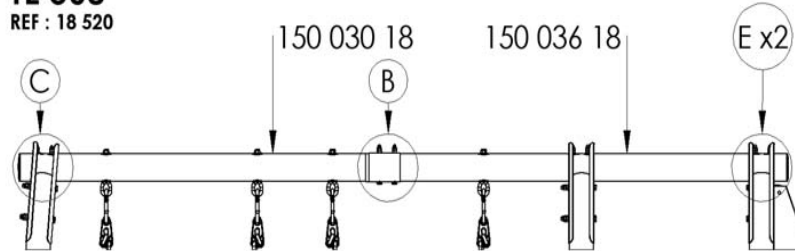

TE 610

REF : 18 660

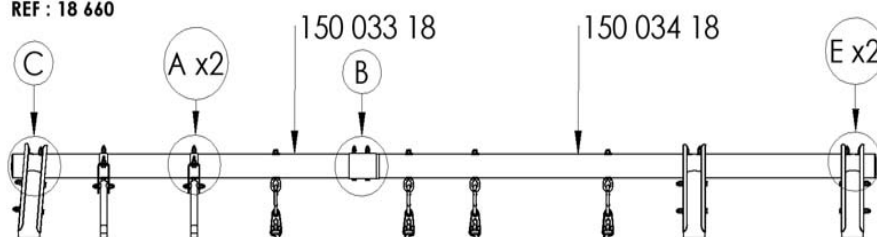

TE 901

REF : 18 990

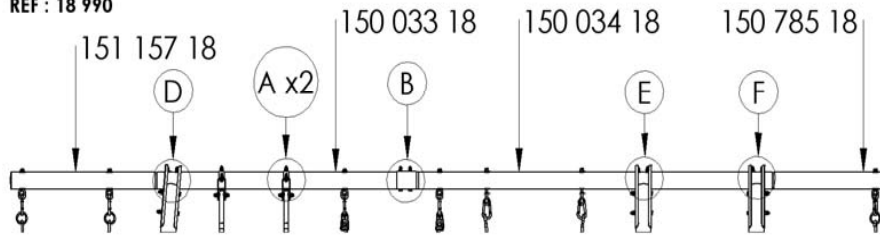

TE 804

REF : 18 870

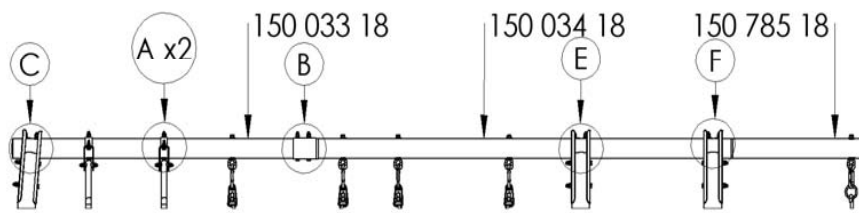

TE 705

REF : 18 760

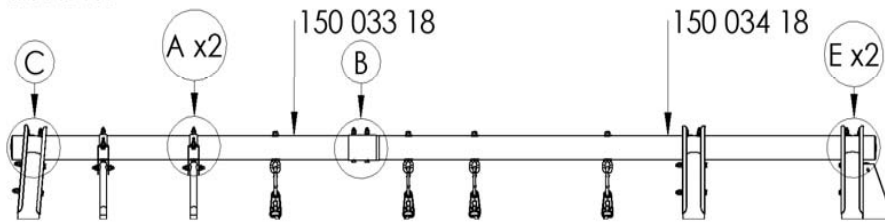

TE 805

REF : 18 860

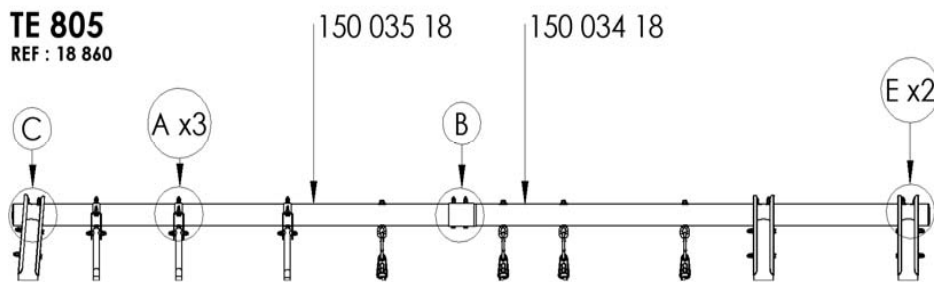

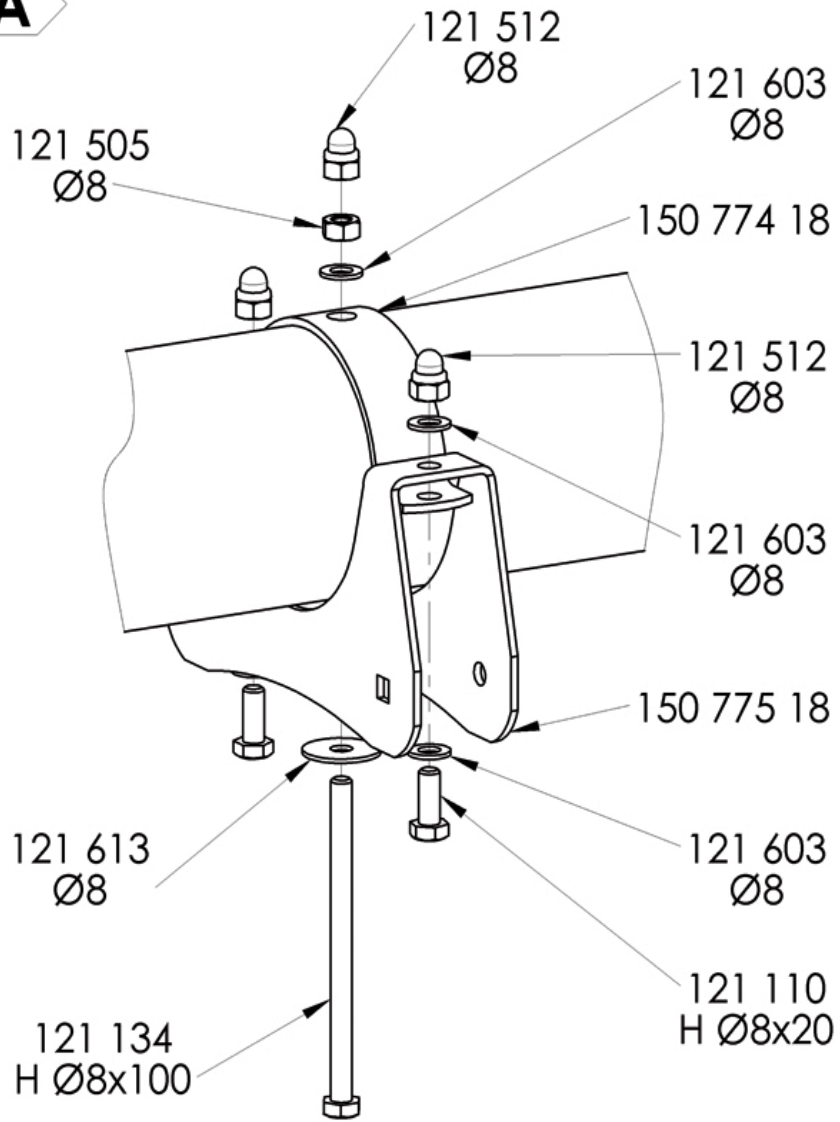
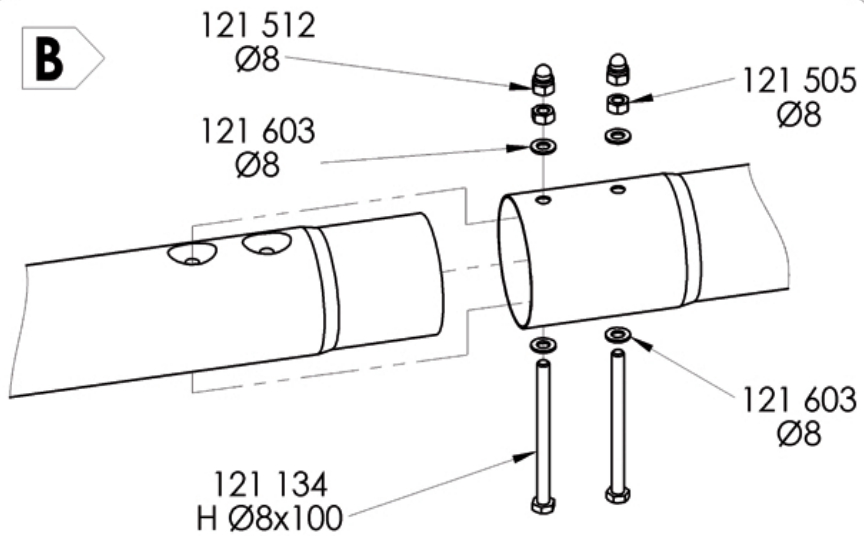
A**B**

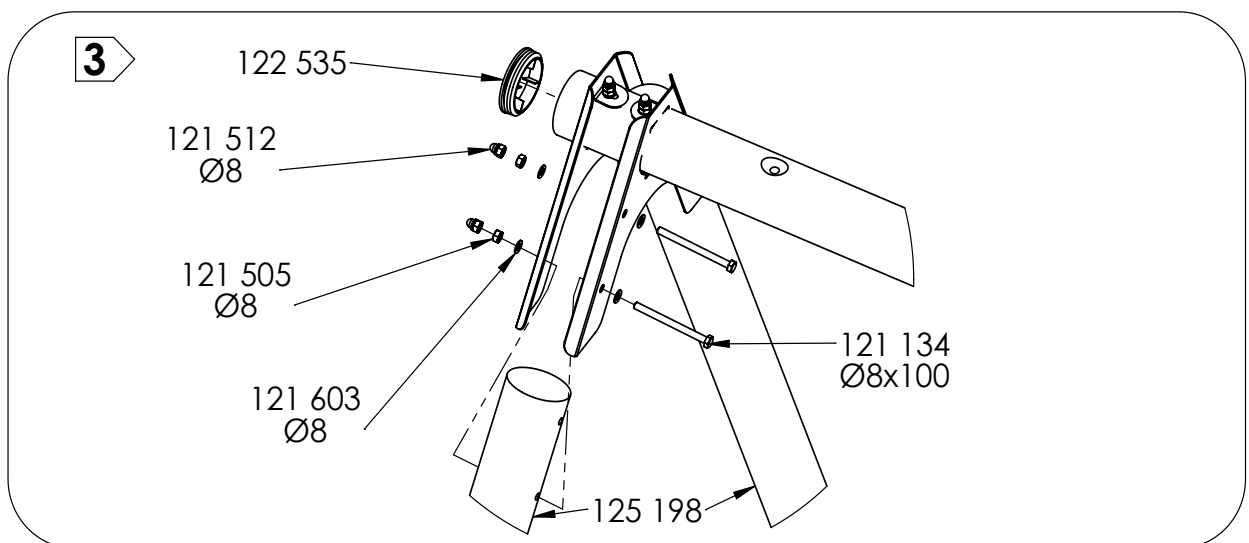
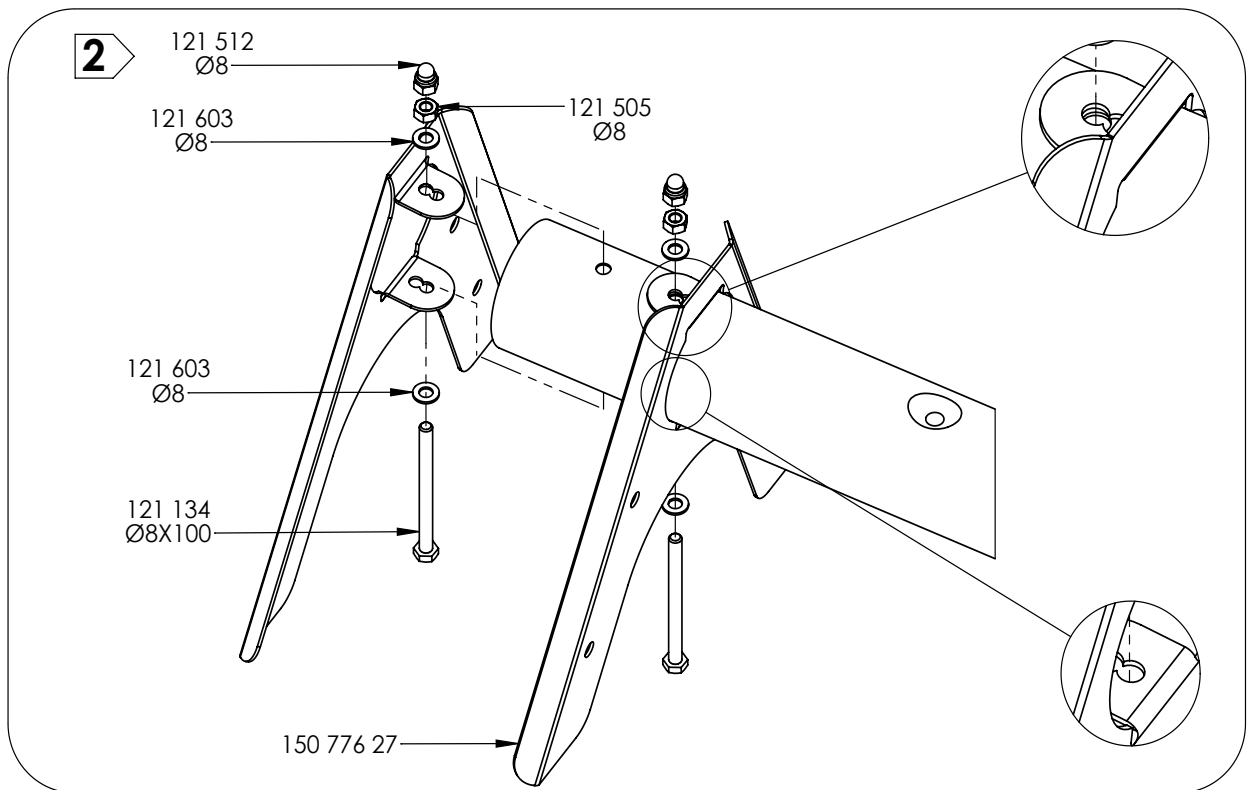
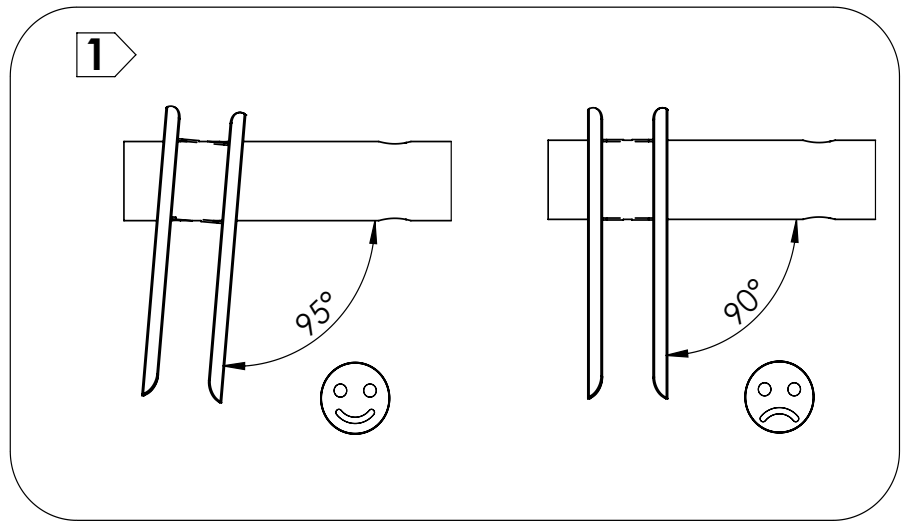
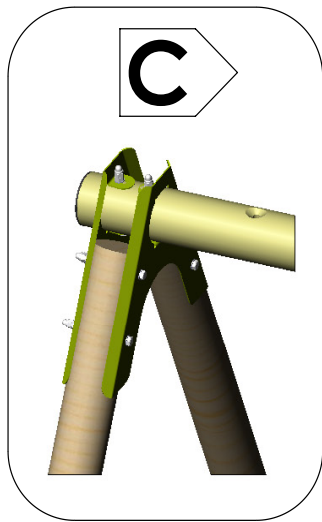

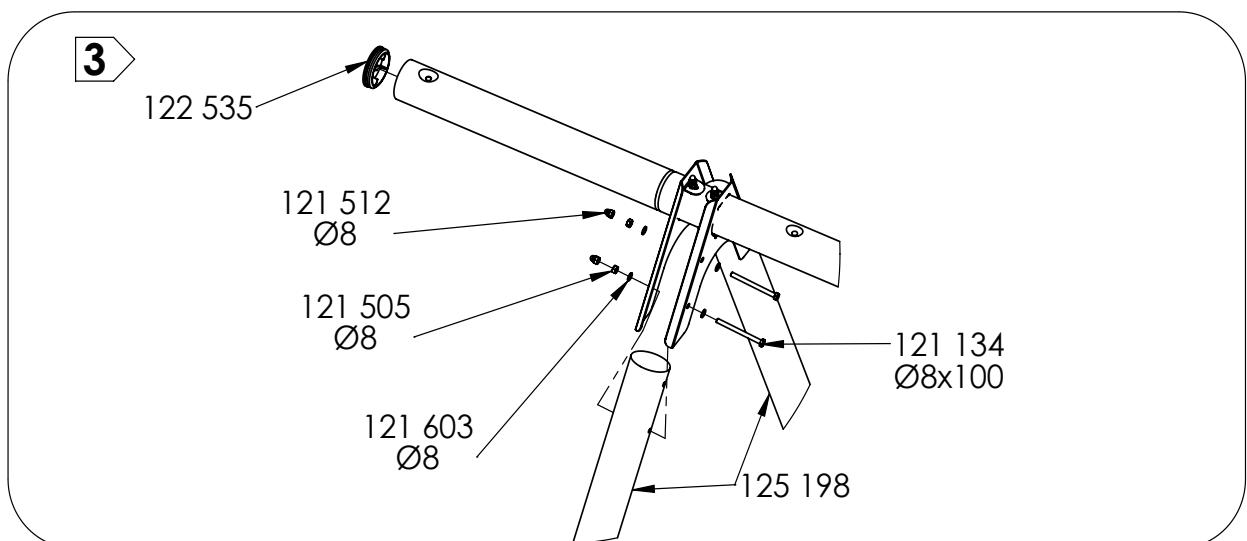
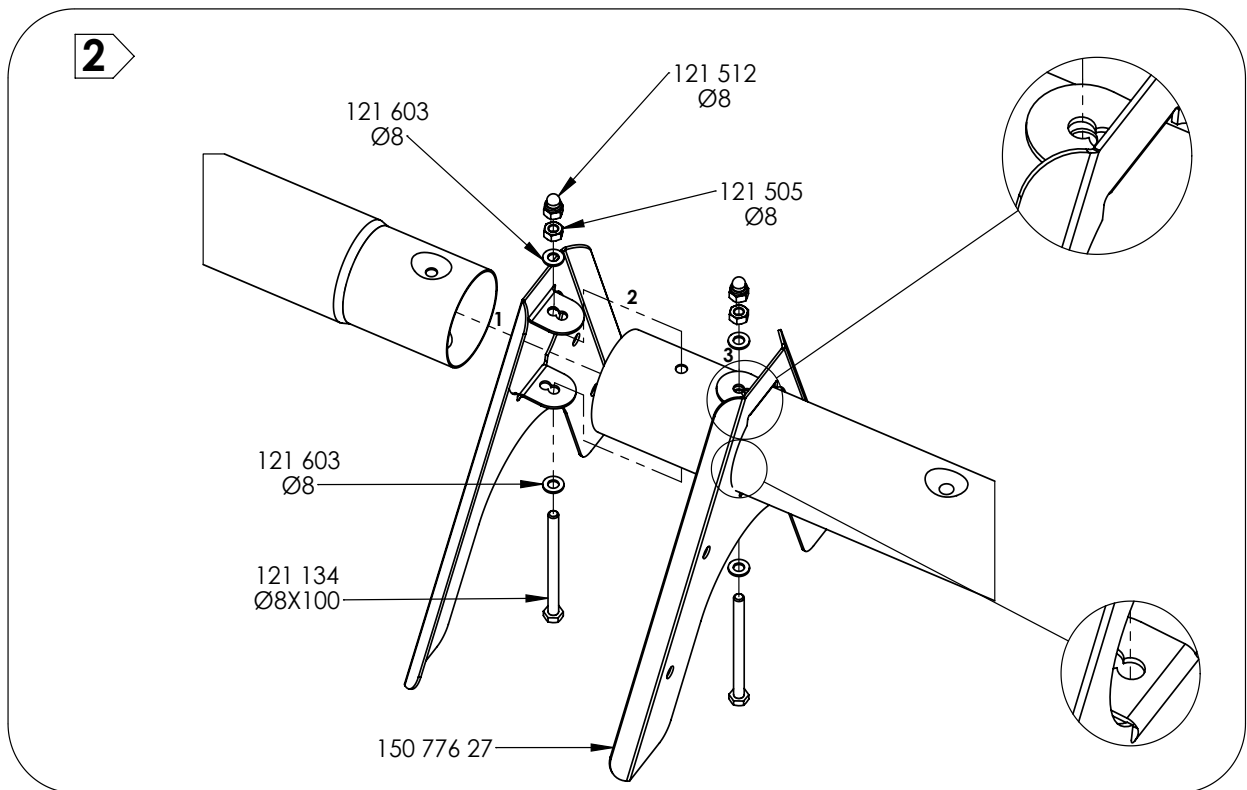
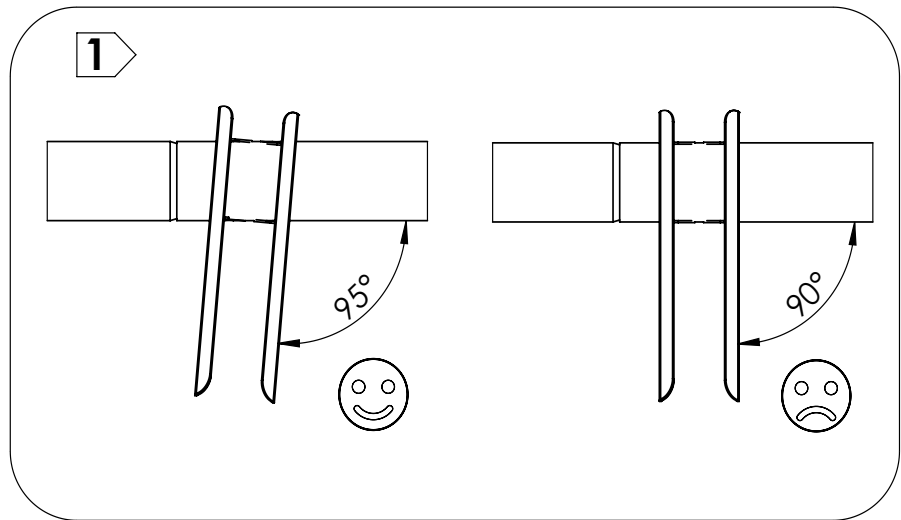
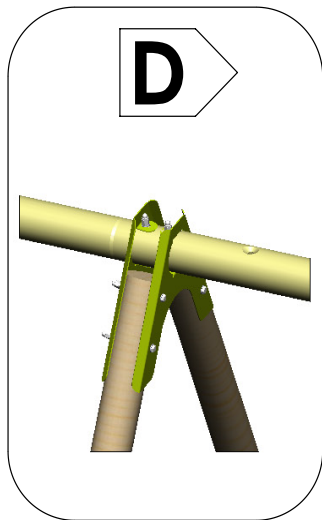

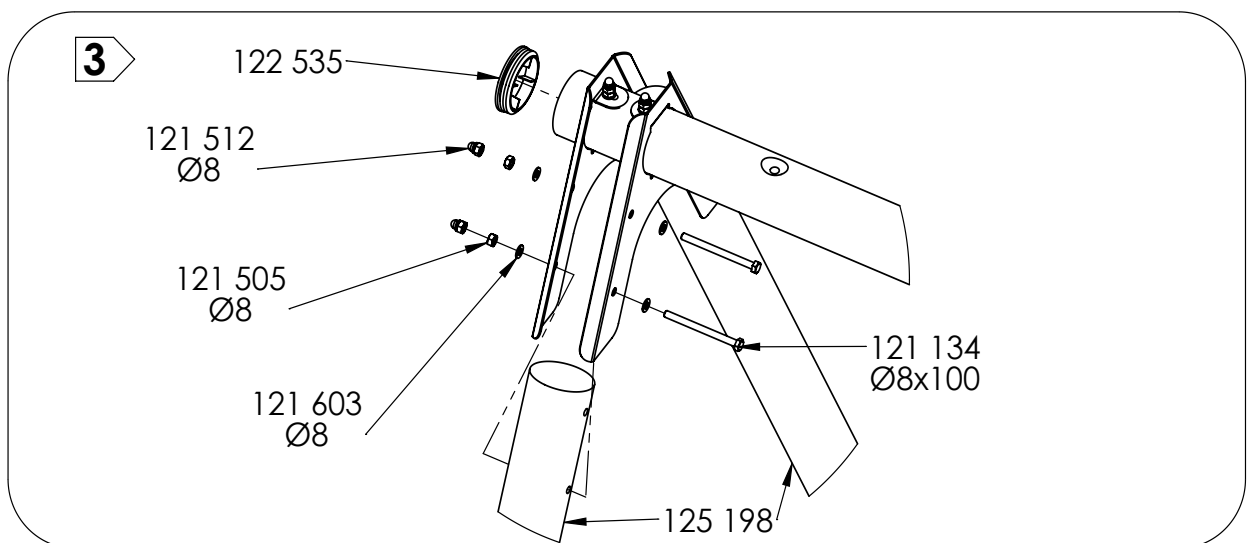
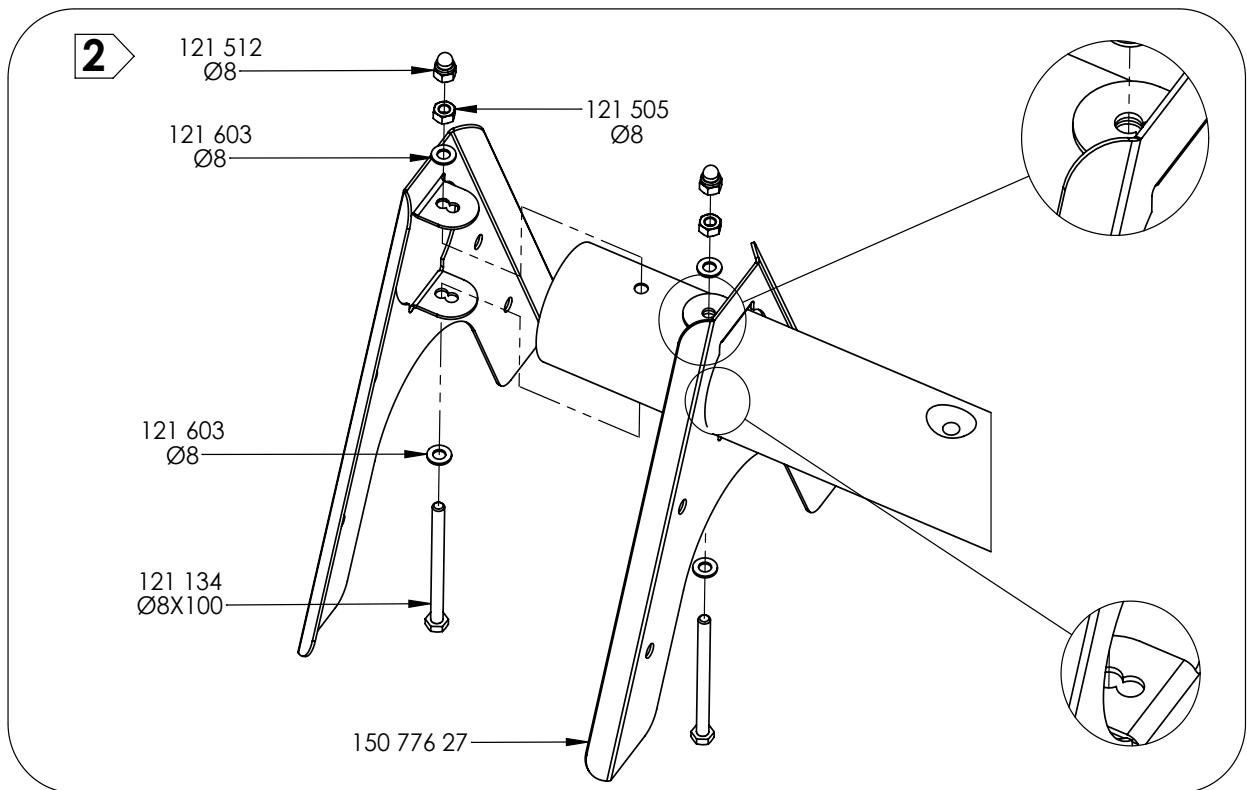
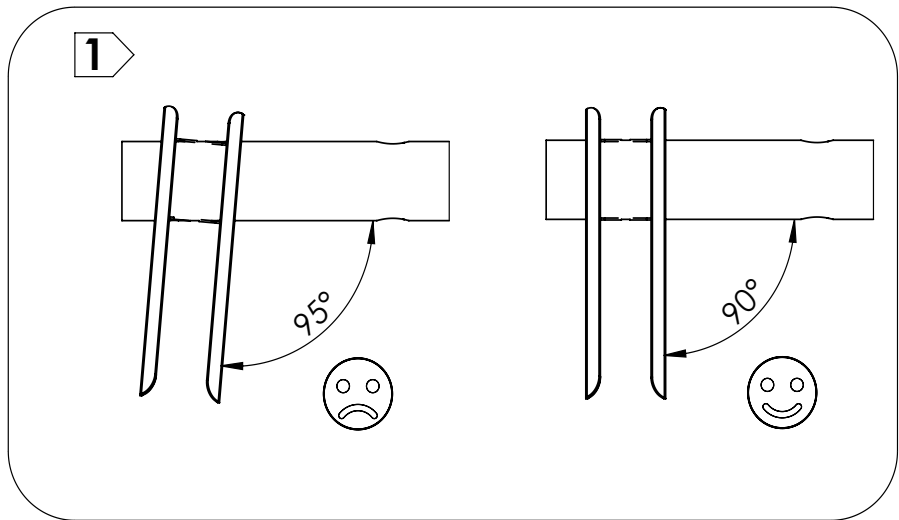
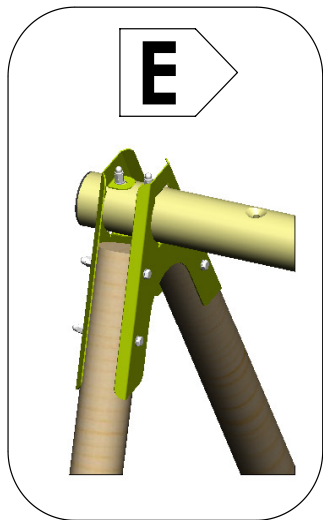

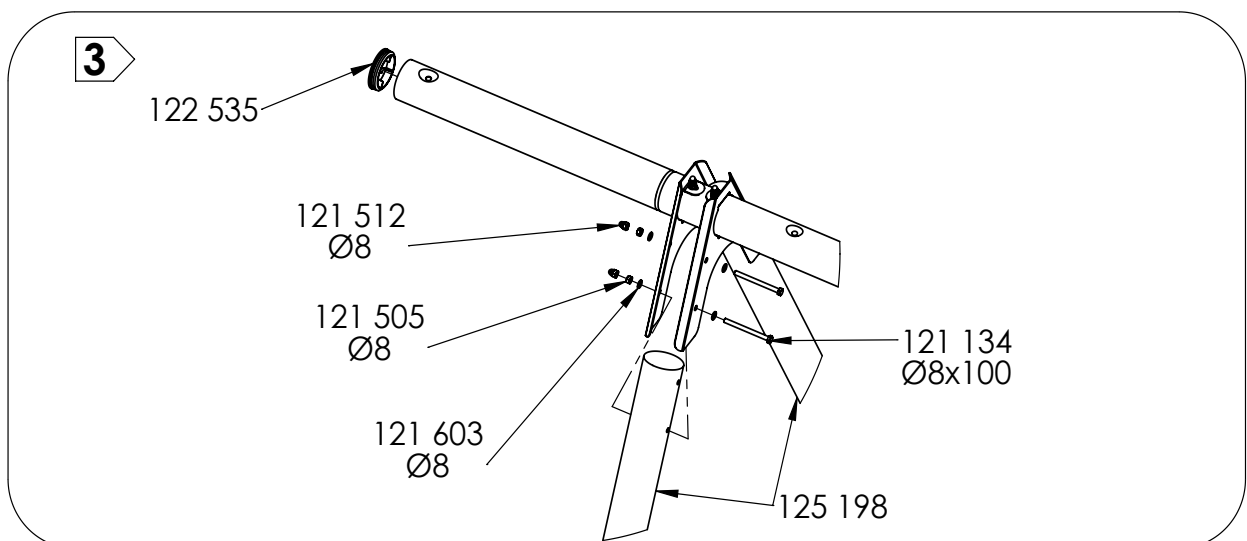
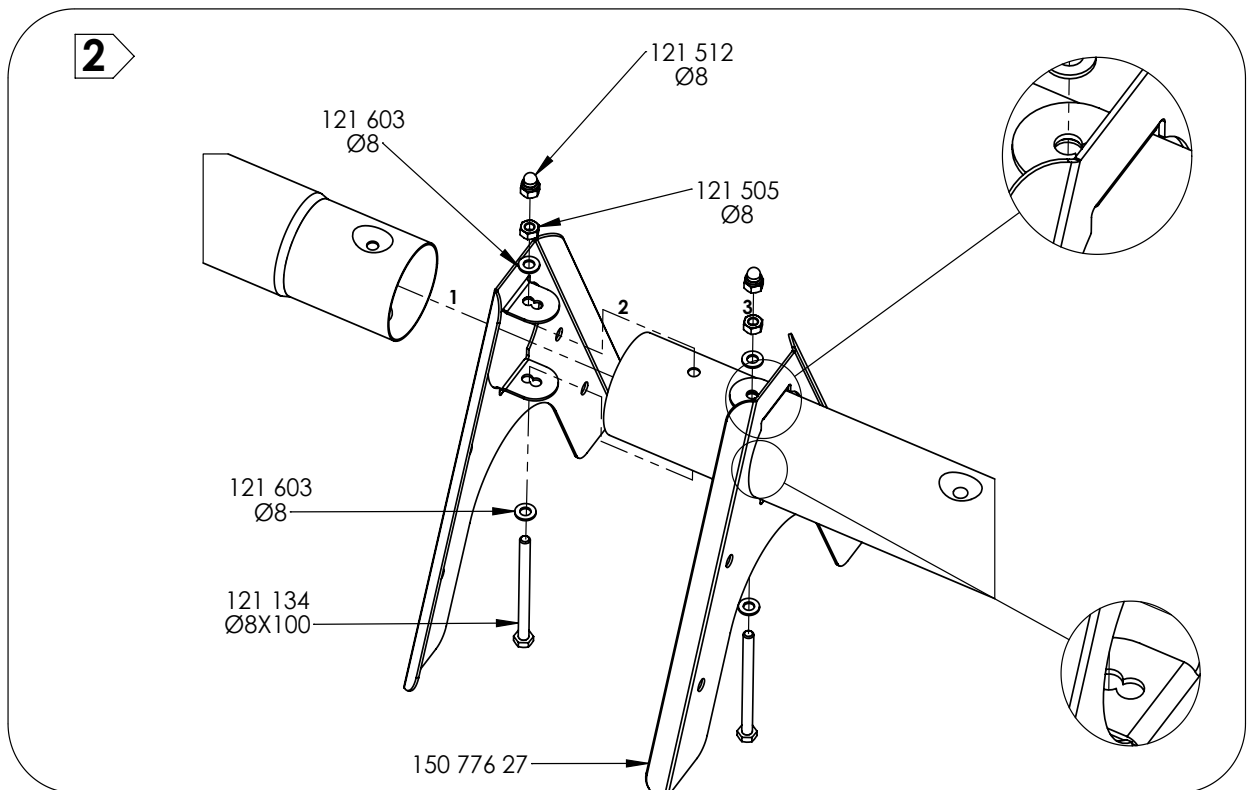
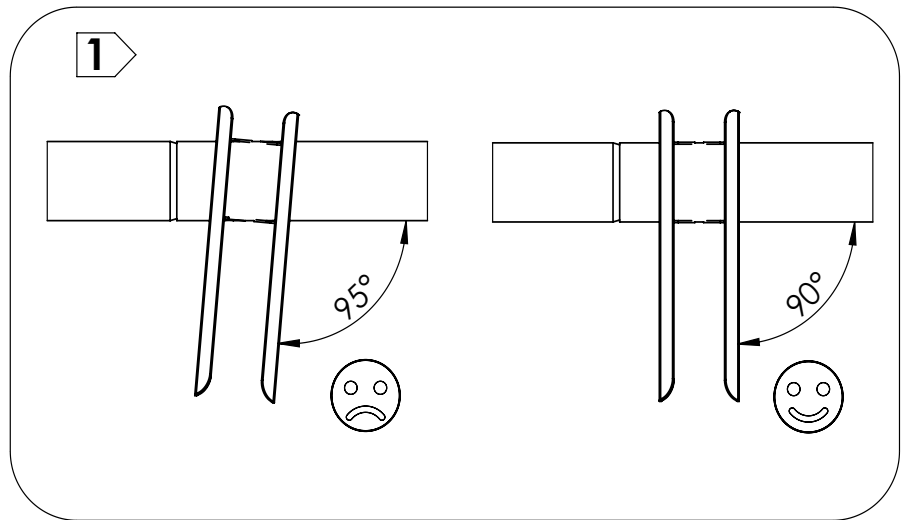
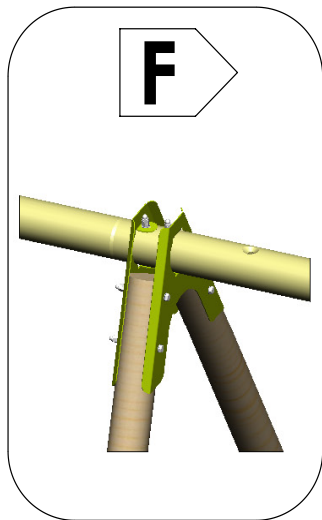

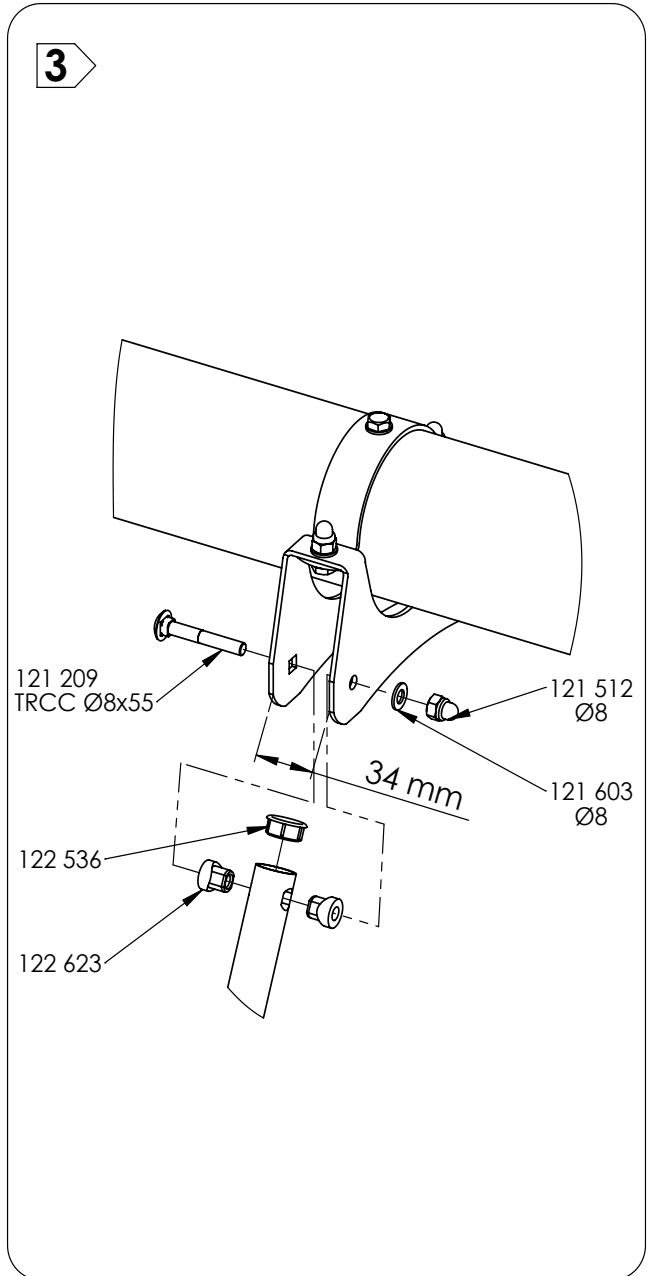
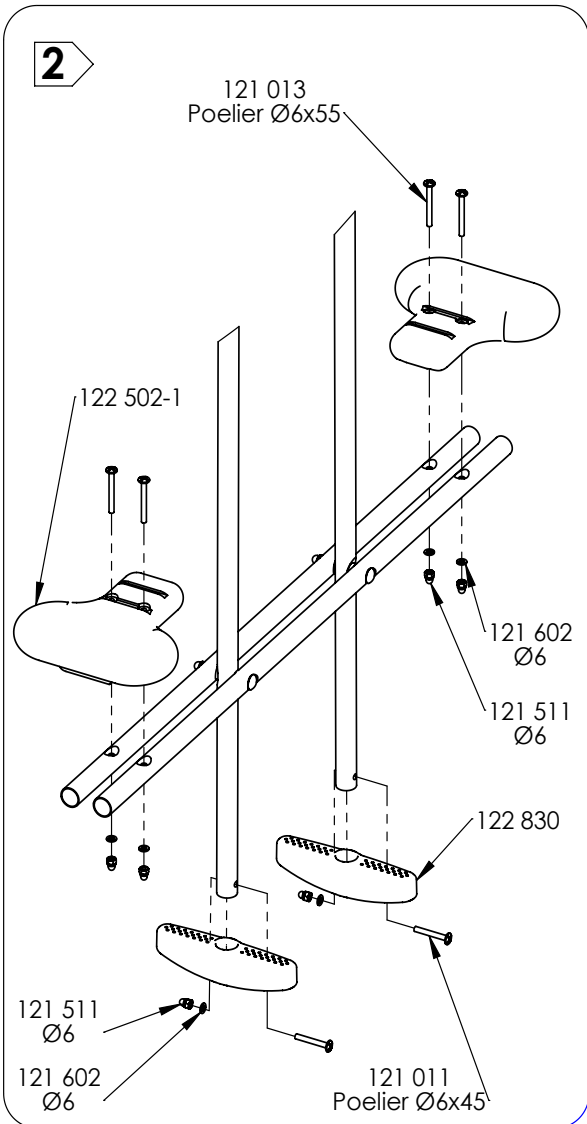
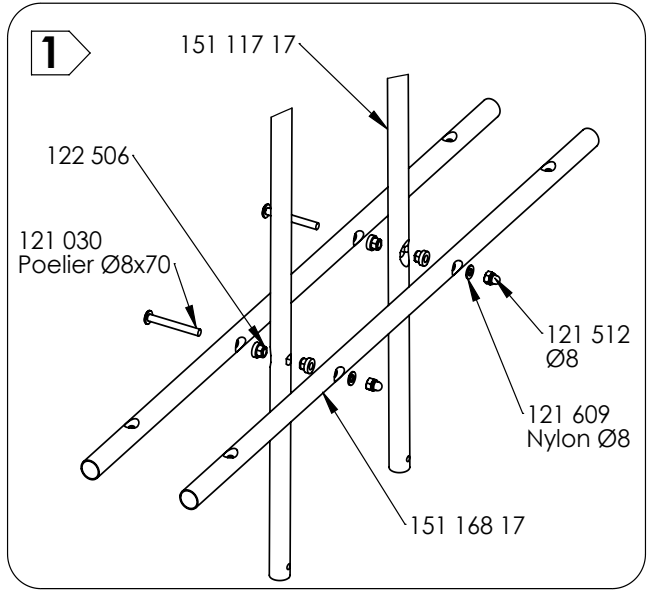

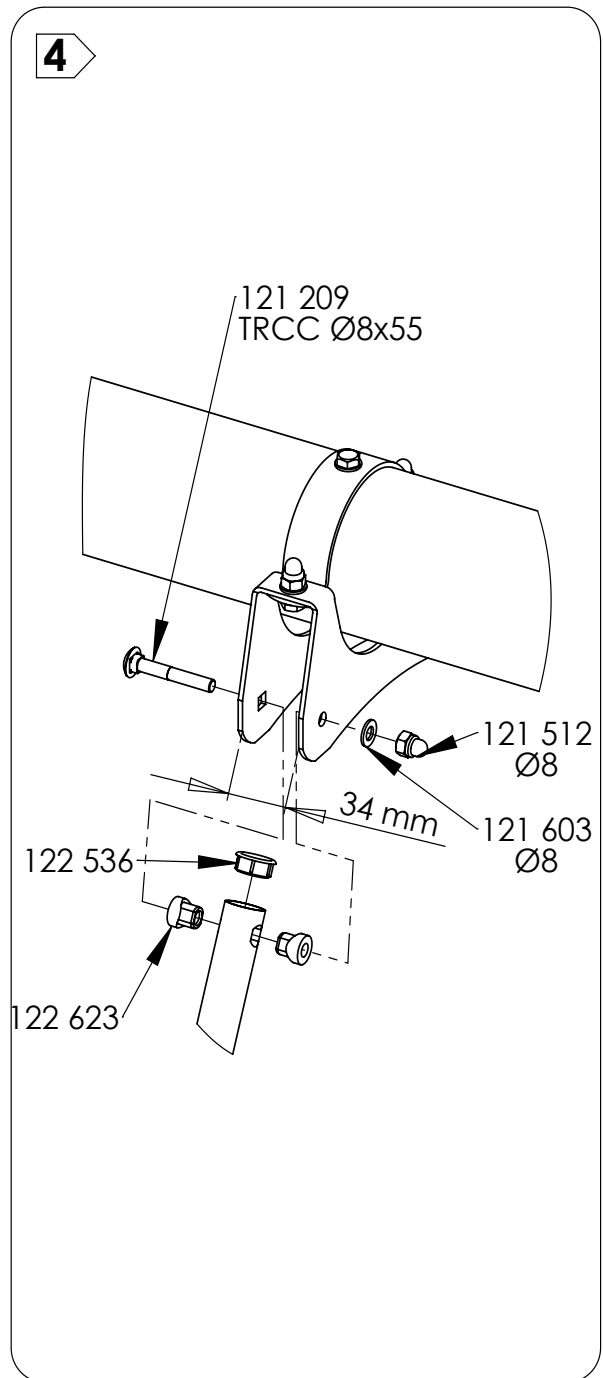
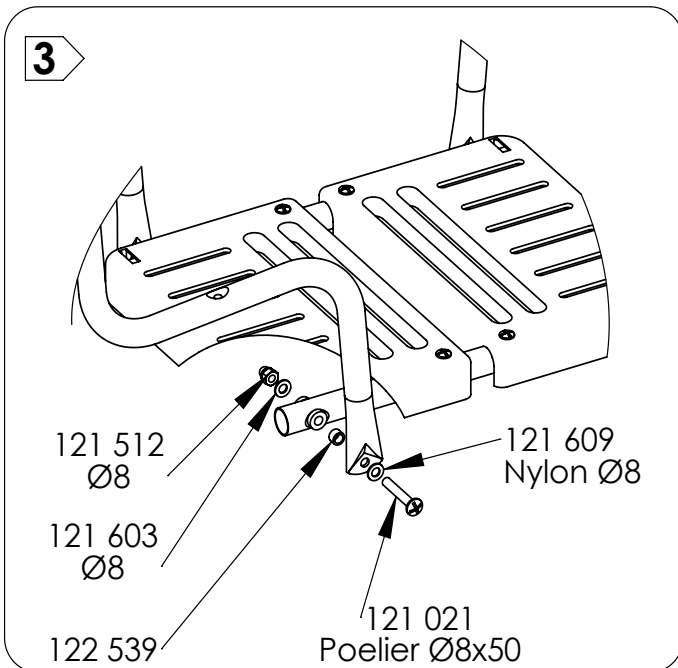
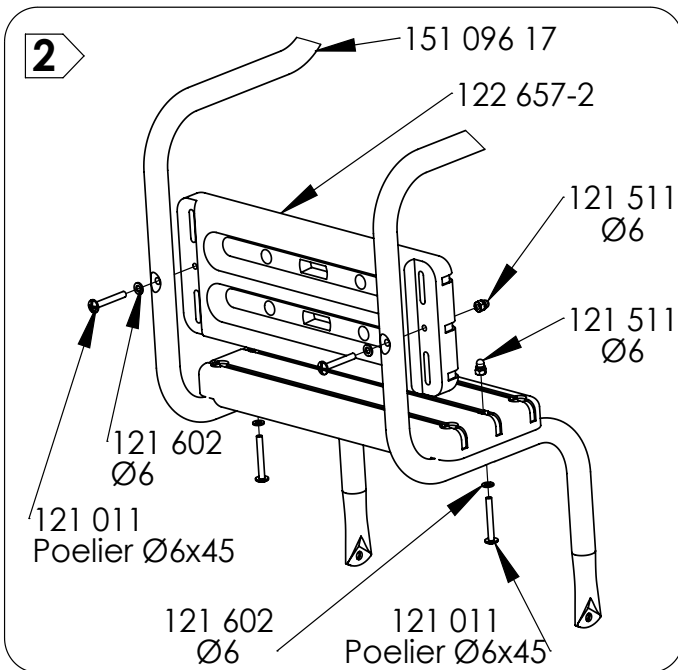
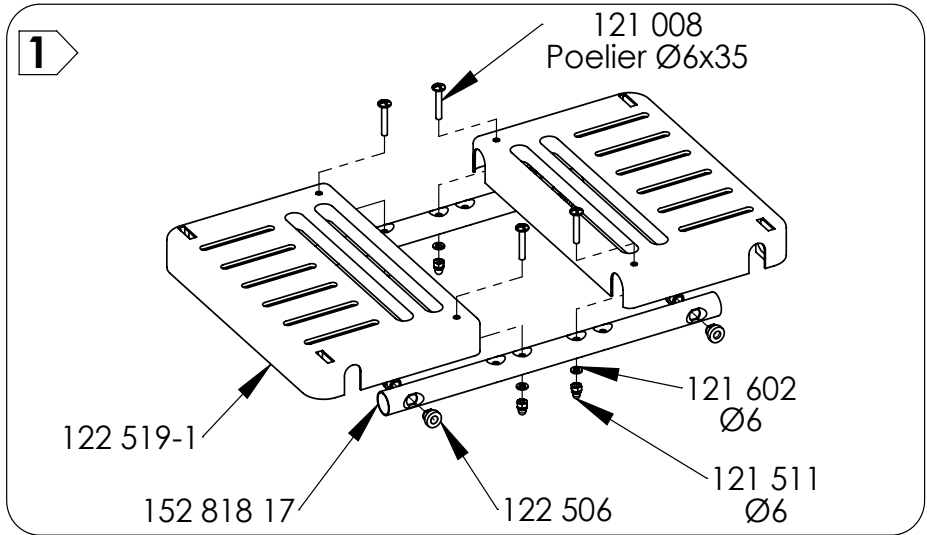
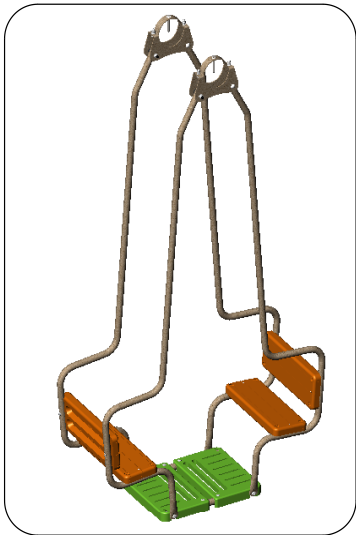

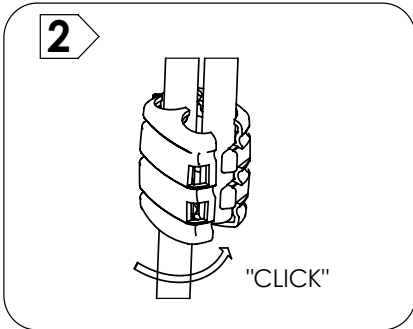

1

Ø	(A)	(B)	(C)	(D)
80	122 037	121 617	121 617	121 509
100	122 035		121 616	121 530

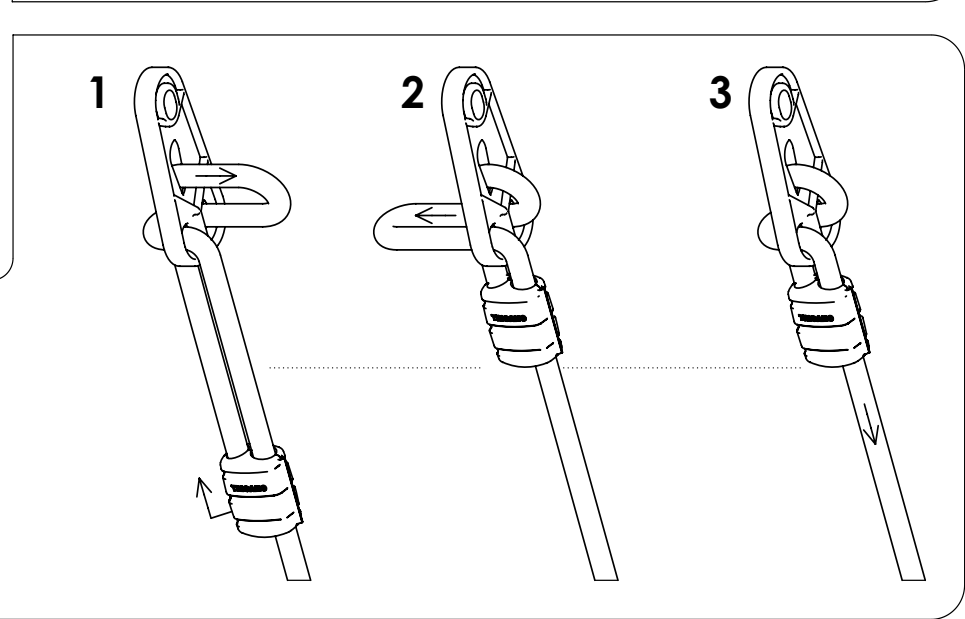
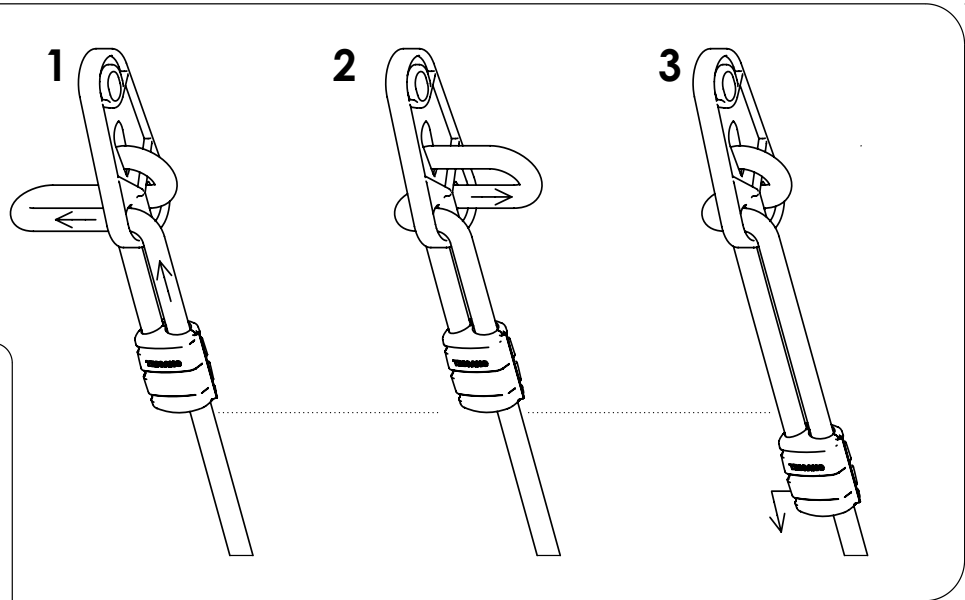
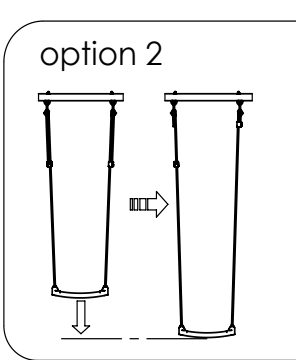
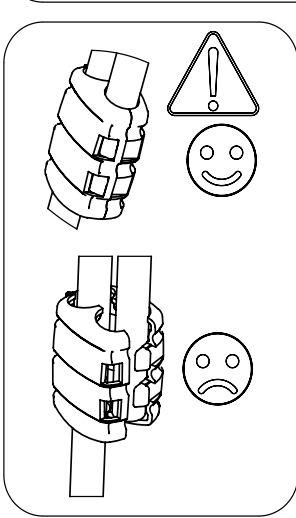
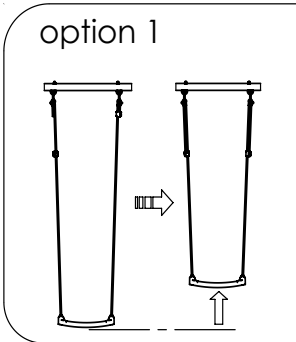

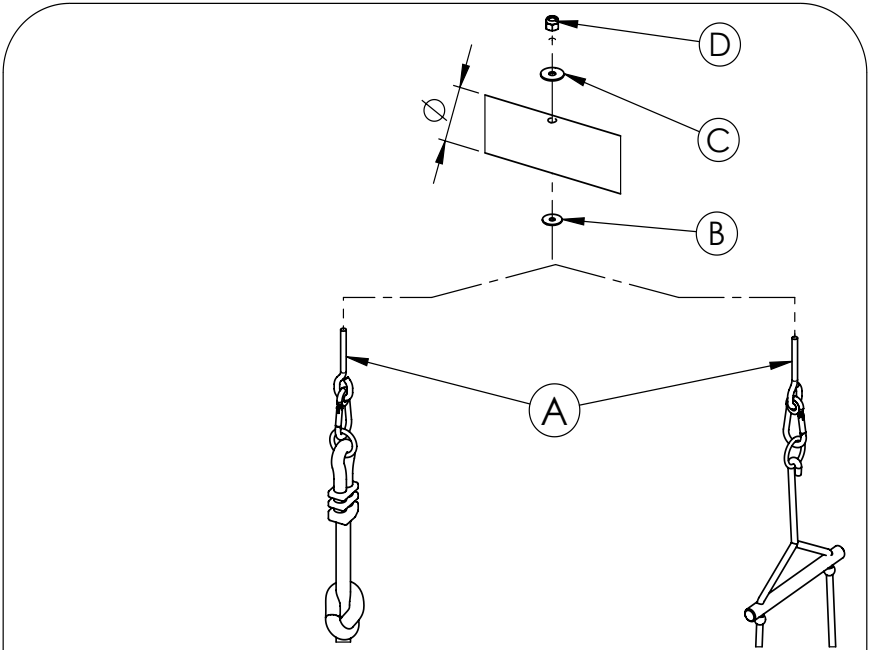
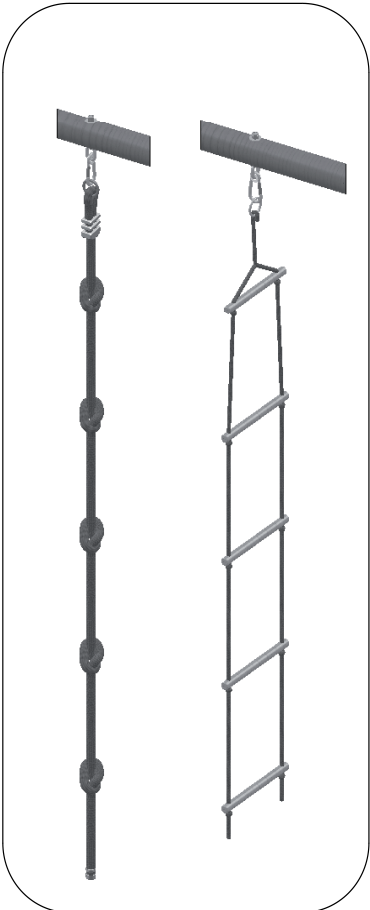
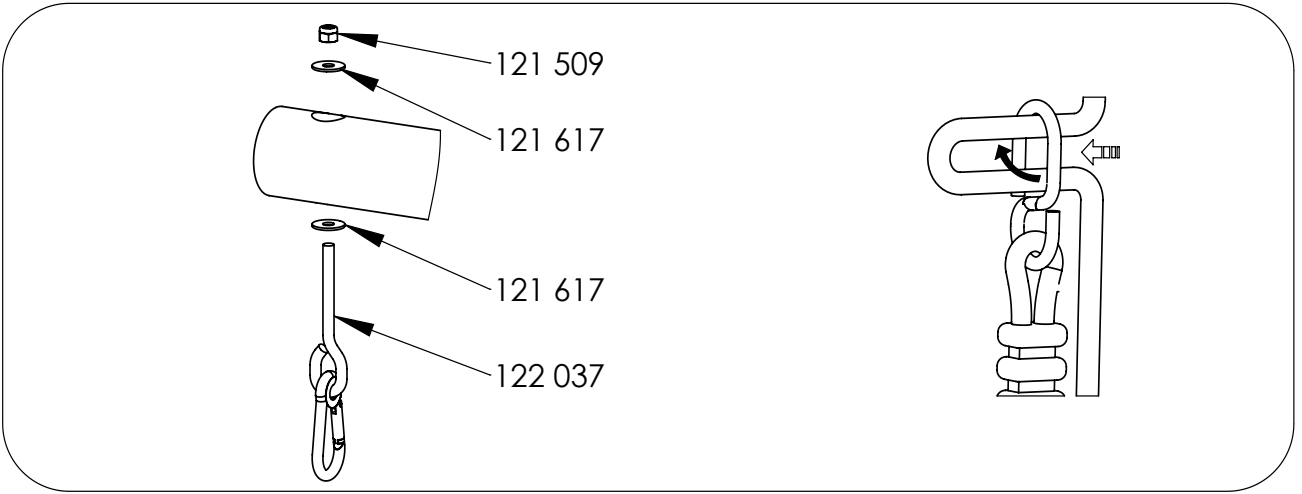
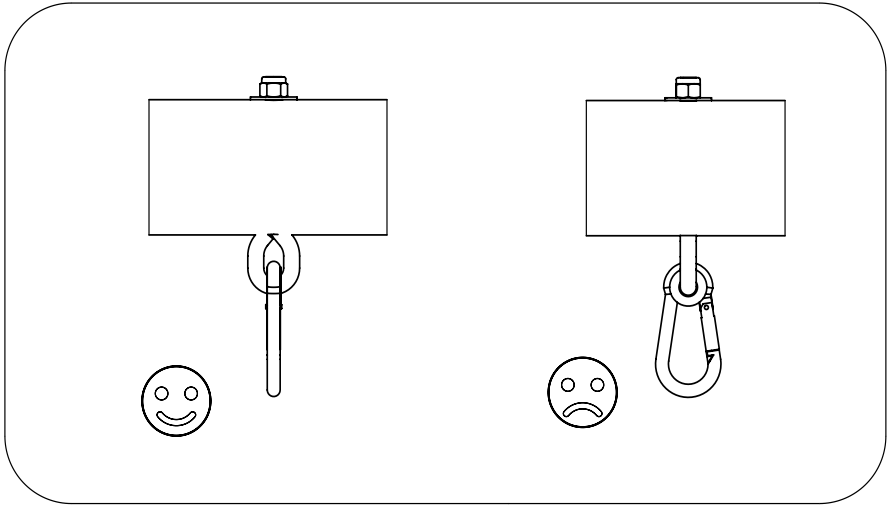

Ø	(A)	(B)	(C)	(D)
80	122 037	121 617	121 617	121 509
100	122 035		121 616	121 530

