

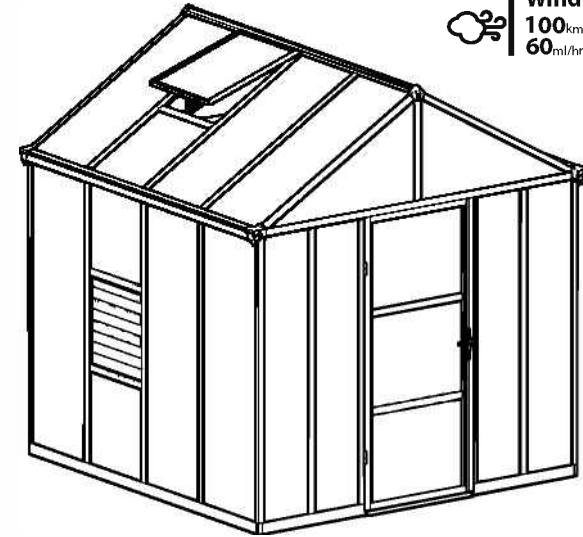

 **Snow Load**  
100kg/m<sup>2</sup>  
20lbs/ft<sup>2</sup>

 **Wind Resistant**  
100km/hr  
60mi/hr



## Assembly Instructions

# Glory™ 8'x8' - Premium Class Greenhouse

Approx. Dim.

244.5L x 244.5W x 268.5Hcm / 96.3"L x 96.3"W x 105.7"H

## 4' Extension Module

119.5L x 244.5W x 268.5Hcm / 47"L x 96.3"W x 105.7"H

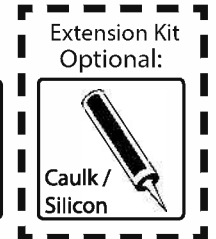
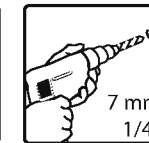
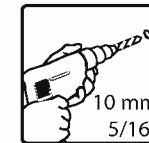
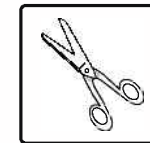
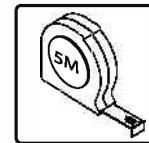
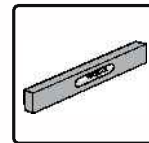
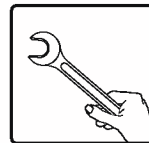
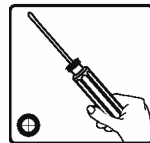
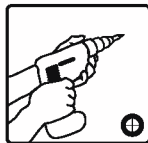

### After Sale Service

Email: [customer.service@palram.com](mailto:customer.service@palram.com)

USA 877-627-8476  
Canada 1 800-866-5749

England 01302-380775  
Germany 0180-522-8778

France 0169-791-094  
International +972 4-848-6942

[www.palramapplications.com](http://www.palramapplications.com)

**IMPORTANT**

Please read these instructions carefully before you start to assemble this greenhouse.  
Keep these instructions in a safe place for future reference.

**» Customer Service**

For assistance with assembly or for replacement parts – please log onto our website or call our service line (number is on the title page).

Additional information can be found at our website: [www.palramapplications.com](http://www.palramapplications.com)

**» Safety Advice**

- It is of utmost importance to assemble all of the parts according to the directions. Do not skip any step.
- We strongly recommend using work gloves during panels' sliding.
- Always wear shoes and safety goggles when working with extruded aluminium.
- If using a step ladder or power tools make sure that you follow the manufacturer's safety advice.
- Do not touch overhead power cables with the aluminium profiles.
- Do not attempt to assemble the greenhouse in windy or wet conditions.
- Dispose of all plastic bags. Keep them out of reach of small children.
- Keep children away from the assembly area.
- Do not lean against or push the greenhouse during construction.
- Do not position your greenhouse in an area exposed to excessive winds.
- Do not attempt to assemble this greenhouse if you are tired, have taken drugs or alcohol or if you are prone to dizzy spells.
- Hot items such as recently used grills, blowtorches etc. must not be stored in the greenhouse. Make sure there are no hidden pipes or cables in the ground before inserting the pegs.
- This product is designed to be used as a greenhouse only.
- **Note:** You should anchor the greenhouse directly to a solid foundation; Make sure that there are no obstructions between the assembly area and the final position.

**» Care & Maintenance**

- When your greenhouse needs to be cleaned, use a mild detergent solution and rinse with cold clean water.
- DO NOT use acetone, abrasive cleaners or other special detergents to clean the clear panels.

**» Tools & Equipment**

- Work gloves
- Phillips head screwdriver
- Adjustable Spanner / Wrench
- Leveler
- Tape measure
- Step ladder
- Scissors
- Electric screwdriver ( 10mm, 7mm, Phillips)
- Lubricant (Optional)
- T001 - Special tool for Screws 411 and nuts 412

**» Before Assembly**

- Selecting a site:
  - The greenhouse must be positioned and fixed on a flat level surface.
  - Choose a sunny position away from overhanging trees.
- We strongly recommend this greenhouse to be secured directly to a solid concrete foundation.
- This is a multi-part assembly best achieved by two people. Allow at least half a day for the assembly process.
- Take all components & parts out of the packages. Sort the parts and check against the content parts list.  
Parts should be laid out close at hand. Keep all small parts (screws etc.) in a bowl so they do not get lost.
- Please note multi-sided profiles are used in this greenhouse. As a result some holes in the profiles are not used during assembly.
- Please review entire instructions before starting. Carry out the assembly steps in exact order.
- Prior to fitting the Automatic Vent Opener, the power-tube has to be cooled by placing it in a refrigerator for approximately 30 minutes.
- The drawings in this manual are designed for 8' x 8' greenhouse + 4' Extension Kit. Please note that content list refers only for 8x8 greenhouse.

**Note:** all the extension module steps are marked with a dashed outline, should be performed during th greenhouse assembly process.

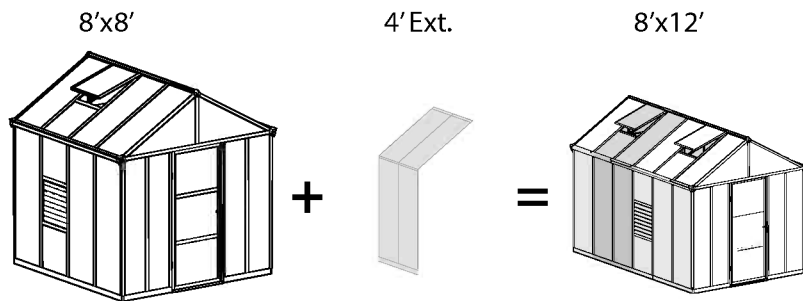

Model	Base Length	No. of Packages
Glory Standard (8' x 8')	244.5 cm / 96.3"	2
Glory + 4' Ext. (8' x 12')	364 cm / 143.3"	3
Glory + 4' Ext. x2 (8' x 16')	483.5 cm / 190.4"	4
Glory + 4' Ext. x3 (8' x 20')	603 cm / 237.4"	5

### » During Assembly

- You may use Silicon lubricant spray in order to help you slide the panels into the profiles.
- Do not spray the Polycarbonate panels.
- Use a rubber mallet if necessary.
- All panels with the stamped words THIS SIDE OUT must be facing out to create full UV protection. Remove plastic sticker as panels are locked in place.
- The Auto Vent Opener has a separate assembly instruction in its own package.



During assembly you will encounter the information icon, please refer to the relevant assembly step for additional comments and assistance.



This icon indicates that the installer should be inside the product.



This icon indicates that the installer should be outside the product.

**Step 9:** Please make sure the screw connection is made exactly as illustrated.

A - Connect the screw in the left hole.

B - Connect the screw in the right hole.

**Step 10:** Peel the film covering the panel. Make sure you install it with the UV protected side out.

**Step 20:** Part **7943** (Side Louver Window) can be located only on one of the two central panels.

\* If you assemble the greenhouse with an extension module, the window can be placed on all panels, except for the last two end panels.

\* **Note:** The selected placing will affect the next assembly steps.

**Step 25:** Please seal panels 7903+7904 (on both sides) with sealing tape **#8293** located in the package.

**Step 26:** It is highly recommended to paste the sealing tape at the bottom edge of panels **7903 + 7904** is order to prevent moisture seepage.

**Step 32:** Roof window can be located only on one of the two central roof panels.

\* If you assemble the greenhouse with an extension module, the roof windows must be placed on panels only as specified in the manual.

\* **Note:** The selected placing will affect the next assembly steps.

**Step 37:** Please tighten screws from inside the greenhouse. In addition, please tighten the remaining loose screws.

**Step 42:** As mentioned at the 'Before Assembly' section, prior to fitting the **Automatic Vent Opener**, the power-tube has to be cooled by placing it in a refrigerator for approximately 30 minutes.

**Step 51:** Door can be installed as a left hand door or right hand door as per your decision. These instructions show a right hand door assembly. Please determine door opening direction. This decision will affect the next assembly steps.

**Step 53:** Please adjust the hinges height in accordance with the upper post and lower ramp of the door aperture, as specified in **Level C**.

**Step 57:** Threading parts **7888** exactly as specified in **Level C**, is very important in order to create good drainage.

**Step 61:** Anchor the shed on to a solid surface such as concrete or asphalt, use suitable screws and plugs. (Screws and plugs are not supplied).



### Important Recommendations

- **Firmly connect the greenhouse to a level surface immediately after completion of the assembly.**
- **Anchoring this product to the ground is essential to its stability and rigidity. It is required to complete this stage in order for your warranty to be valid.**
- **Tighten all screws once assembly is completed.**
- **Anchoring this product to the ground is essential to its stability and rigidity. It is required to complete this stage in order for your warranty to be valid.**

- Screws 411 and nuts 412 are used throughout the assembly process.
- Screws 411 are to be assembled from the outside and nuts 412 from the inside of the greenhouse.
- If not specified otherwise, do not fasten screws and nuts (411 & 412) for more than 2-3 turns. Do not tighten them until completion of the panels' assembly. These 2 icons indicate if screw's tightening is required or not.
- However, in some steps, temporary tightening of a few screws may be needed to prevent a profile from sliding out.

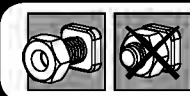

412



411



**IMPORTANT !**

Veuillez lire attentivement ces instructions avant de commencer à monter votre serre. Conservez ces instructions en lieu sûr pour toute consultation ultérieure.

## » Service clientèle

Pour toute assistance concernant le montage de la serre ou ses pièces de rechange – veuillez consulter notre site Internet ou appeler notre service technique (dont le numéro de téléphone figure sur la couverture de la brochure). Pour en savoir plus,

n'hésitez pas à visiter notre site Internet : [www.palamapplications.com](http://www.palamapplications.com)

## » Consignes de sécurité

- Très important ! Veuillez suivre scrupuleusement les instructions de cette brochure et réaliser les étapes dans l'ordre énoncé.
- Nous recommandons vivement le port de gants de protection pendant le montage.
- Portez toujours des chaussures de travail et des lunettes de protection lorsque vous travaillez des pièces en aluminium extrudé.
- Lors de l'utilisation d'une échelle ou d'outils électriques, assurez-vous de bien suivre les consignes de sécurité du fabricant.
- Veillez à ne pas toucher de câbles aériens avec les profilés en aluminium.
- N'essayez pas de monter la serre s'il y a du vent ou s'il fait humide.
- Jetez tous les sacs en plastique en appliquant les règles de sécurité et maintenez-les hors de portée des jeunes enfants.
- Eloignez les enfants de la zone d'assemblage.
- Ne vous appuyez pas contre la serre et ne la poussez pas pendant le montage.
- Ne positionnez pas la serre dans un endroit trop exposé au vent.
- N'essayez pas de monter la serre si vous êtes fatigué, si vous êtes sous l'effet de drogues, de médicaments ou d'alcool ou encore si vous êtes sujet aux vertiges.
- Les objets chauds tels qu'un barbecue, un chalumeau ou autre article ayant été récemment utilisés, ne doivent pas être rangés dans la serre.
- Avant de planter les piquets, assurez-vous qu'aucun tuyau ni câble n'est enterré à l'endroit sélectionné pour l'installation.
- Ce produit est conçu pour servir de serre exclusivement.
- **Remarque:** Vous devez ancrer la serre de jardin directement à une fondation solide ; assurez-vous qu'il n'y a pas d'obstacles entre la zone de montage et la position finale.

## » Entretien &amp; Maintenance

- Pour nettoyer votre serre, utilisez une solution détergente douce et rincez à l'eau claire et froide.
- NE PAS utiliser d'acétone ni de produits nettoyants ou autres détergents spéciaux pour nettoyer les panneaux clairs.

## » Tools &amp; Equipment

- Gants de travail
- Tournevis cruciforme
- Clé à molette / Clé
- Niveleur
- Ruban à mesurer
- Escabeau
- Ciseaux
- Tournevis électrique (10 mm, 7 mm, Cruciforme)
- Lubrifiant (Facultatif)
- T001 - Outil spécial pour vis 411 et écrous 412



## » Avant le montage

- Choisir un endroit :
  - La serre doit être positionnée et fixée sur une surface plane et horizontale.
  - Choisissez un endroit ensoleillé loin des arbres en saillie.
- Nous vous recommandons fortement de sécuriser cette serre directement à une fondation en béton solide. Utilisez les trous pré-perçés dans la base métallique au moment de la faire.
- Il s'agit d'un assemblage multi parties qu'il vaut mieux réaliser à deux. Comptez au moins une demi journée pour le processus de montage.
- Retirez tous les composants des paquets. Triez les éléments et vérifiez la liste. Les éléments doivent se trouver à portée de main.
 

Gardez tous les petits éléments (vis etc.) dans un bol pour ne pas les perdre.
- Veuillez noter que des coupes multi faces sont utilisées dans cette serre. C'est pourquoi certains trous dans les coupes ne sont pas utilisés pendant le montage.
- Veuillez vérifier toutes les instructions avant de commencer. Procédez aux étapes de montage dans l'ordre exact.
- Avant d'installer le mécanisme d'ouverture automatique, le tube de puissance doit être refroidi en le plaçant dans un réfrigérateur pendant environ 30 minutes.
- Les schémas de ce manuel sont conçus pour un serre de jardin 8'x 8' + Kit d'extension 4'. Veuillez noter que la liste de contenu se réfère uniquement aux serres de jardin 8'x8'.

**Remarque :** Toutes les étapes de module d'extension sont marquées avec un contour en pointillés dans l'intégralité du processus d'assemblage du serre de jardin.

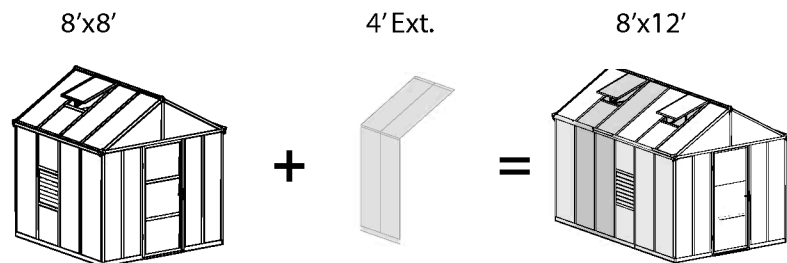

Modèle	Longueur de la base	Nombre de packs
Glory Standard (8' x 8')	244.5 cm / 96.3"	2
Glory + 4' Ext. (8' x 12')	364 cm / 143.3"	3
Glory + 4' Ext. x2 (8' x 16')	483.5 cm / 190.4"	4
Glory + 4' Ext. x3 (8' x 20')	603 cm / 237.4"	5

### » Durant l'assemblage

- Vous pouvez utiliser un spray de silicone lubrifiant afin de vous aider à glisser les panneaux dans les profils.
- Ne pulvérisez pas les panneaux en polycarbonate.
- Utilisez un maillet en caoutchouc si nécessaire.
- Tous les panneaux estampillés "CE CÔTÉ VERS L'EXTÉRIEUR" doivent être orientés vers l'extérieur pour assurer une protection UV intégrale. Retirez les stickers en plastique alors que les panneaux sont verrouillés en place.
- Le mécanisme d'ouverture mécanique vient avec des instructions de montage séparées dans son propre emballage.



Pendant le montage, vous verrez l'icône d'information, veuillez-vous référer à la phase de montage correspondante pendant des commentaires et une assistance supplémentaires.



Cette icône indique que l'installateur doit être à l'intérieur du produit



Cette icône indique que l'installateur doit être en dehors du produit.

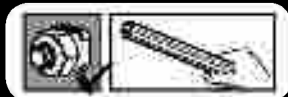
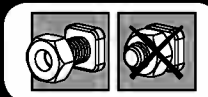

**Étape 9 :** Veuillez vérifier que l'insertion des vis est effectuée exactement comme illustré.

**A** - Insérez la vis dans le trou de gauche. **B** - Insérez la vis dans le trou de droite.

**Étape 10 :** Assurez-vous que cette face est bien tournée vers le haut lors de l'installation, car c'est la seule à être enduite d'un vernis anti-UVs.

**Étape 20 :** La pièce **7943** (Fenêtre persienne du côté) peut être placée seulement sur un des deux panneaux centraux.

\* Pour assembler le serre de jardin avec un module d'extension, la fenêtre peut être placée sur les panneaux, à l'exception des deux derniers panneaux d'extrémité.

\* **Remarque :** L'emplacement sélectionné aura des conséquences sur les prochaines étapes de montage.

**Étape 25 :** Veuillez sceller les panneaux **7903+7904** (sur les deux côtés) avec la bande d'étanchéité **#8293** contenue dans le paquet.

**Étape 26 :** il est fortement conseillé de coller le ruban d'étanchéité sur les bords inférieurs des panneaux **7903 + 7904** afin d'éviter l'infiltration d'humidité.

**Étape 32 :** La fenêtre du toit peut être placée uniquement sur l'un des deux panneaux centraux du toit.

\* Si vous assemblez le serre de jardin avec un module d'extension, les fenêtres de toit doivent être placées sur des panneaux seulement comme spécifié dans le manuel.

\* **Remarque :** L'emplacement sélectionné aura des conséquences sur les prochaines étapes de montage.

**Étape 37 :** Veuillez serrer les vis de l'intérieur du serre de jardin. En outre, veuillez serrer les vis desserrées restantes.

**Étape 42 :** Comme mentionné dans la section « **Avant d'assembler** », avant de poser le **mécanisme d'ouverture automatique**, le tube de puissance doit être refroidi en le plaçant dans un réfrigérateur pendant environ 30 minutes.

**Étape 51 :** La porte peut être installée et ouverte à gauche ou à droite selon votre préférence. Ces instructions montrent l'assemblage d'une porte à droite. Veuillez déterminer le sens d'ouverture de la porte. Cette décision aura des conséquences sur les prochaines étapes de montage.

**Étape 53 :** Veuillez ajuster la hauteur des charnières en conformité avec le poste supérieur et la rampe inférieure de l'ouverture de la porte, comme spécifié dans le **niveau C**.

**Étape 57 :** Threading des pièces **7888** exactement comme spécifié dans le **niveau C** est très important pour créer un bon drainage.

**Étape 61 :** Ancrez l'abri sur une surface solide comme du béton ou de l'asphalte, utilisez des vis et des chevilles adaptées. (Les vis et les chevilles ne sont pas fournies).



### Recommandations Importantes

- **Connectez le serre de jardin fermement à une surface nivelée après l'achèvement de l'assemblage.**
- **Cette étape d'ancrage du produit au sol est essentielle à sa stabilité et à sa rigidité, elle est de plus nécessaire pour assurer la validité de votre garantie.**
- **Serrez toutes les vis une fois l'assemblage terminé.**
- **Veuillez noter : cette étape d'ancrage du produit au sol est essentielle à sa stabilité et à sa rigidité, elle est de plus nécessaire pour assurer la validité de votre garantie.**

Les vis 411 et écrous 412 servent tout au long de la procédure.

- Les vis 411 se placent à l'extérieur et les écrous 412 à l'intérieur de la serre.
- Ne serrez les vis et écrous (411 & 412) que de 2 à 3 tours, pas plus. Ne les serrez pas tant que l'assemblage n'est pas complètement terminé, sauf indication contraire.
- Cependant, la réalisation de certaines étapes peut nécessiter le serrage provisoire de quelques vis pour empêcher un profilé de tomber en attendant qu'il soit entièrement intégré à l'ensemble de la structure dans les étapes suivantes.

**IMPORTANTE**

Por favor, lea estas instrucciones cuidadosamente antes de empezar a montar este invernadero. Mantenga estas instrucciones en un lugar seguro para referencia futura.

**» Servicio de Ayuda al Cliente**

Para obtener ayuda con el montaje o para las piezas de recambio - por favor entre a nuestro sitio web o llame a nuestra línea de servicio (el número está en la página de título).

Información adicional se puede encontrar en nuestro sitio web:  
www.palramapplications.com

**» Consejo de Seguridad**

- Es de suma importancia montar todas las partes de acuerdo con las instrucciones. No se salte ningún paso.
- Recomendamos firmemente el uso de guantes de trabajo durante el montaje.
- Use siempre zapatos y gafas de seguridad al trabajar con aluminio extruido.
- Al usar una escalera plegable o herramientas eléctricas asegúrese de que sigue las instrucciones de seguridad de los fabricantes.
- No toque los cables eléctricos aéreos con los perfiles de aluminio.
- No intente montar el invernadero en días de viento o días con humedad.
- Disponga todas las bolsas plásticas en lugar seguro - guárdelas fuera del alcance de niños.
- Mantenga a los niños fuera del área de montaje.
- No se apoye ni empuje el invernadero durante la construcción.
- No coloque su invernadero en un área expuesta al viento excesivo.
- No intente montar este invernadero si usted está cansado, ha tomado drogas o alcohol o si usted es propenso a ataques de mareo.
- Artículos calientes recientemente usados tales como parrillas, sopletes etc. no deben ser almacenados en el invernadero. Asegúrese de que no haya ninguna tubería o cables ocultos en la tierra antes de insertar las clavijas.
- Este producto es designado a ser usado solamente como invernadero.
- **Nota:** debe anclar el invernadero directamente a un cimiento sólido. Asegúrese de que no haya obstrucciones entre el área de montaje y la posición final.

**» Cuidados & Mantenimiento**

- Cuando precise limpiar su invernadero, use una solución de detergente suave y aclare con agua limpia fría.
- NO use acetona, limpiadores abrasivos u otros detergentes especiales para limpiar los paneles transparentes.

**» Herramientas & Equipos**

- Guantes de trabajo
- Destornillador de estrella
- Llave inglesa ajustable/Llave inglesa
- Nivelador
- Cinta métrica
- Escalera de peldaños
- Tijeras
- Destornillador eléctrico ( 10 mm, 7 mm, Phillips -estrella-)
- Lubricante (opcional)
- T001: herramienta especial para tornillos 411 y tuercas 412

**» Antes del Montaje**

- Seleccionar un lugar:
  - El invernadero debe colocarse y fijarse en una superficie plana y nivelada.
  - escoja una ubicación soleada y apartada de árboles que la cubran.
- Recomendamos encarecidamente que el invernadero se fije directamente sobre cimientos de cemento sólido. Para hacer esto, utilice los agujeros previamente taladrados en la base de metal.
- Este montaje consta de varias partes y sería óptimo que lo realizasen dos personas. El proceso de montaje llevará alrededor de medio día.
- Extraiga todas las piezas de componentes de sus embalajes. Ordene las piezas y compruebe que están todas usando la lista de contenidos. Las piezas deberían colocarse cerca y tenerlas a mano. Ponga las piezas pequeñas (p. ej. tornillos) en un bol para no perderlas.
- Por favor, tenga en cuenta que este invernadero incluye perfiles con múltiples superficies. Como resultado, algunos de los agujeros de los perfiles no se utilizan durante el montaje.
- Por favor, revise todas las instrucciones antes de empezar. Siga los pasos del montaje en el orden exacto.
- Antes de encajar la apertura automática de ventilación, tiene que enfriarse el tubo de corriente; para ello, colóquelo unos 30 minutos en un refrigerador.
- Los dibujos de este manual están diseñados para el invernadero de 2,43 m x 2,43 m (8' x 8') + el kit de ampliación de 1,20 m (4'). Tenga en cuenta, por favor, que la lista de contenido se refiere solo al invernadero de 2,43 m x 2,43 m.

**Note:** Todos los pasos del modulo de ampliación están marcados íntegramente con un contorno de trazos en el proceso de montaje del invernadero.

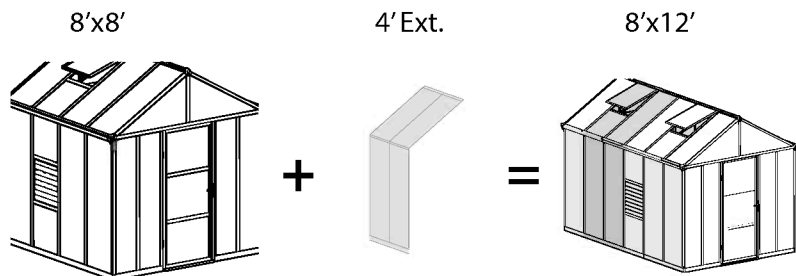

Modelo	Longitud de la base	N.º de paquetes
Glory Estándar (8' x 8')	244.5 cm / 96.3"	2
Glory + 4' Ext. (8' x 12')	364 cm / 143.3"	3
Glory + 4' Ext. x2 (8' x 16')	483.5 cm / 190.4"	4
Glory + 4' Ext. x3 (8' x 20')	603 cm / 237.4"	5

## » Durante el montaje

- Puede utilizar espray lubricante de silicona para facilitar el deslizamiento de los paneles en los contornos.
- No ponga espray en los paneles de policarbonato.
- Use un martillo de goma si hiciere falta.
- Todos los paneles que tengan estampado LADO EXTERIOR (THIS SIDE OUT) deben mirar hacia fuera para ofrecer una protección UV completa. Quite la pegatina de plástico una vez los paneles se enganchen en su sitio.
- La apertura de ventilación automática tiene las instrucciones de montaje aparte, en su propio paquete.



Cuando encuentre el ícono de información, por favor lea con cuidado dicho paso con comentarios y asistencia adicionales.



Este ícono indica que el instalador debe estar dentro del producto.



Este ícono indica que el instalador debe estar fuera del producto.

**Paso 9:** Por favor, asegúrese de que la conexión del tornillo se hace exactamente como se muestra.

**A** – Conecte el tornillo en el orificio izquierdo.

**B** - Conecte el tornillo en el orificio derecho.

**Paso 10:** Pele la película que cubre el panel. Asegúrese de instalarla con el lado con protección UV hacia afuera.

**Paso 20:** pieza **7943** (ventana lateral con lamas) solo puede colocarse en uno de los dos paneles centrales.

\* Si monta el invernadero con un módulo de ampliación, la ventana se puede colocar en todos los paneles, excepto los dos últimos paneles del final.

\* **Nota:** la colocación elegida afectará a los pasos de montaje siguientes.

**Paso 25:** por favor, selle los paneles 7903+7904 (por ambos lados) con la cinta de sellar #8293 que se encuentra en el paquete.

**Paso 26:** se recomienda encarecidamente que se coloque la cinta selladora en el extremo inferior de los paneles **7903 + 7904** con el fin de evitar filtraciones de humedad.

**Paso 32:** la ventana del tejado puede localizarse en uno de los dos paneles centrales del tejado.

\* Si monta el invernadero con un módulo de ampliación, las ventanas del tejado deben colocarse sobre paneles solo según se especifica en el manual.

\* **Nota:** la colocación elegida afectará a los pasos de montaje siguientes.

**Paso 37:** por favor, apriete los tornillos desde el interior del invernadero. Además apriete, por favor, los tornillos que estén flojos.

**Paso 42:** Como se ha mencionado en la sección de "Antes del montaje", antes de encajar la **apertura de ventilación automática**, se debe enfriar el tubo de la corriente durante unos 30 minutos en el refrigerador.

**Paso 51:** La puerta se puede instalar ya sea al lado izquierdo o al derecho, es su decisión. En estas instrucciones se ve el montaje de la puerta en el lado derecho. Por favor, determine la dirección de apertura de la puerta. Esta decisión afectará a los pasos del montaje siguientes.

**Paso 53:** Por favor, ajuste la altura de los goznes de acuerdo al poste superior y la rampa inferior de la apertura de la puerta, como se especifica en el **nivel C**.

**Paso 57:** Ensartar las piezas **7888** exactamente como se especifica en el **nivel C**; es muy importante, para así crear un buen desagüe.

**Paso 61:** Ancle el cobertizo a una superficie sólida como hormigón o asfalto, utilice tornillos y tapones adecuados. (No se su ministran los tornillos y tapones).

\***Por favor, tenga en cuenta:** Anclar este producto al suelo es esencial para su estabilidad y rigidez. Es necesario completar esta fase para que su garantía sea válida.



### Recomendaciones importantes

- **Conecte firmemente el invernadero a una superficie nivelada inmediatamente después de terminar el montaje.**
- **Por favor, tenga en cuenta: Anclar este producto al suelo es esencial para su estabilidad y rigidez. Es necesario completar esta fase para que su garantía sea válida.**
- **Apriete todos los tornillos una vez esté completado el montaje.**
- **Por favor, tenga en cuenta: Anclar este producto al suelo es esencial para su estabilidad y rigidez. Es necesario completar esta fase para que su garantía sea válida.**

- **Los tornillos 411 y las tuercas 412 son usados durante todo el proceso de montaje.**
- Los tornillos 411 deben ser montados desde el exterior y las tuercas 412 desde el interior del invernadero.
- No apriete los tornillos y tuercas (411 y 412) más de 2-3 vueltas. No los apriete hasta terminar el montaje de los paneles, a menos que orientado de otra manera.
- Sin embargo, en algún paso puede ser necesario apretar de forma temporal algunos tornillos para evitar que se caiga un perfil.

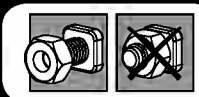

**WICHTIG**

Bitte lesen Sie diese Anweisungen sorgfältig durch, bevor Sie mit dem Aufbau des Gewächshauses beginnen.

Heben Sie diese Anweisungen an einem sicheren Ort auf, um später auf sie zurückgreifen zu können.

## » Kundendienst

Für Hilfe bei dem Aufbau oder für Ersatzteile – können Sie sich entweder auf unserer Webseite einloggen oder unseren Kundendienst anrufen (die Nummer steht auf der Titelseite).  
www.palamapplications.com

## » Sicherheitshinweise

- Es ist von grösster Wichtigkeit, alle Teile genau gemäss den Anweisungen zusammenzubauen. Lassen Sie keinen Schritt aus.
- Wir empfehlen wärmstens, während des Aufbaus Arbeitshandschuhe zu tragen.
- Tragen Sie immer Schuhe und eine Schutzbrille, wenn Sie mit stranggepresstem Aluminium arbeiten.
- Wenn Sie eine Stufenleiter oder Elektrowerkzeuge benutzen, achten Sie darauf, die Sicherheitshinweise des Herstellers zu befolgen.
- Berühren Sie mit den Aluminiumprofilen keine Oberleitungen.
- Versuchen Sie nicht, das Gewächshaus bei windigem oder regnerischem Wetter zusammenzubauen.
- Entsorgen Sie alle Plastiktüten sicher und bewahren sie ausserhalb der Reichweite von kleinen Kindern auf.
- Halten Sie Kinder vom Aufbaubereich fern.
- Während des Aufbaus sollten Sie sich nicht gegen das Gewächshaus lehnen oder es drücken.
- Bauen Sie Ihr Gewächshaus nicht an Orten mit hoher Windbelastung auf.
- Versuchen Sie nicht, dieses Gewächshaus aufzubauen wenn Sie müde sind, unter dem Einfluss von Drogen oder Alkohol stehen oder zu Schwindelanfällen neigen.
- Heisse Geräte wie kürzlich benutzte Grills, Schneidbrenner usw. dürfen nicht im Gewächshaus gelagert werden. Vergewissern Sie sich vor Einsetzen der Pflöcke, dass sich keine versteckten Rohre oder Kabel im Boden befinden.
- Dieses Produkt ist nur für den Einsatz als Gewächshaus geeignet.
- **Hinweis:** Sie sollten das Gewächshaus direkt in einem stabilen Fundament verankern. Sorgen Sie dafür, dass sich zwischen dem Montage- und dem Aufstellort des Gewächshauses keine Hindernisse befinden.

## » Pflege &amp; Wartung

- Wenn Ihr Gewächshaus gereinigt werden muss, verwenden Sie ein mildes Reinigungsmittel und spülen Sie mit kaltem, sauberem Wasser nach.
- Verwenden Sie zur Reinigung der durchsichtigen Elemente KEIN Aceton und auch keine anderen scheuernden Reinigungsmittel oder andere Spezialreiniger.

## » Tools &amp; Equipment

- Arbeitshandschuhe
- Kreuzschlitz-Schraubendreher
- Rollgabelschlüssel / Schraubenschlüssel
- Wasserwaage
- Maßband
- Stehleiter
- Schere
- Akku-Schraubendreher (10 mm, 7 mm, Kreuzschlitz)
- Schmiermittel (optional)
- T001 – Spezialwerkzeug für Schrauben 411 und Muttern 412



## » Vor dem Zusammenbau

- Einen Aufstellungsort auswählen:
  - Das Gewächshaus muss auf einem flachen Untergrund aufgestellt und befestigt werden.
  - Wählen Sie eine sonnige Position abseits von überhängenden Bäumen.
- Wir empfehlen dringend, dieses Gewächshaus direkt auf einem soliden Betonfundament zu befestigen. Verwenden Sie dabei die vorgebohrten Löcher in der Metallbasis.
- Dieser mehrteilige Bausatz sollte am besten von zwei Personen aufgebaut werden. Nehmen Sie sich für den Zusammenbau mindestens einen halben Tag Zeit.
- Entpacken Sie alle Bauteile. Sortieren Sie die Teile und vergleichen Sie sie mit der Stückliste. Die Teile sollten griffbereit ausgelegt werden.
  - Bewahren Sie alle kleinen Teile (Schrauben usw.) in einer Schüssel, um zu verhindern, dass sie verlorengehen.
- Beachten Sie bitte, dass bei diesem Gewächshaus mehrseitige Profile verwendet werden. Während des Zusammenbaus werden daher einige Löcher in den Profilen nicht verwendet.
- Lesen Sie bitte vor dem Zusammenbau die gesamte Anleitung durch. Befolgen Sie beim Zusammenbau die genaue Reihenfolge.



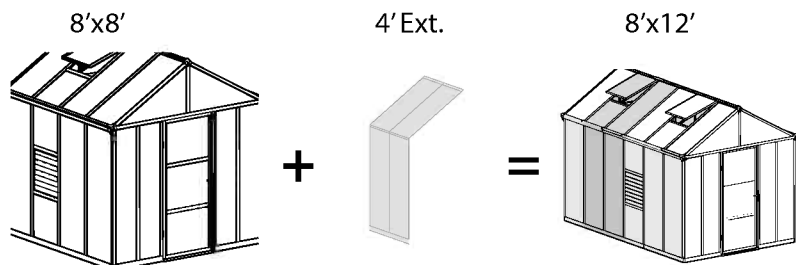

Modell	Basislänge	Packungsanzahl
Glory Standard (8' x 8')	244.5 cm / 96.3"	2
Glory + 4' Ext. (8' x 12')	364 cm / 143.3"	3
Glory + 4' Ext. x2 (8' x 16')	483.5 cm / 190.4"	4
Glory + 4' Ext. x3 (8' x 20')	603 cm / 237.4"	5

### » Während der Montage

- Um das Einführen der einzelnen Platten in die Profile zu vereinfachen, können Sie Silikon-Gleitspray verwenden.
- Besprühen Sie nicht die Polycarbonat-Platten.
- Nehmen Sie – falls nötig – einen Gummihammer zur Hilfe.
- Alle mit den Worten THIS SIDE OUT versehenen Platten müssen nach außen zeigen, damit der volle UV-Schutz garantiert werden kann.
- Entfernen Sie die Aufkleber, sobald die Platten montiert sind.
- Dem automatischen Belüftungsöffner ist eine separate Installationsanleitung beigelegt.



Beim Aufbau wird Ihnen das Informationssymbol begegnen. Für zusätzliche Kommentare und Unterstützung beziehen Sie sich bitte auf die entsprechende Aufbaustufe.



Dieses Symbol zeigt an, dass sich die installierende Person sich im Inneren des Produktes befinden sollte.



Dieses Symbol zeigt an, dass die installierende Person sich außerhalb des Produktes befinden sollte.

**Schritt 9:** Bitte stellen Sie sicher, dass die Schraubverbindung exakt gemäß der Abbildung erfolgt. A – Stecken Sie die Schraube in die linke Öffnung. B – Stecken Sie die Schraube in die rechte Öffnung.

**Schritt 10:** Diese Seite soll nach oben zeigend angebracht werden. Sie ist die Einzige mit einer UV-Schutz Lackierung.

**Schritt 20:** Teil 7943 (seitliches Lüftungsfenster) kann ausschließlich in einer der beiden mittleren Platten montiert werden.

\* Falls Sie das Gewächshaus zusammen mit einem Erweiterungsmodul aufbauen, kann das Fenster – bis auf die beiden Endplatten – auf jeder beliebigen Platte installiert werden.

\* **Hinweis:** Die zur Befestigung gewählte Platte beeinflusst die folgenden Montageschritte.

**Schritt 25:** Versiegeln Sie bitte die Platten 7903 + 7904 (an beiden Seiten) mit dem im Paket befindlichen Dichtband #8293.

**Schritt 26:** Es wird sehr empfohlen das Dichtungsband and das untere Ende der Panels 7903 + 7904 zu kleben, um das Durchsickern von Feuchtigkeit zu verhindern.

**Schritt 32:** Dachfenster kann nur auf einem der beiden mittleren Dachpaneele angeordnet sein.

\* Wenn Sie das Gewächshaus mit einem Erweiterungsmodul montieren, müssen die Dachfenster auf Panels nur, wie im Handbuch angegeben platziert werden.

\* **Hinweis:** Die zur Befestigung gewählte Platte beeinflusst die folgenden Montageschritte.

**Schritt 37:** Ziehen Sie die Schrauben bitte von innen fest. Ziehen Sie außerdem alle verbleibenden losen Schrauben fest.

**Schritt 42:** Wie im Abschnitt „Vor der Montage“ beschrieben, muss der Stromkanal vor der Montage des automatischen Belüftungsöffners zum Abkühlen für ca. 30 Minuten in den Kühlschrank gelegt werden.

**Schritt 51:** Die Tür kann nach Belieben sowohl links- als auch rechtsöffnend installiert werden. In der Anleitung wird die Installation einer linksöffnenden Tür beschrieben. Bitte entscheiden Sie sich für eine Öffnungsrichtung. Von dieser Entscheidung hängen die folgenden Montageschritte ab.

**Schritt 53:** assen Sie die Befestigungshöhe der Scharniere – wie in Teil C beschrieben –entsprechend dem oberen Pfostenteil und der Rampe der Türöffnung an.

**Step 57:** Das Einziehen der Teile 7888 entsprechend den Anweisungen in Teil C ist äußerst wichtig, um einen funktionierenden Abfluss zu gewährleisten.

**Step 61:** Verankern Sie die Hütte auf einem festen Untergrund wie Beton oder Asphalt mittels angemessener Schrauben und Dübeln. (Schrauben und Dübel sind nicht mitgeliefert).



### Wichtige Hinweise

- Befestigen Sie das Gewächshaus sofort nach Fertigstellung der Montage auf einem geraden Untergrund.
- Die Verankerung dieses Produkts im Untergrund ist wesentlich für seine Stabilität und Festigkeit. Sie ist unablässlich, um diesen Arbeitsschritt zu beenden, damit Ihre Garantie gültig bleibt.
- Ziehen Sie alle Schrauben fest, sobald die Montage beendet ist.
- Bitte beachten Sie: Die Verankerung dieses Produkts im Untergrund ist wesentlich für seine Stabilität und Festigkeit. Sie ist unablässlich, um diesen Arbeitsschritt zu beenden, damit Ihre Garantie gültig bleibt.

• In manchen Fällen kann es jedoch nötig sein, einige Schrauben vorübergehend festzuziehen, um das Umfallen eines Profils zu vermeiden. (466)

• Ziehen Sie die Schrauben und Muttern (411 und 466) nicht mit mehr als 2 – 3 Umdrehungen fest. Ziehen Sie sie erst nach Beendigung der Verglasung weiter fest, falls dies nicht ausdrücklich anders festgelegt ist.

• Bei einigen Schritten müssen allerdings eventuell ein paar Schrauben vorübergehend angezogen werden, um zu vermeiden dass ein Profil fällt.

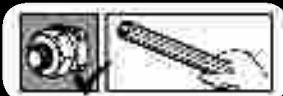

466



411



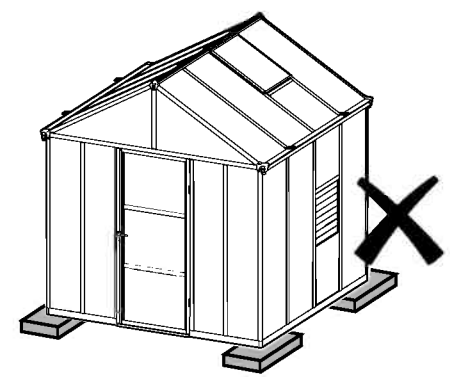
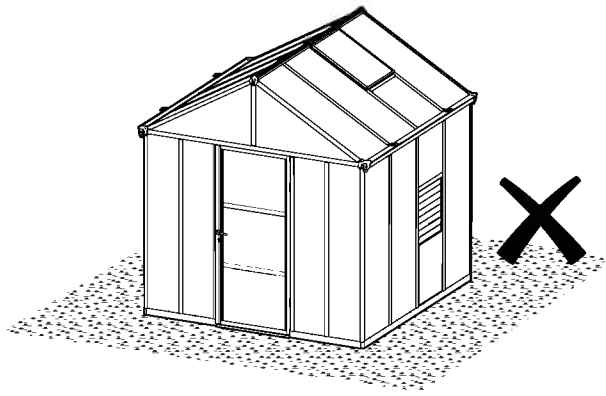
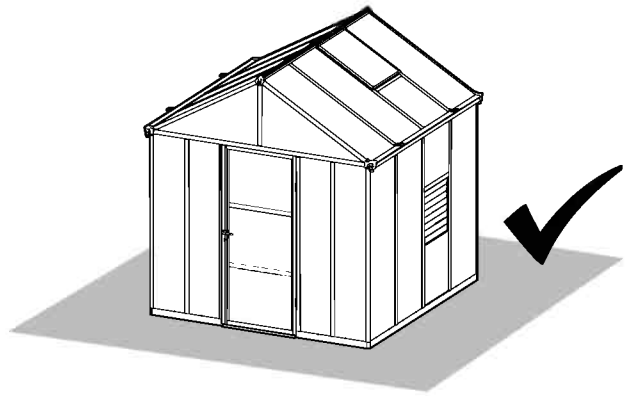



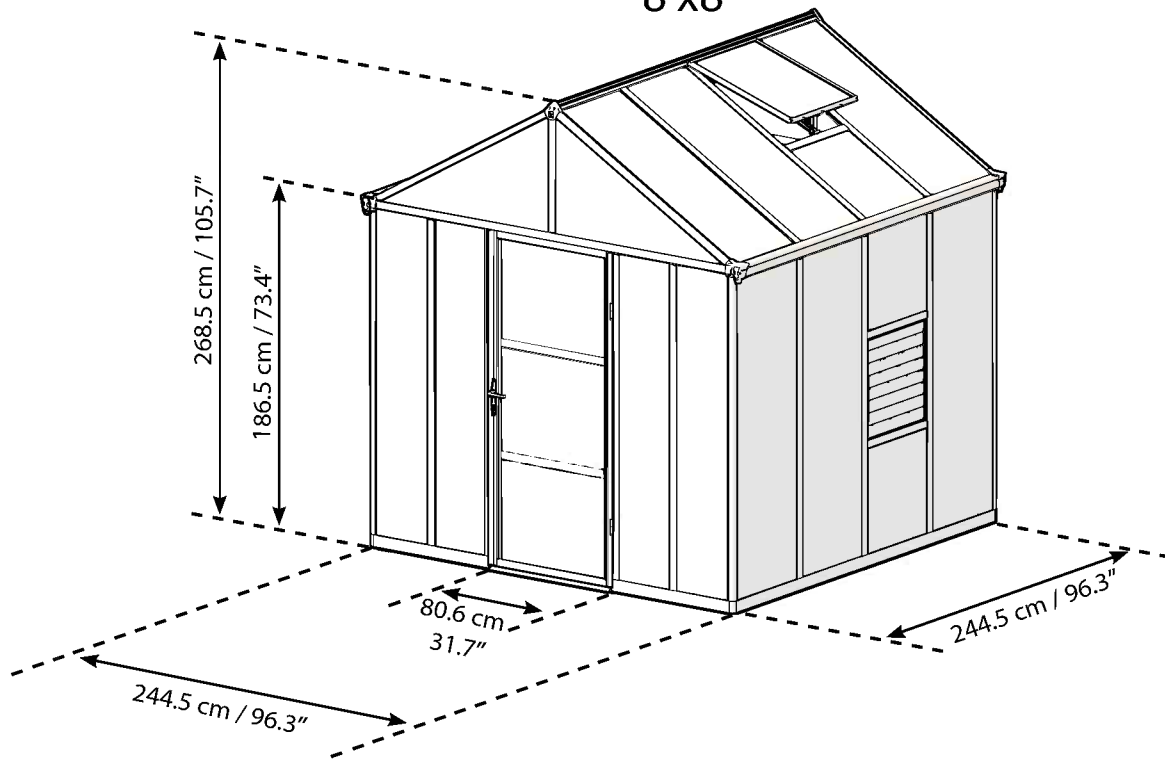



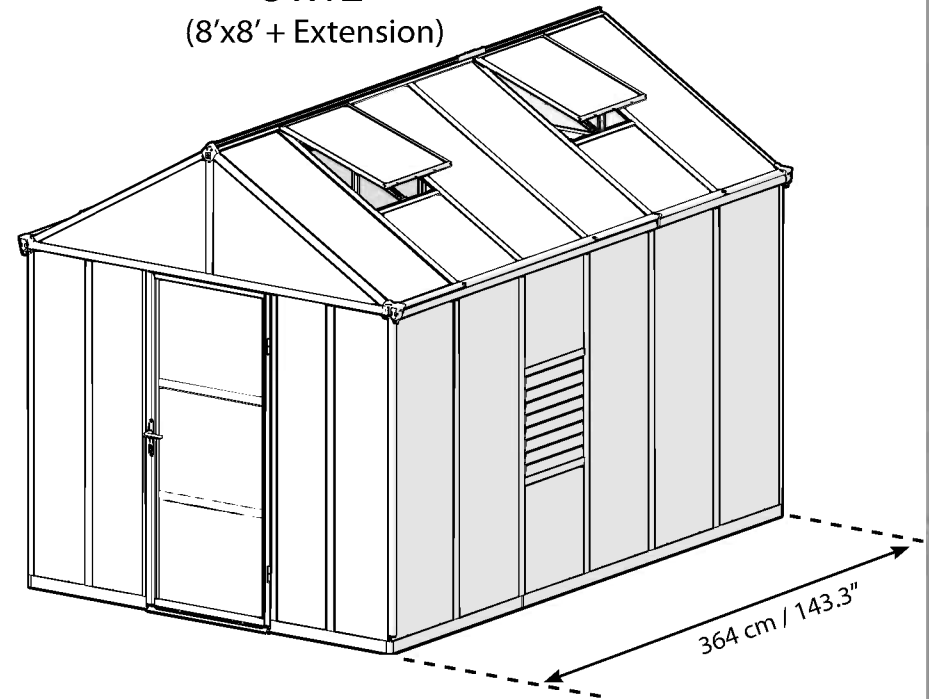





8'x8'











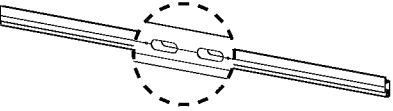



8'x12'  
(8'x8' + Extension)

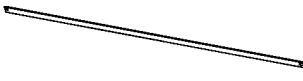



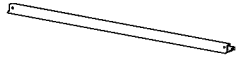







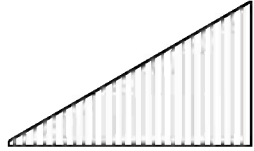
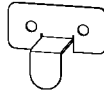
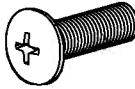
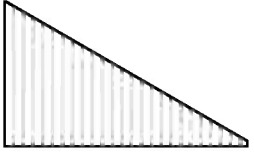
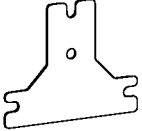

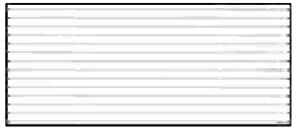



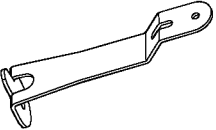
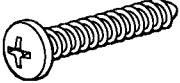
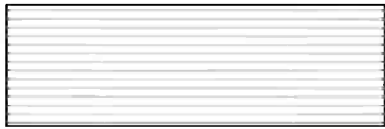
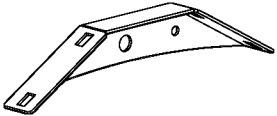

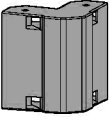
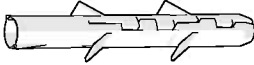

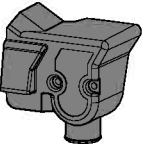
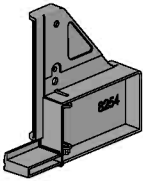
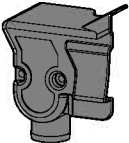
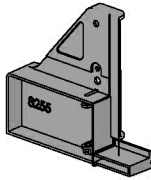

# Contents

Item		Qty.
7899		2
7599		3
8365		1
7887		2
7891		2
7885		6
7892		11
7890		1
7884		2
7880		4
7889		4



Item		Qty.
7883		2
7881		1
7882		1
7888		2
7879		1
7878		2
7886		2
256		8





Item		Qty.
7893		2
989		1
991		1
7914		2
8017		1
7868		1
7869		1



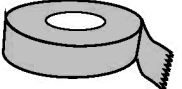

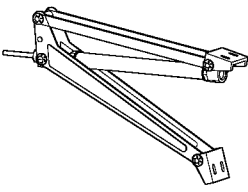
# Contents



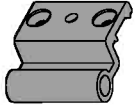
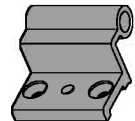

Item		Qty.	Item		Qty.	Item		Qty.
7904		2	8016		1	4016		2
7903		2	7898		6	425		2
7906		7	7894		6	413		2
7902		4	8038		8	450		14 (+2)
7901		11	8037		6	4000		8
7907	 59 x 74 cm 23"x29"	1	7602		4	4010		8
7900	 59 x 62 cm 23"x24"	3	7908		2	433		8
7905	 62 x 71.5 cm 24"x28"	3	7909		2	8254		1
			7910		2	8255		1
						461		32 (+2)
						411		112 (+15)
						466		148 (+15)
						8192		4
						7958		1
						4008		10 (+1)
						7445		4
						7442		24 (+2)
						4043		2

# Contents

Item		Qty.
T001		1
70		10
7009		2
8293		1

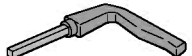
8107		1
964		2
465		4
422		4

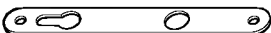
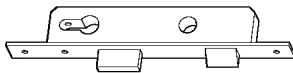
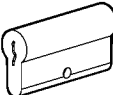
Item		Qty.
7923		4
7919		2
7918		2
7920		2
7921		2
7924		8
7922		2

Item		Qty.
7994		1
7995		1
7996		2
7948		2
7912		1
7913		1
8039		3
7993		1

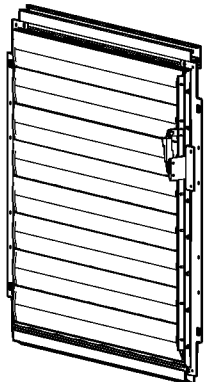
7943		1
------	---	---

# Contents Extension Kit

Item	Qty.	Item	Qty.	Item	Qty.	Item	Qty.
7601	2	8107	1	7898	2	461	16 (+2)
7597	2	964	2	7894	4	411	44 (+5)
7885	4	465	4	7944	2	466	64 (+7)
7892	4	422	4	7930	1	7442	16 (+2)
7926	1	7914	2	7929	2	4008	2 (+5)
7927	2	7911	2	7931	1	4000	2
7928	2	7900	1	8038	2	4010	2
989	1	7907	1	8037	3	433	2
991	1	7906	3			7009	2
7878	2	7901	4				2
7890	1						2

1

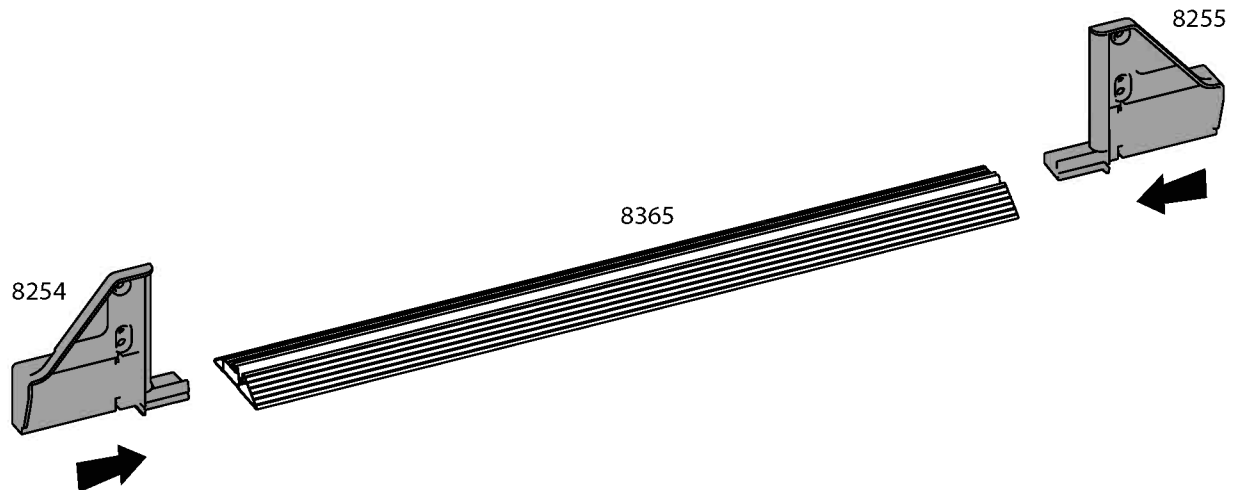
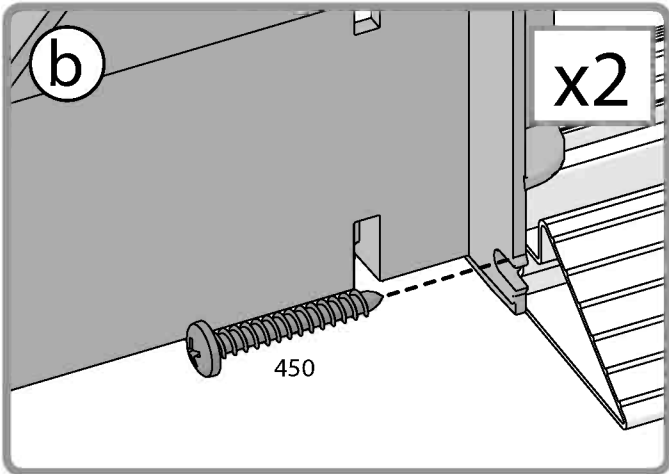
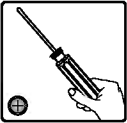
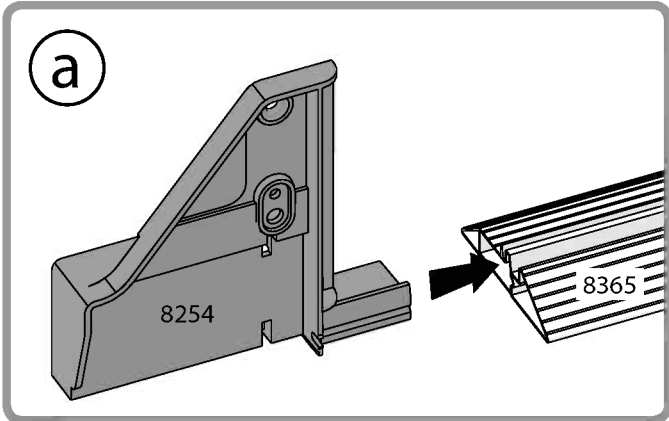
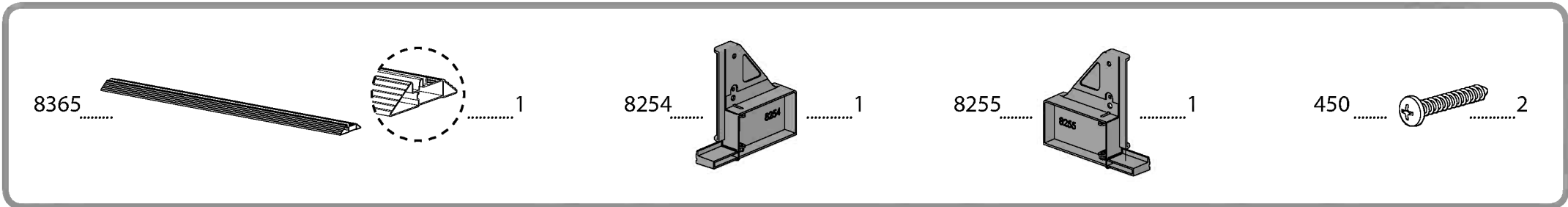
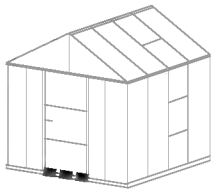

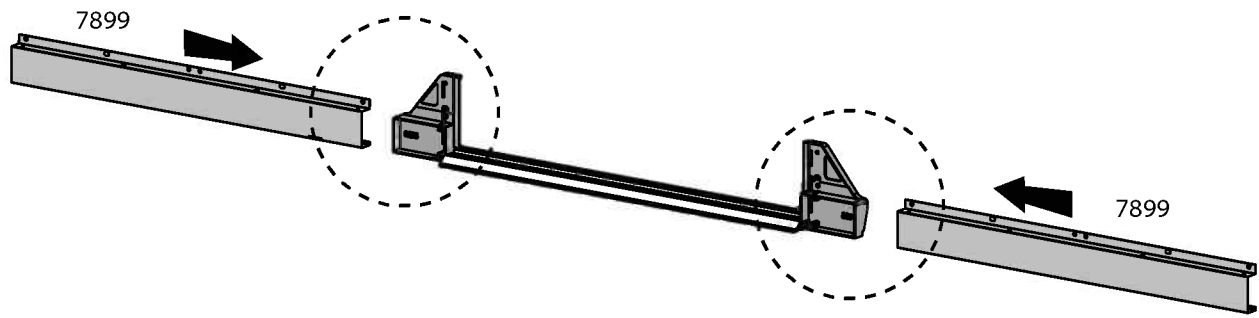
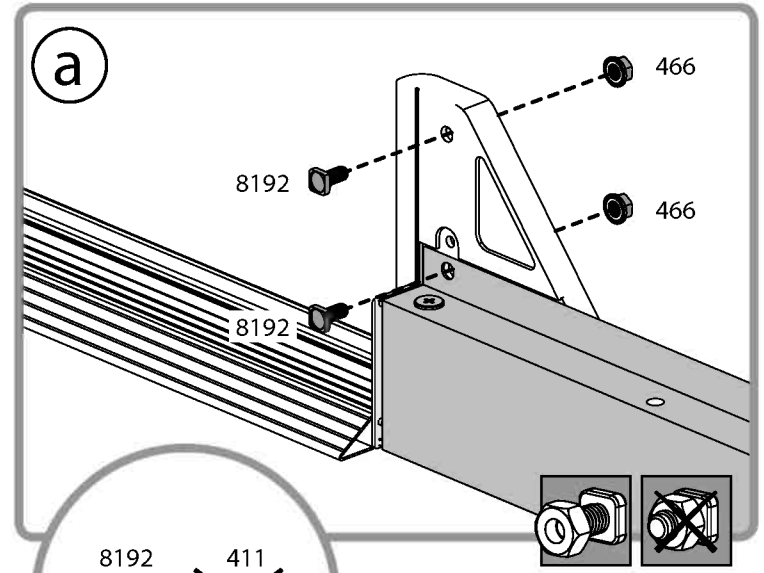
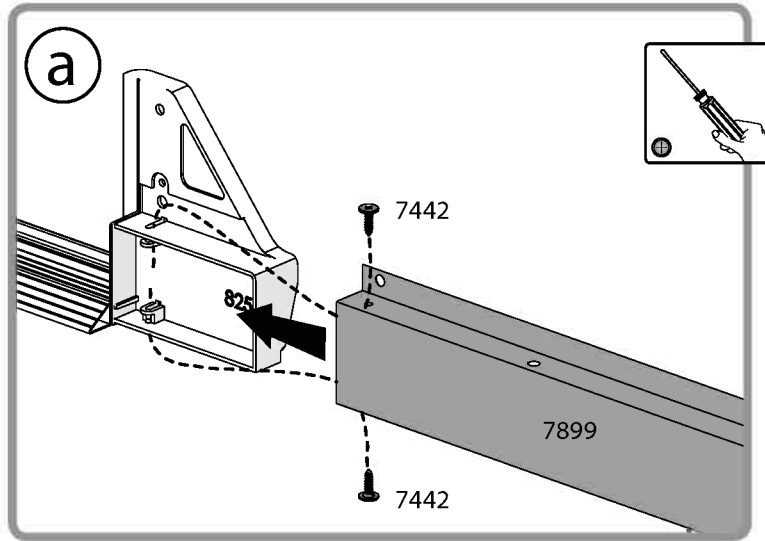
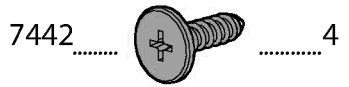
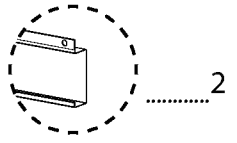
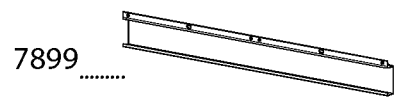
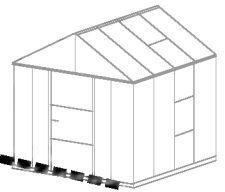



### 3 For Extension Kit Only

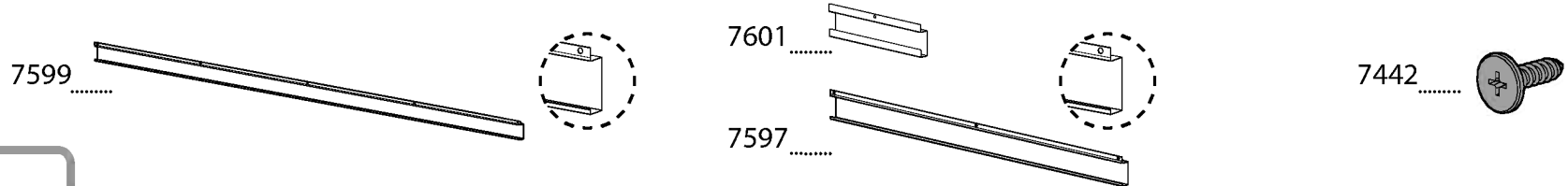
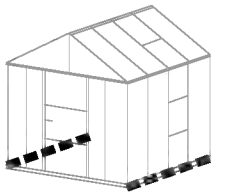

Extension Kit

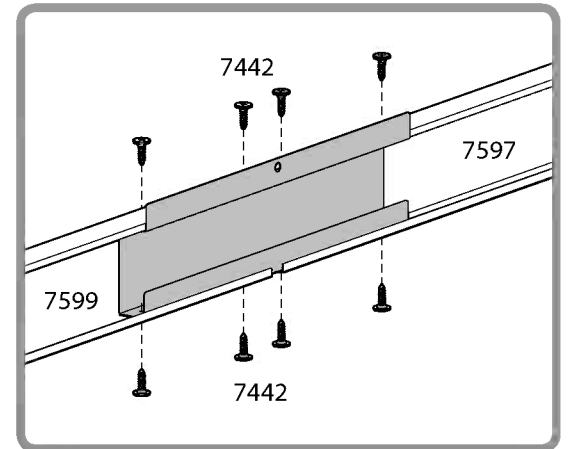
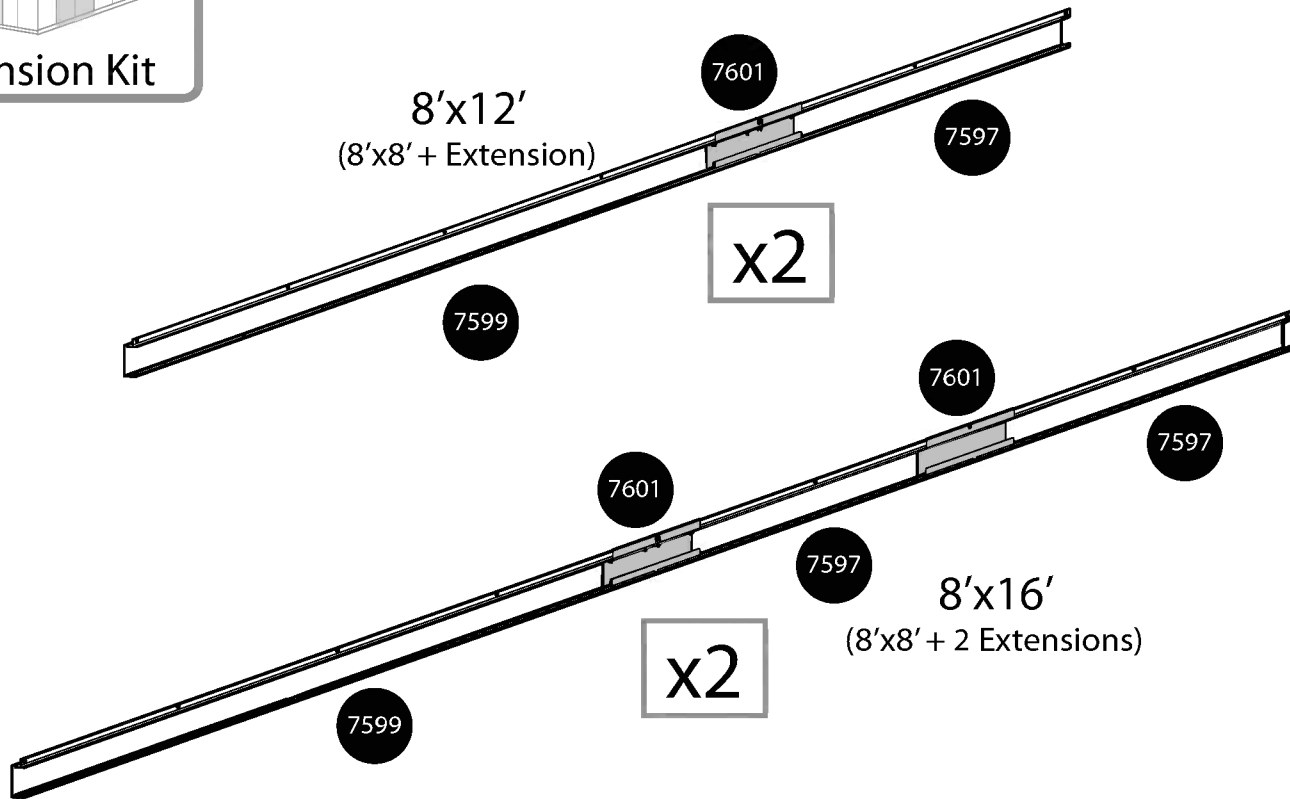

4

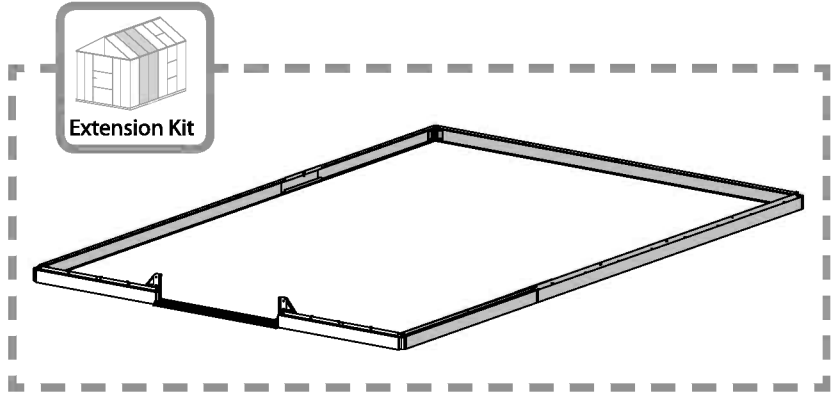
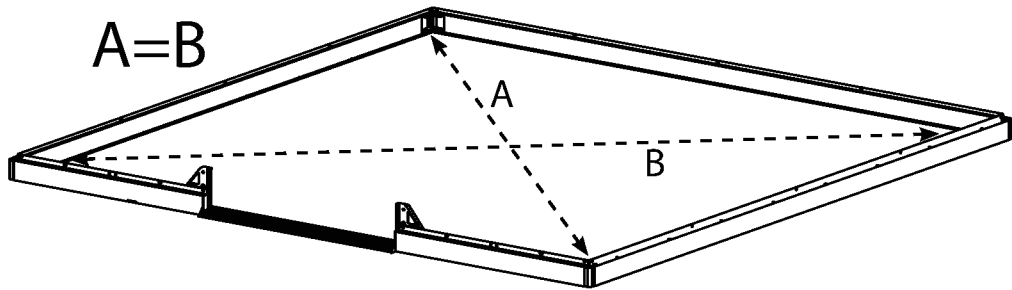
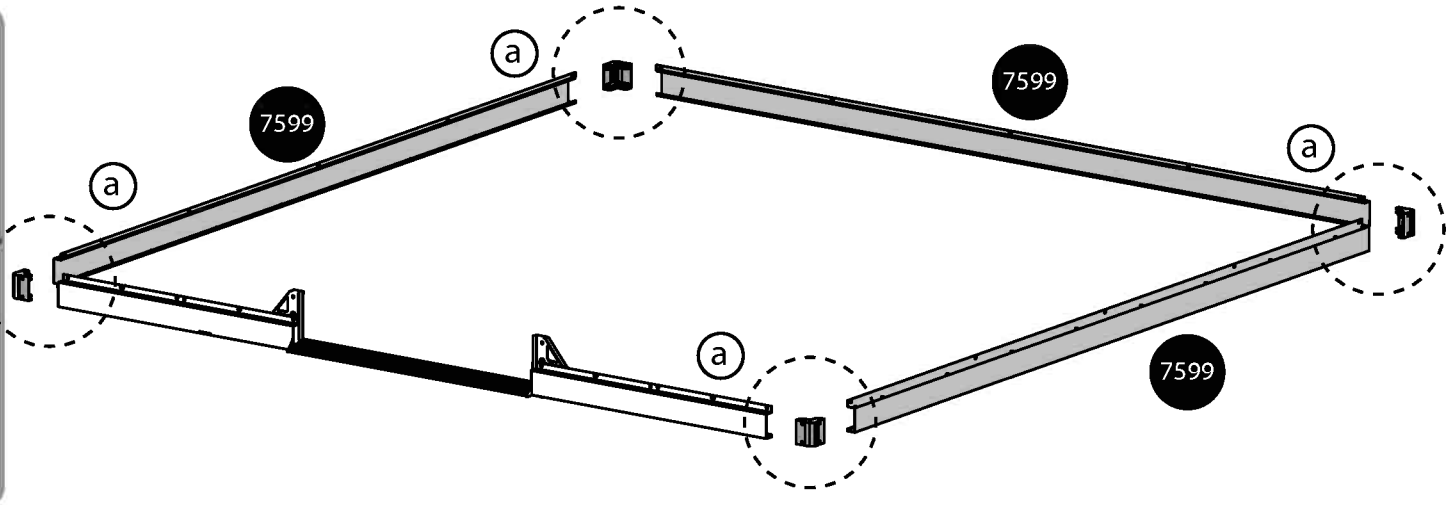
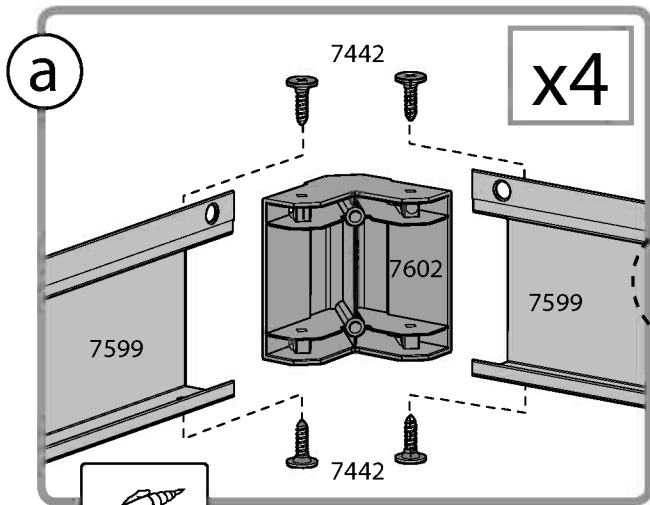
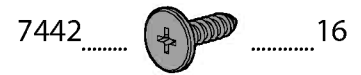
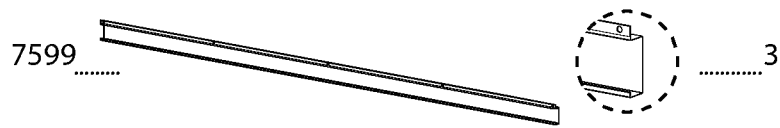
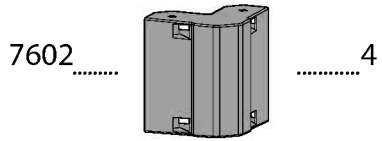
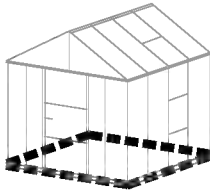

5

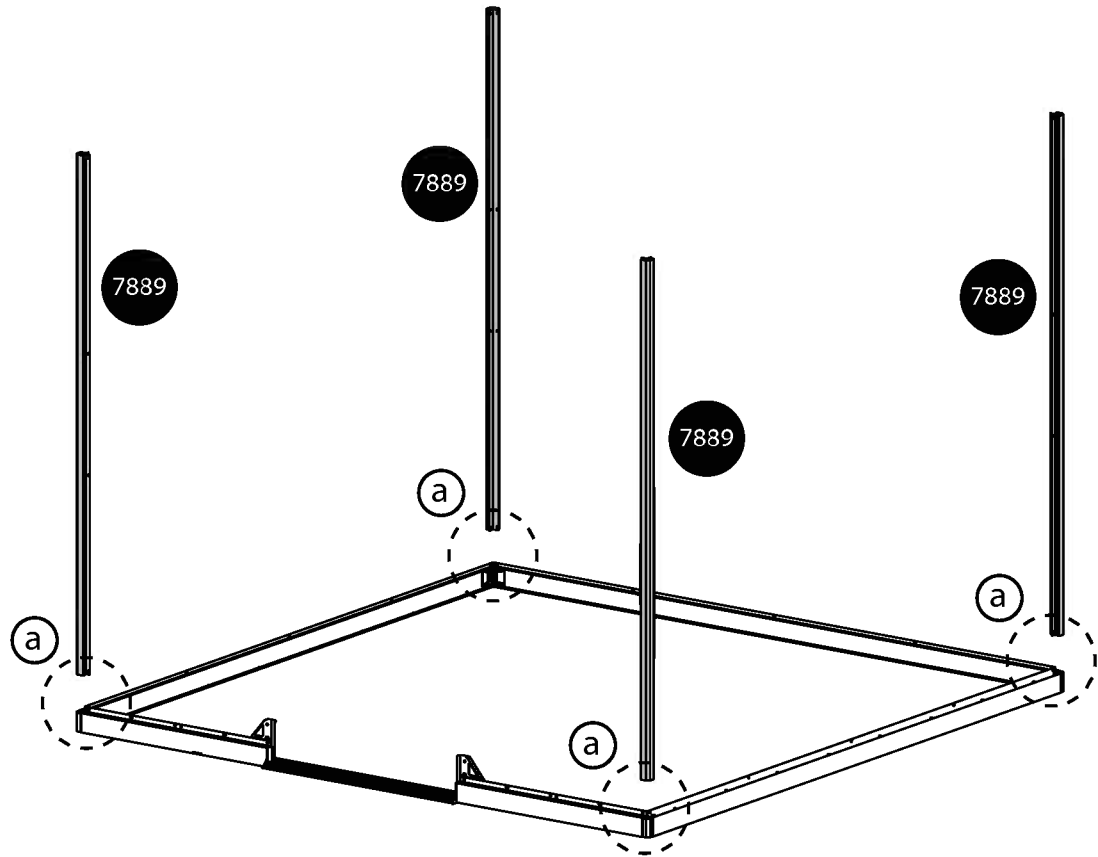
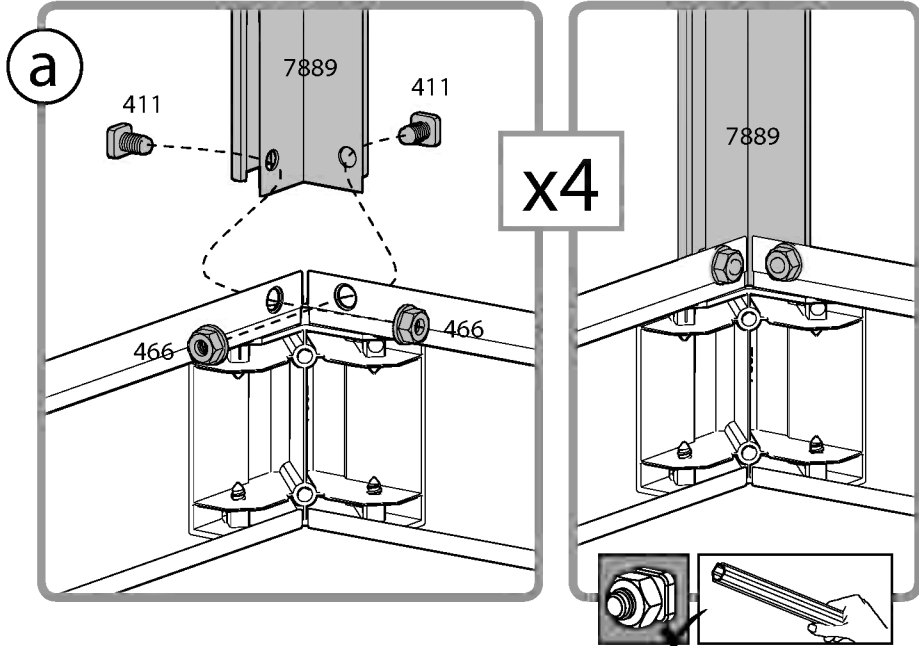
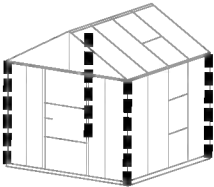

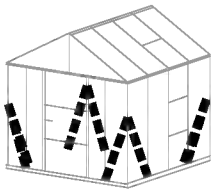

- 256..... 
-  ..... 8
- 411.....  ..... 16
- 466.....  ..... 16

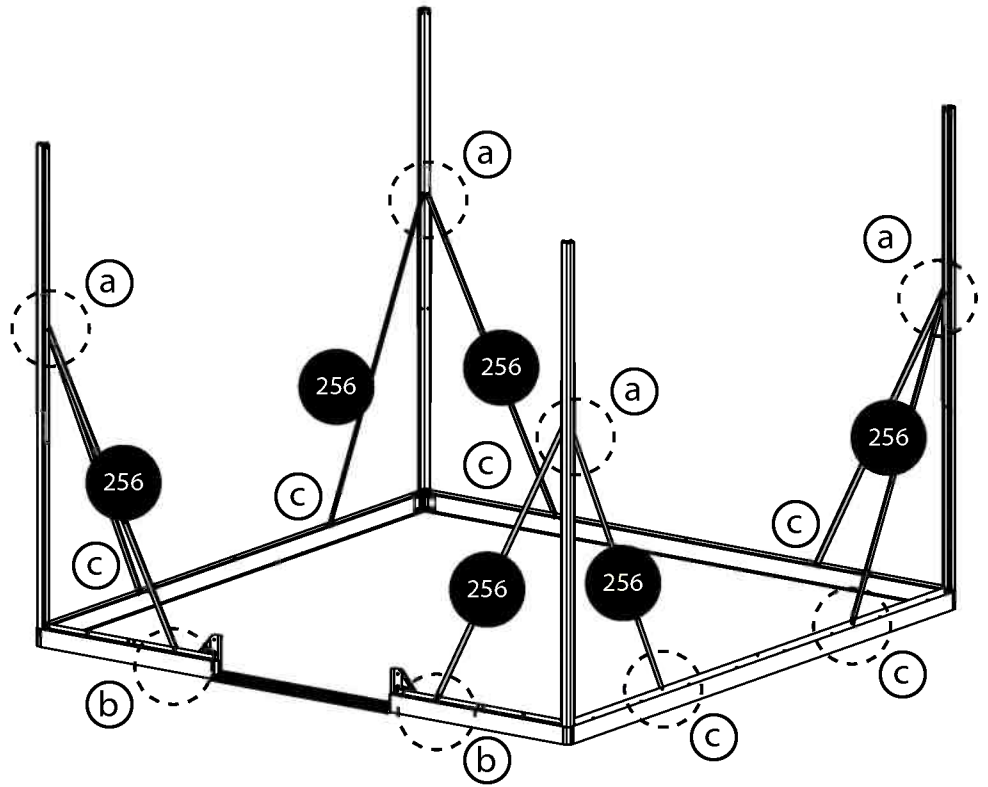
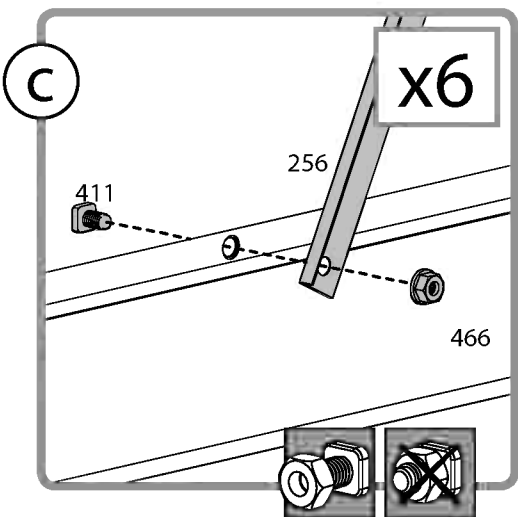
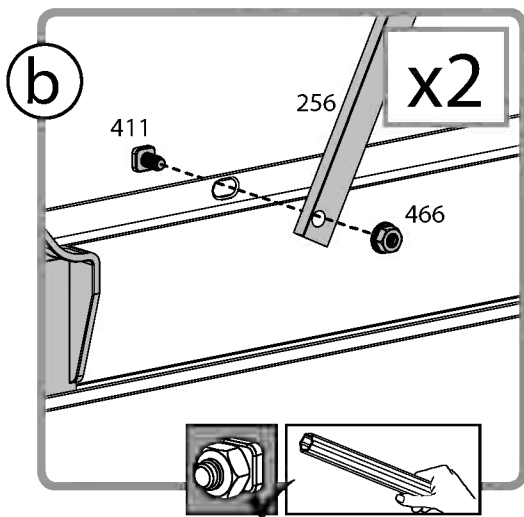
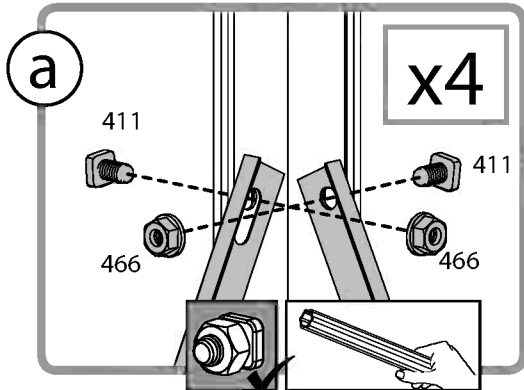

# 7 For Extension Kit Only

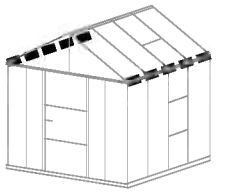

- |      |  |         |      |  |         |     |  |          |
|------|--|---------|------|--|---------|-----|--|----------|
| 7883 |  | ..... 2 | 7929 |  | ..... 2 | 411 |  | ..... 12 |
| 7928 |  | ..... 2 | 7944 |  | ..... 2 | 466 |  | ..... 12 |

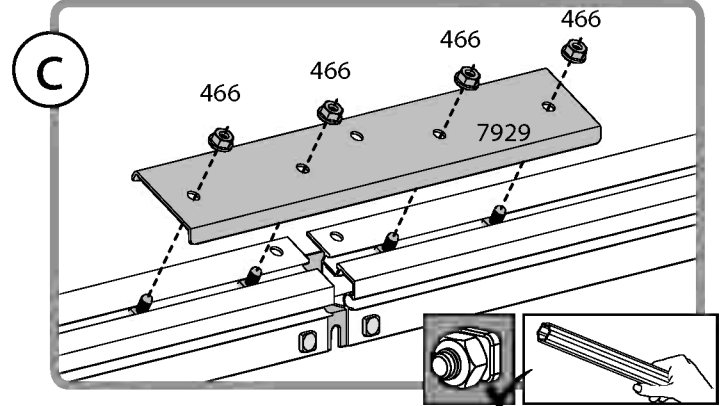
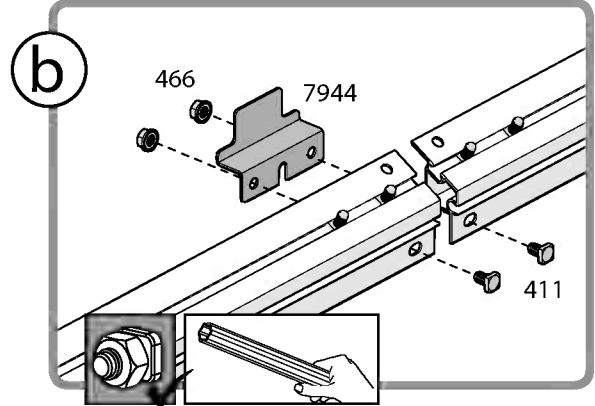
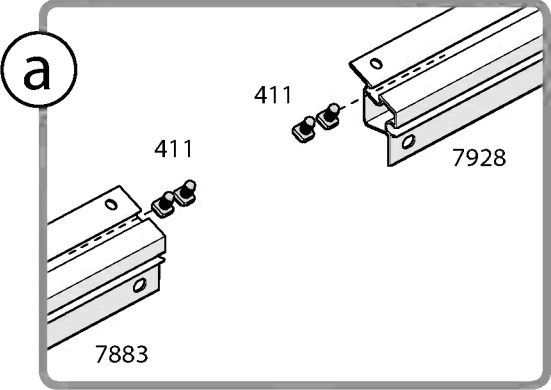
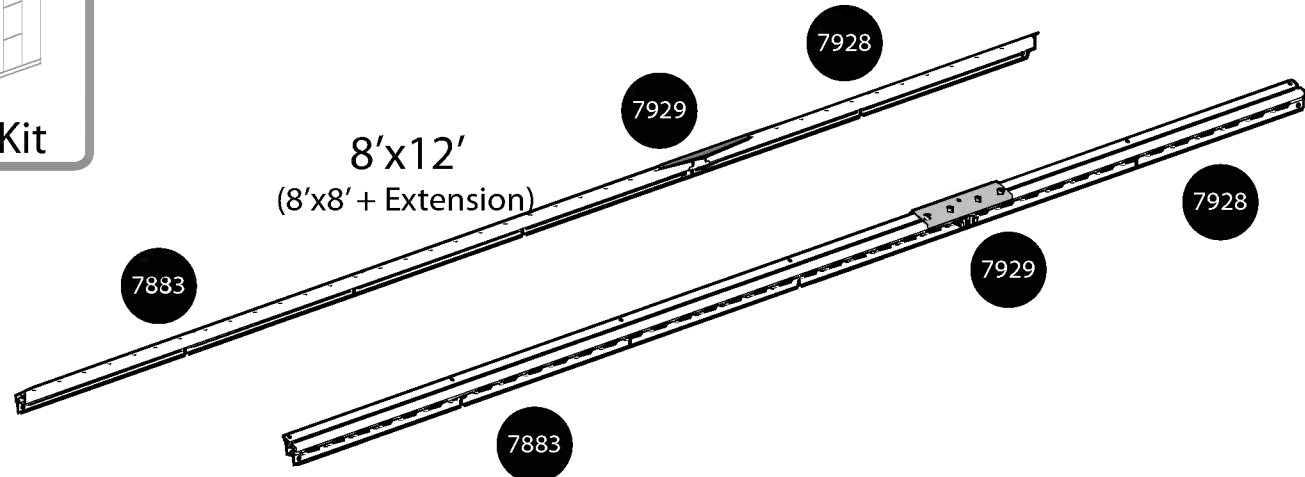

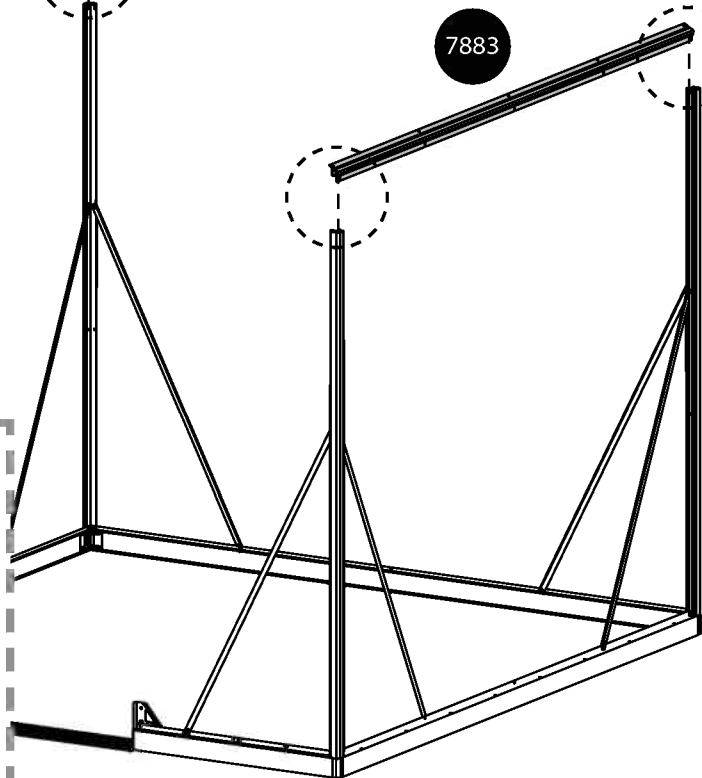
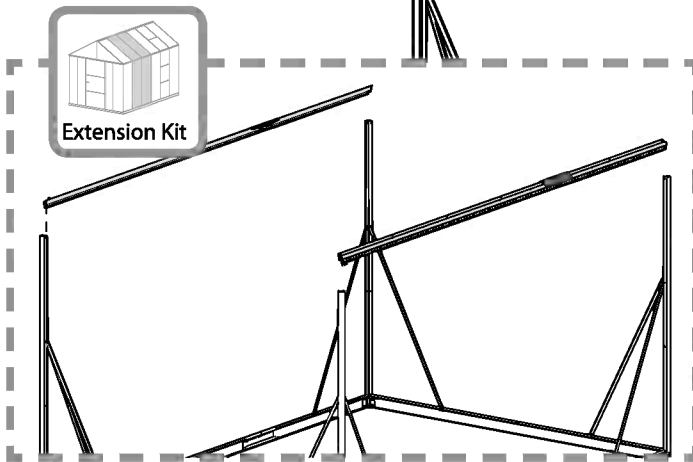
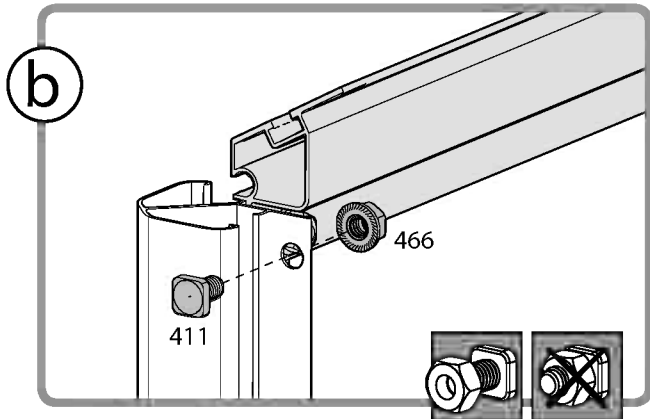
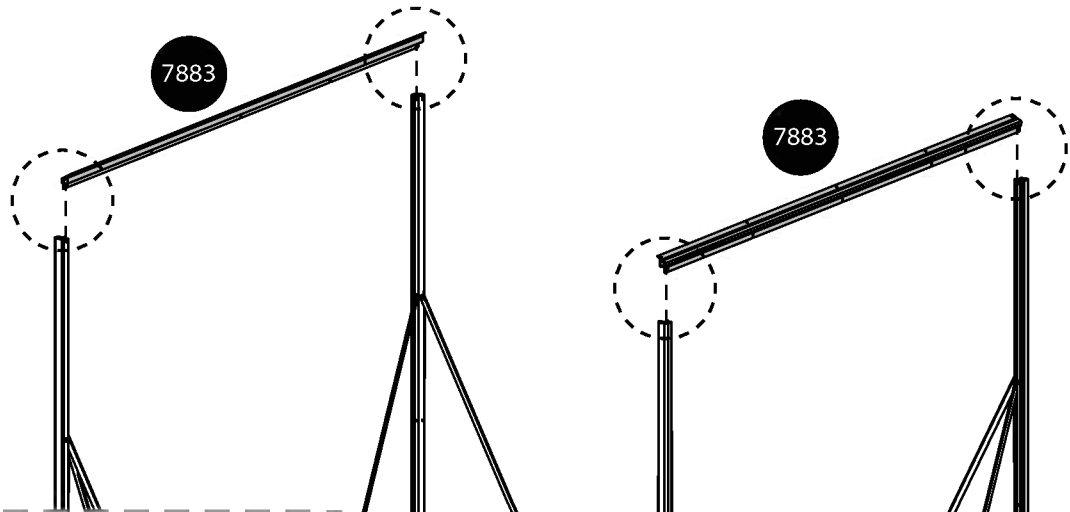
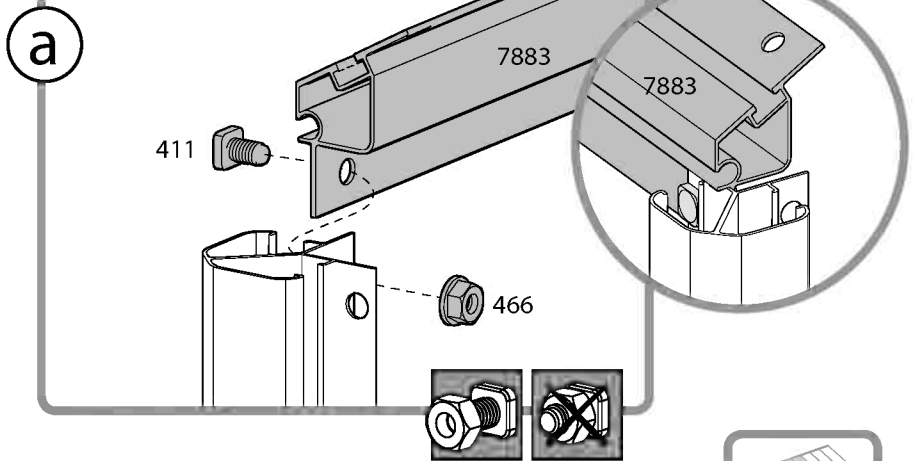
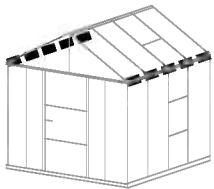

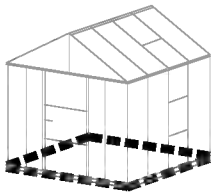

411 .....  ..... 5

466 .....  ..... 5



411 ..... +4

466 ..... +4

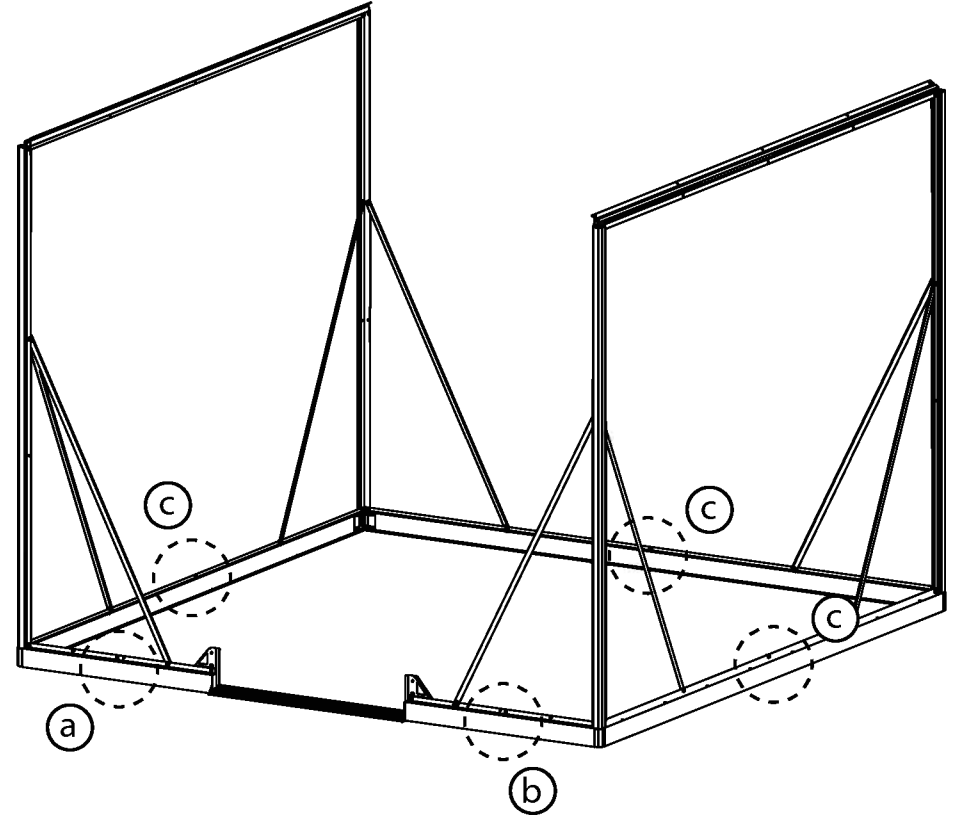
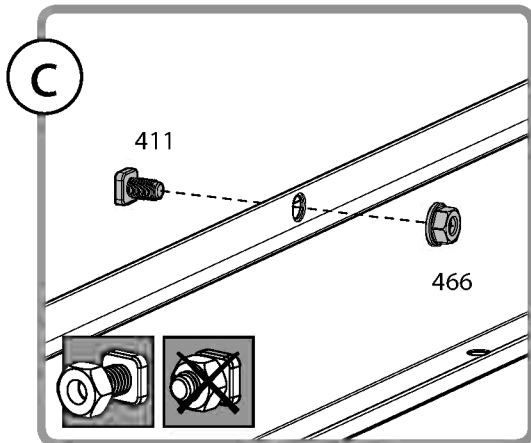
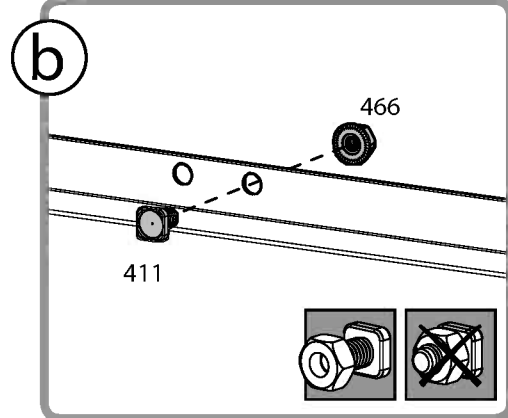
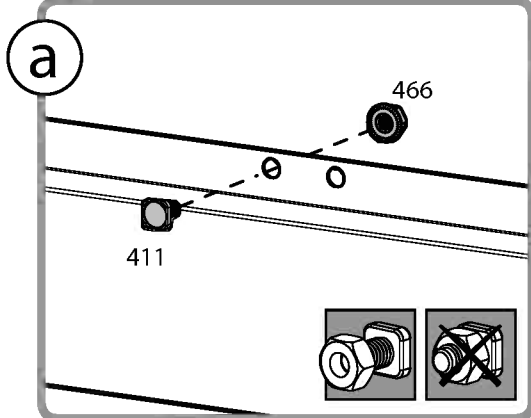

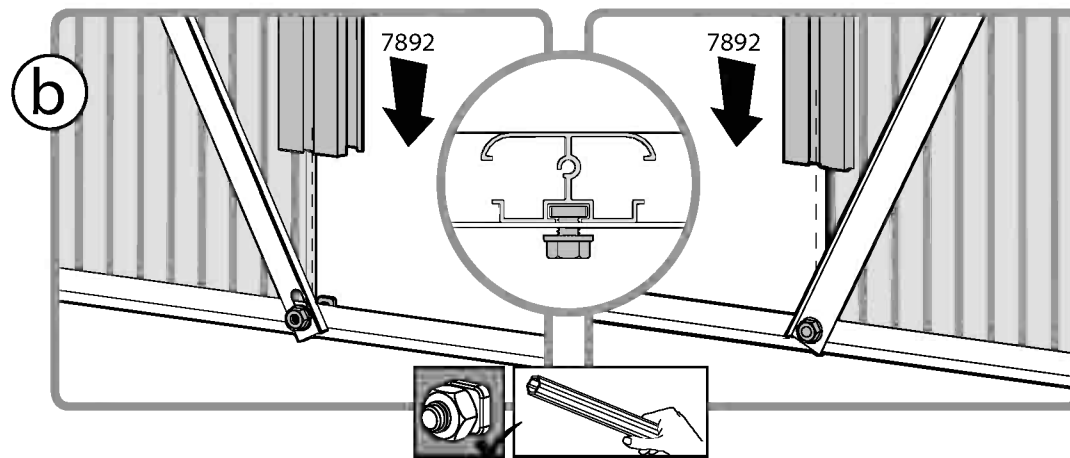
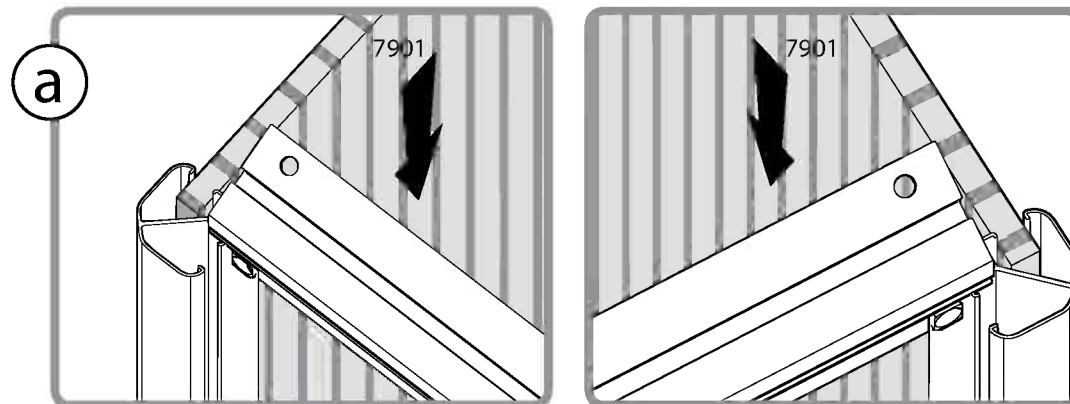
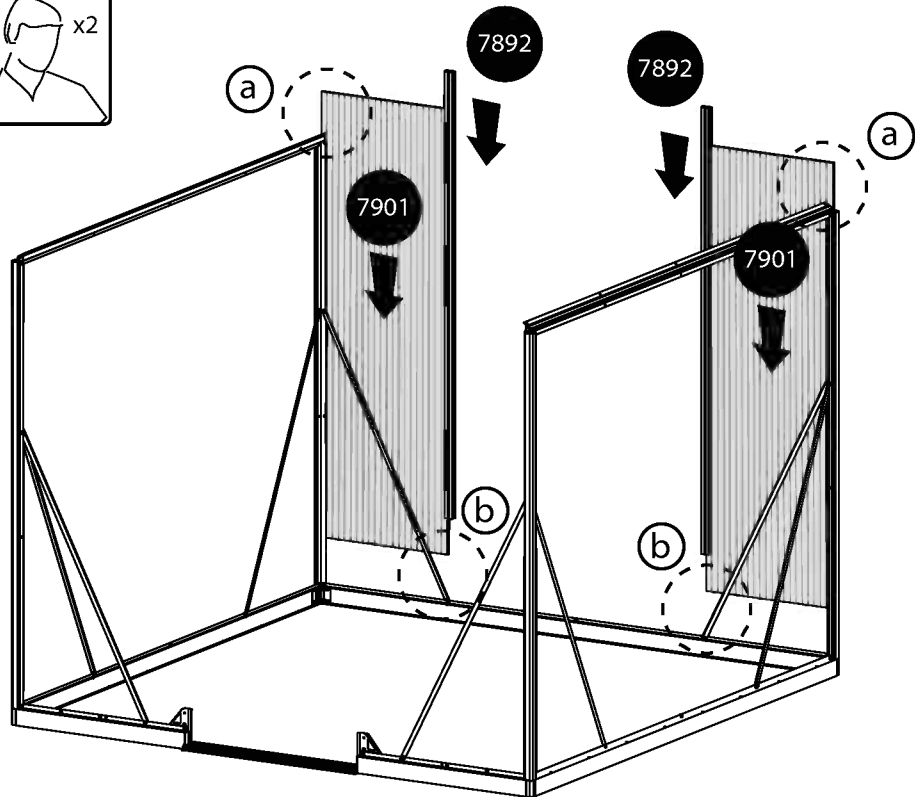
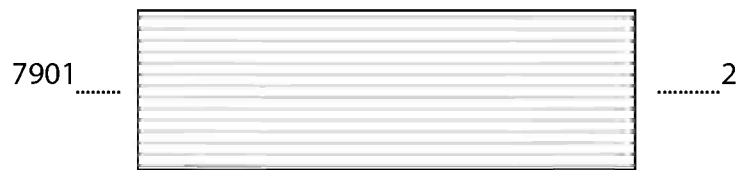
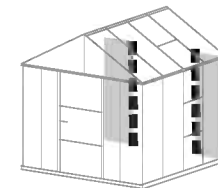



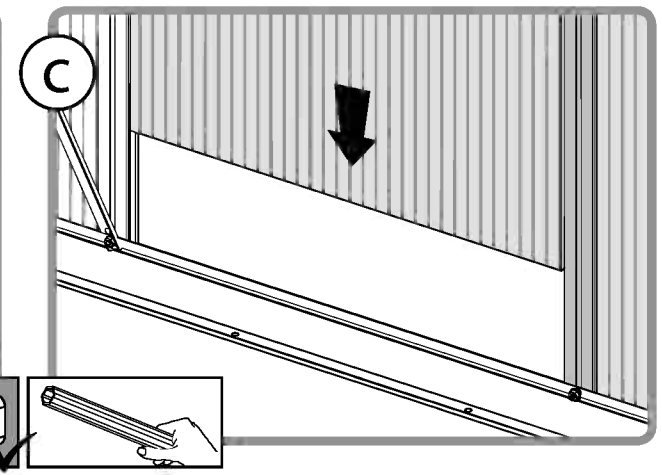
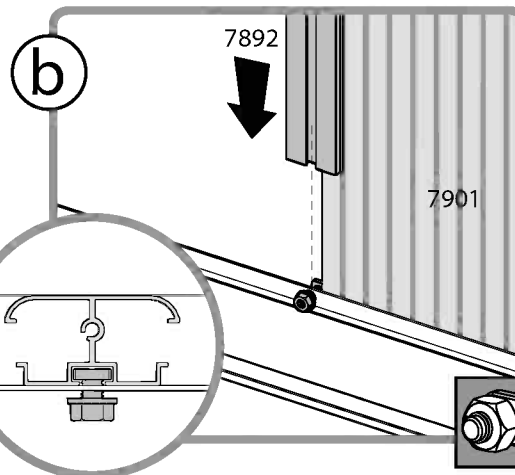
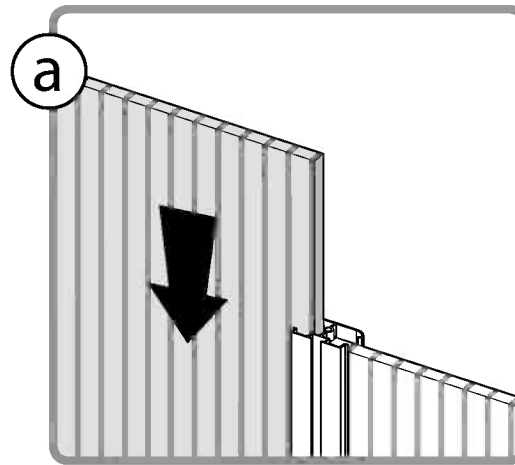
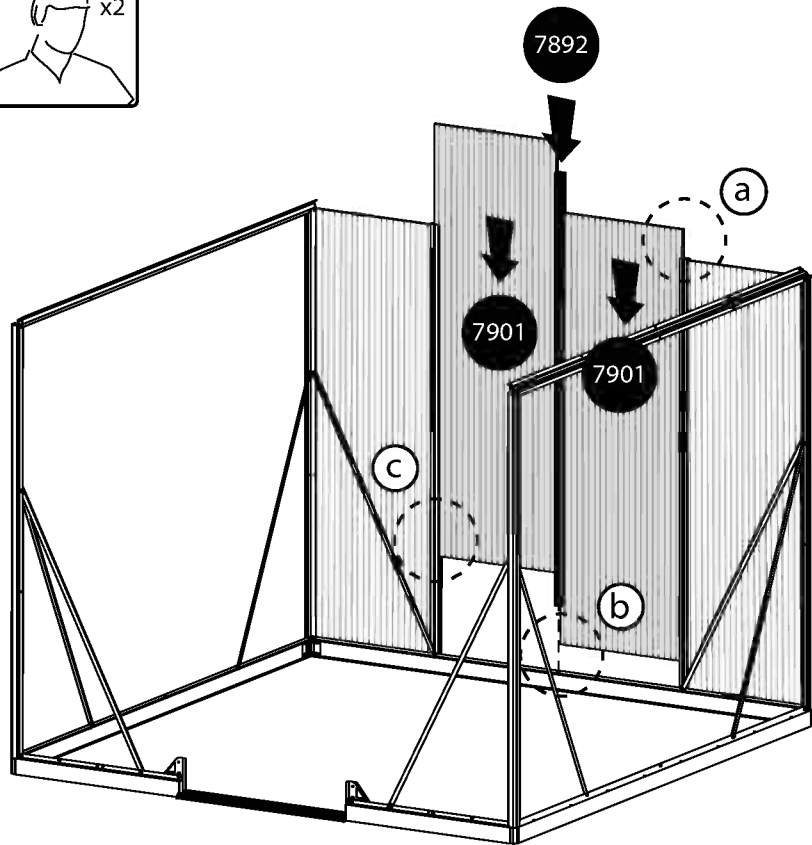
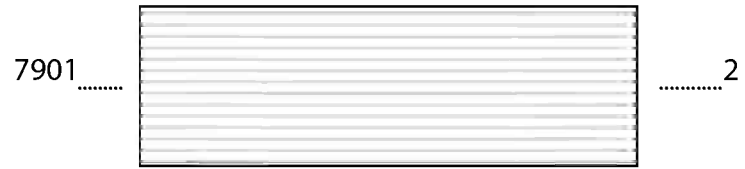
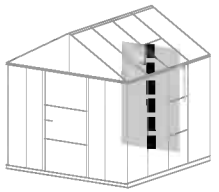

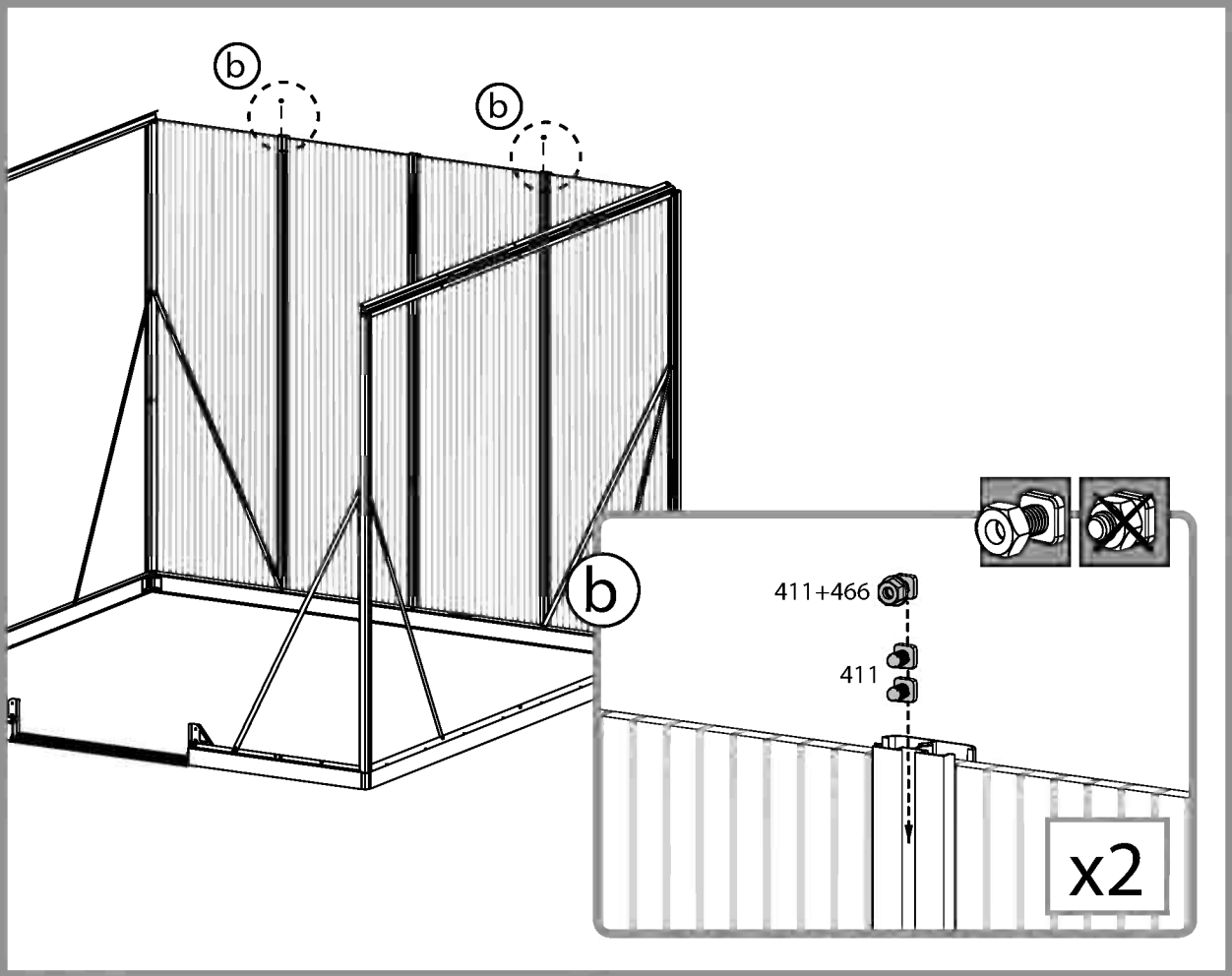
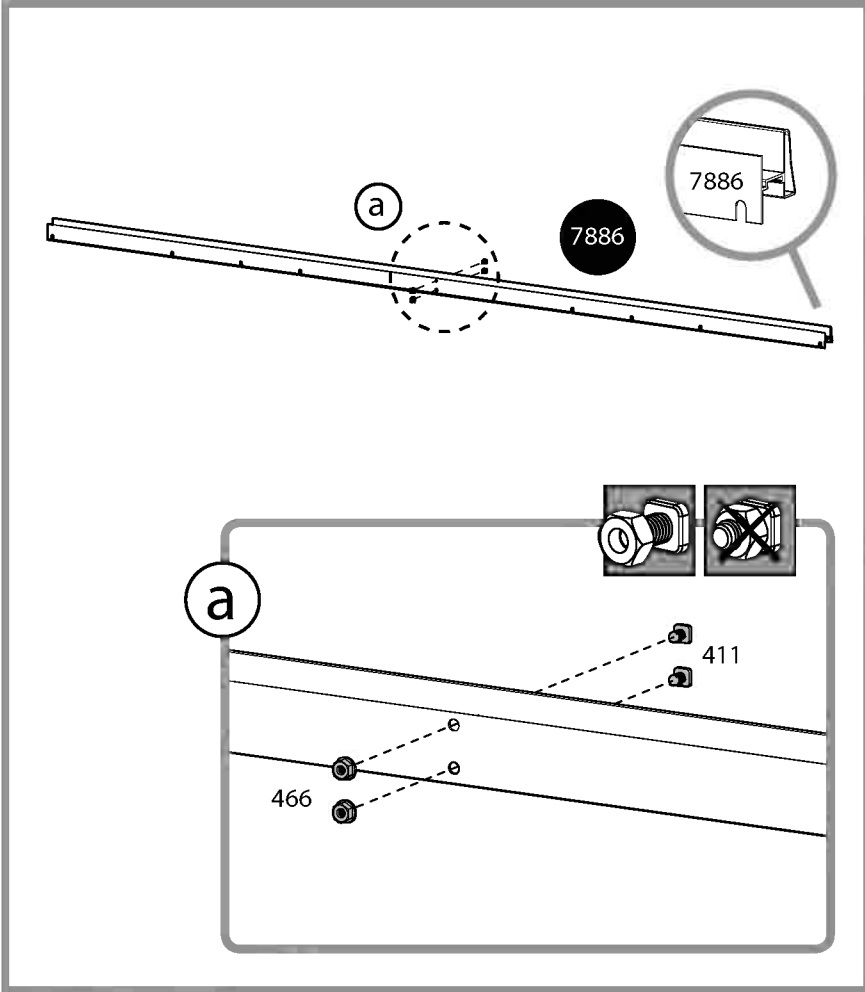
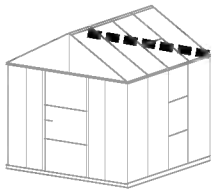

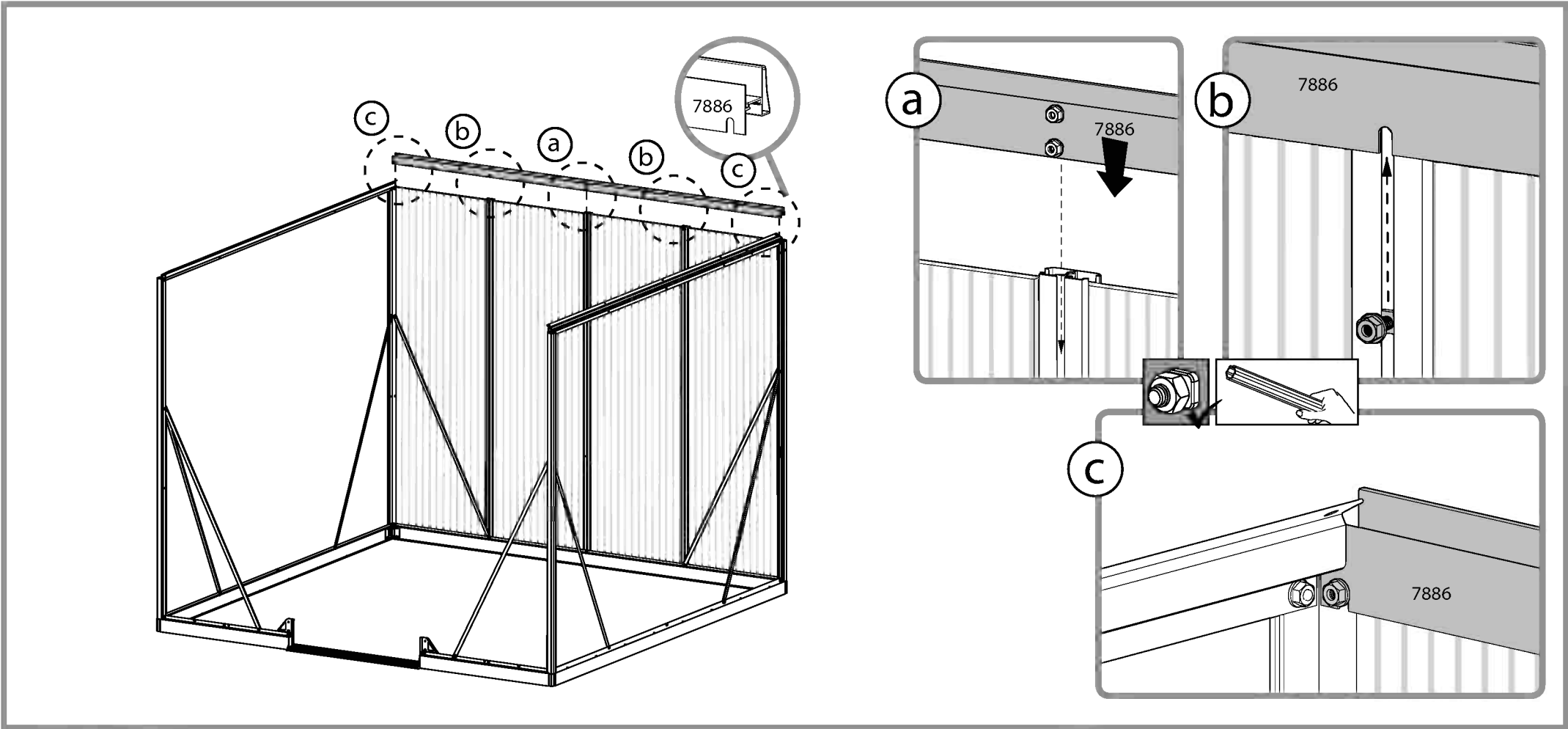
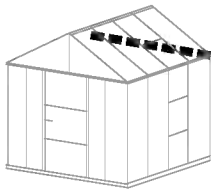

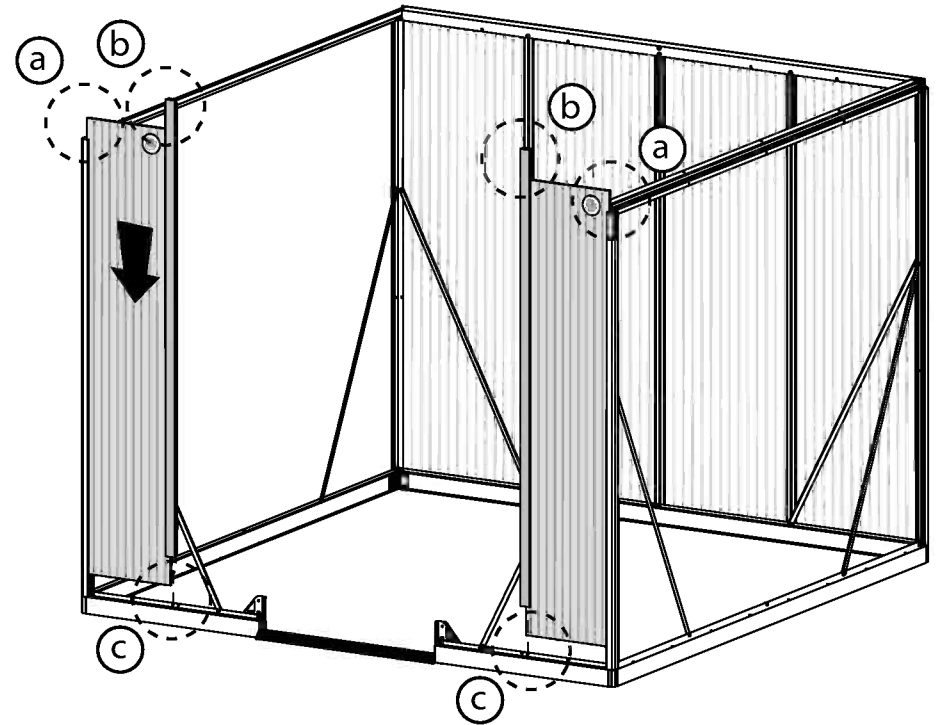
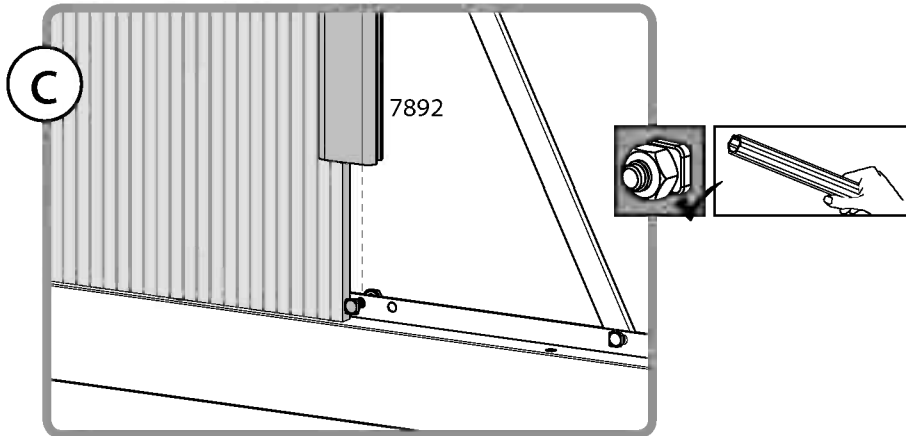
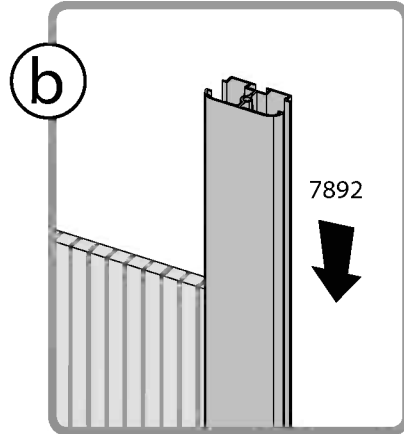
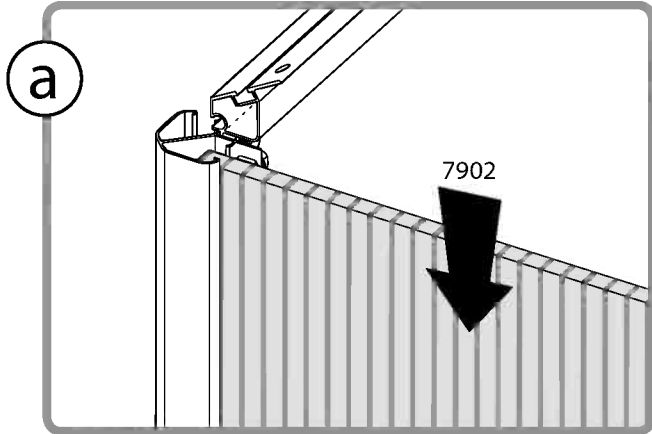
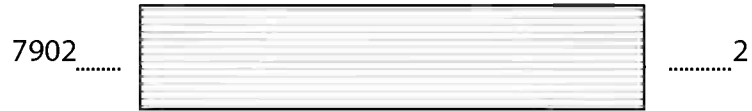
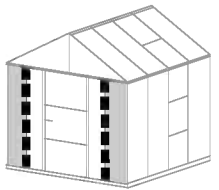

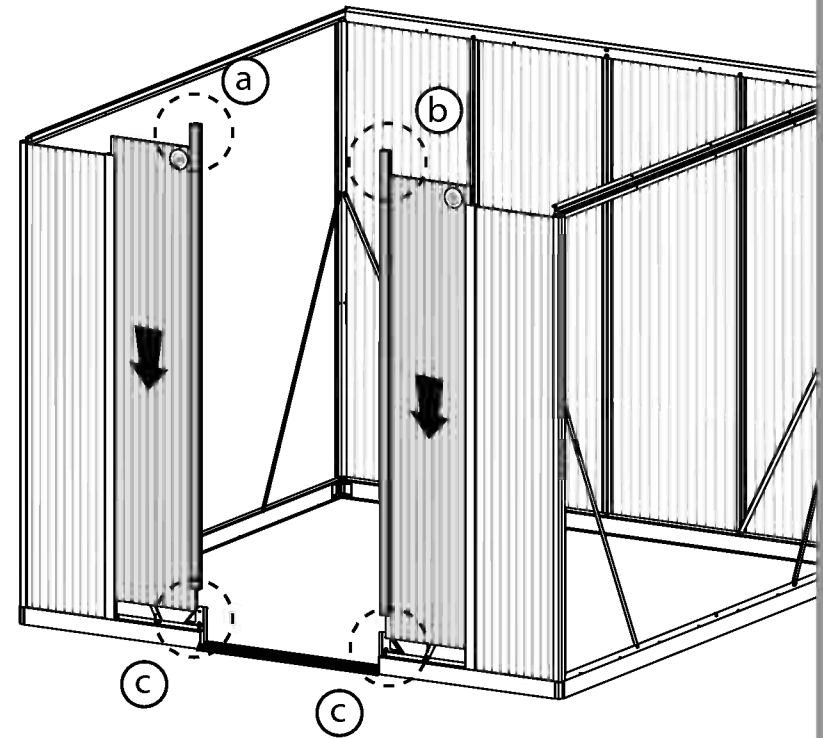
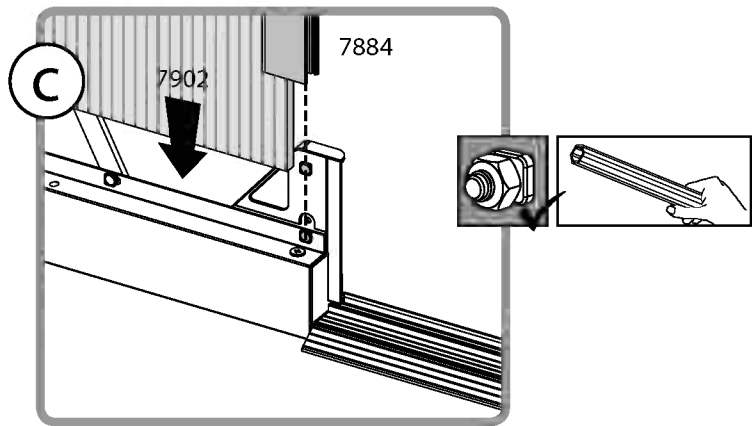
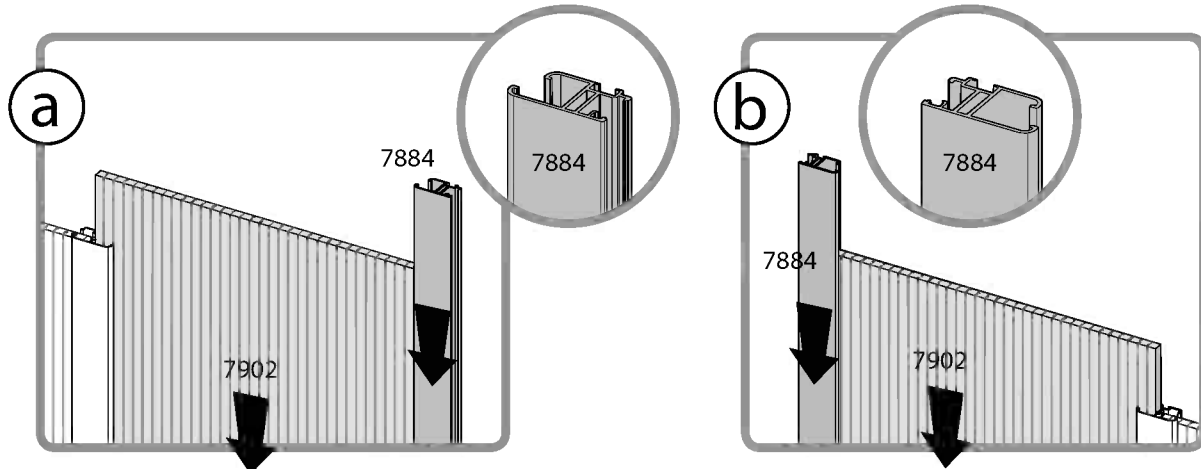
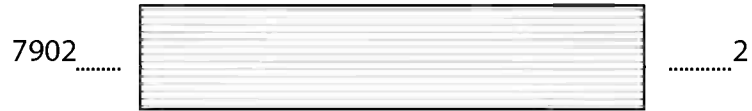
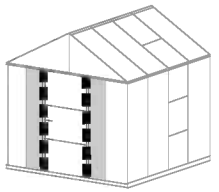

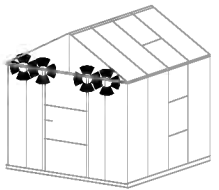



411.......... 8

466.......... 4

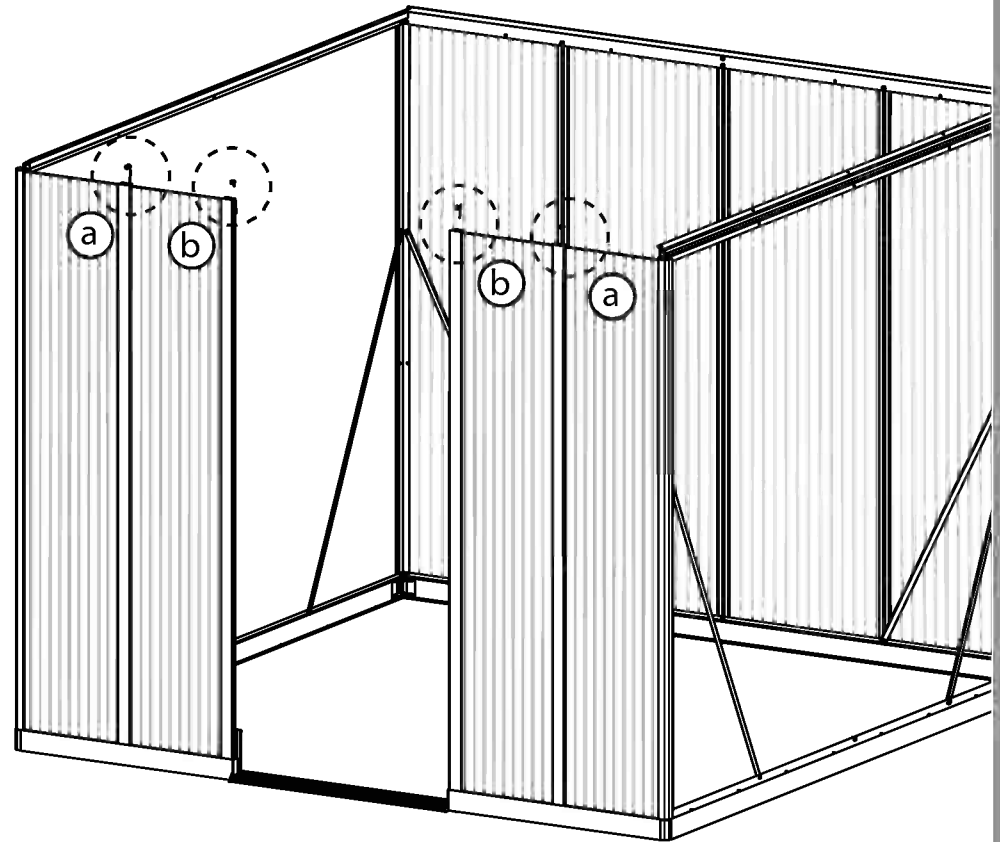
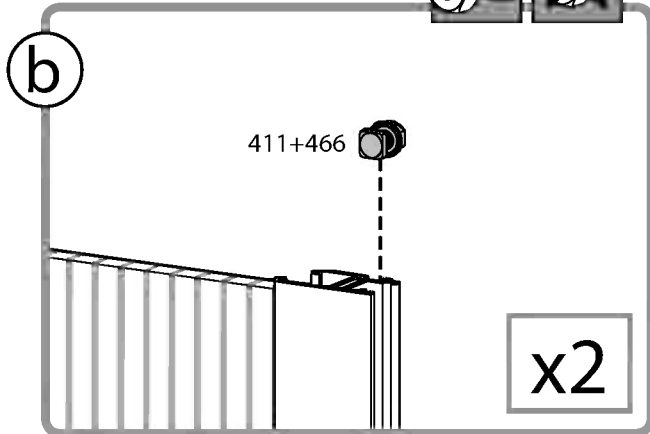
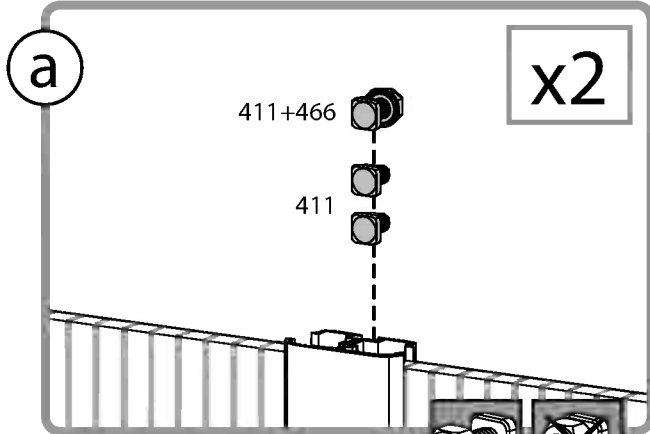

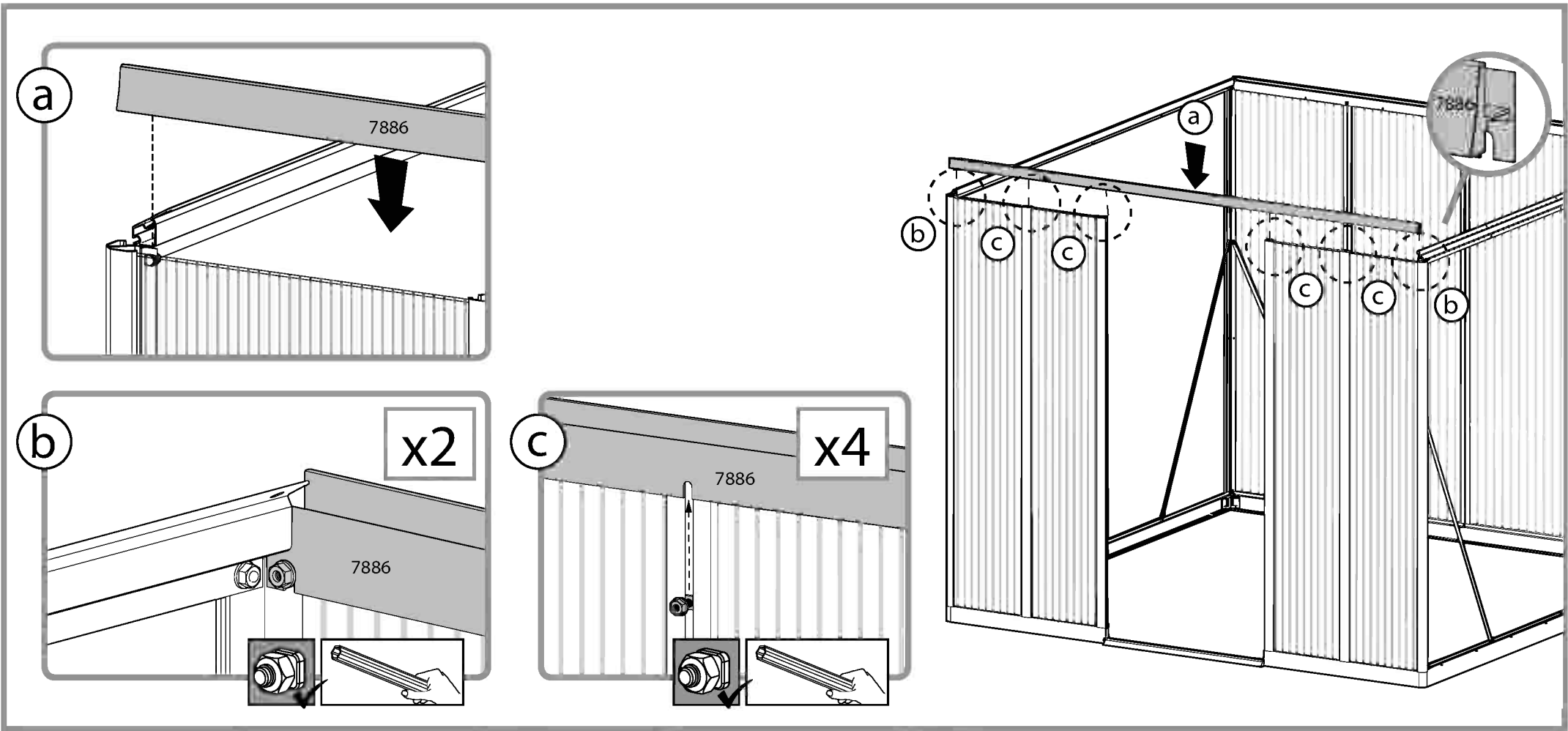
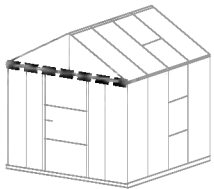

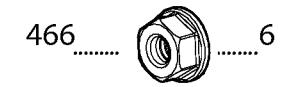
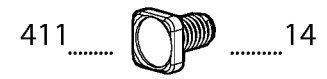
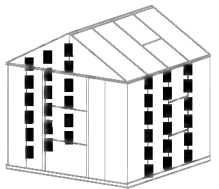

- 7892..... +4
- 411..... +4
- 466..... +4

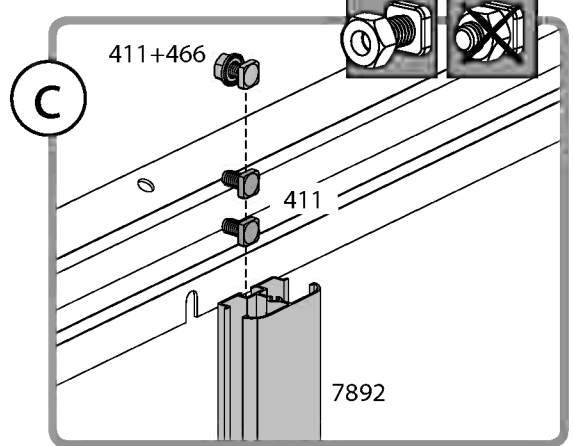
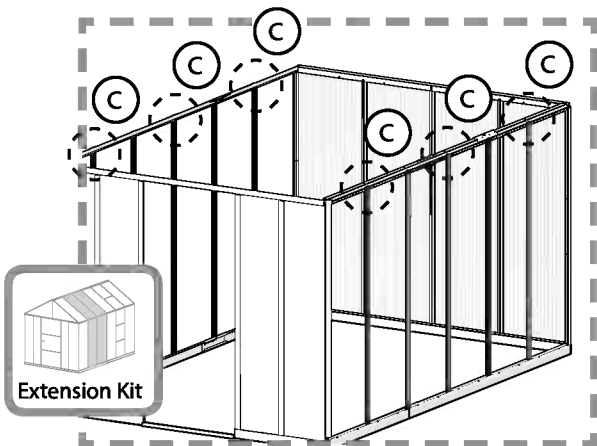
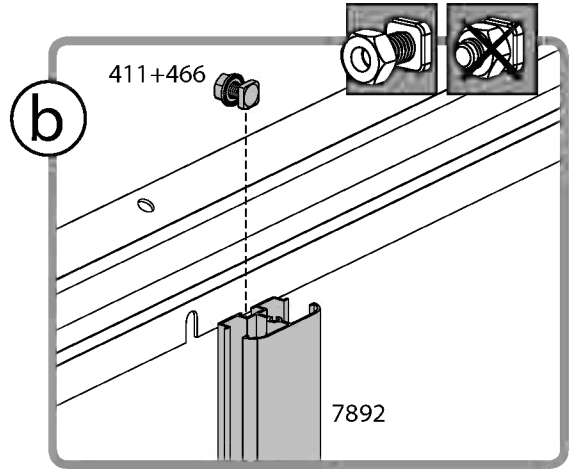
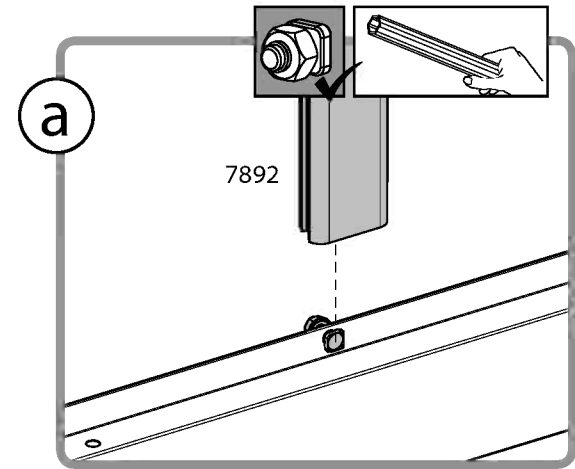
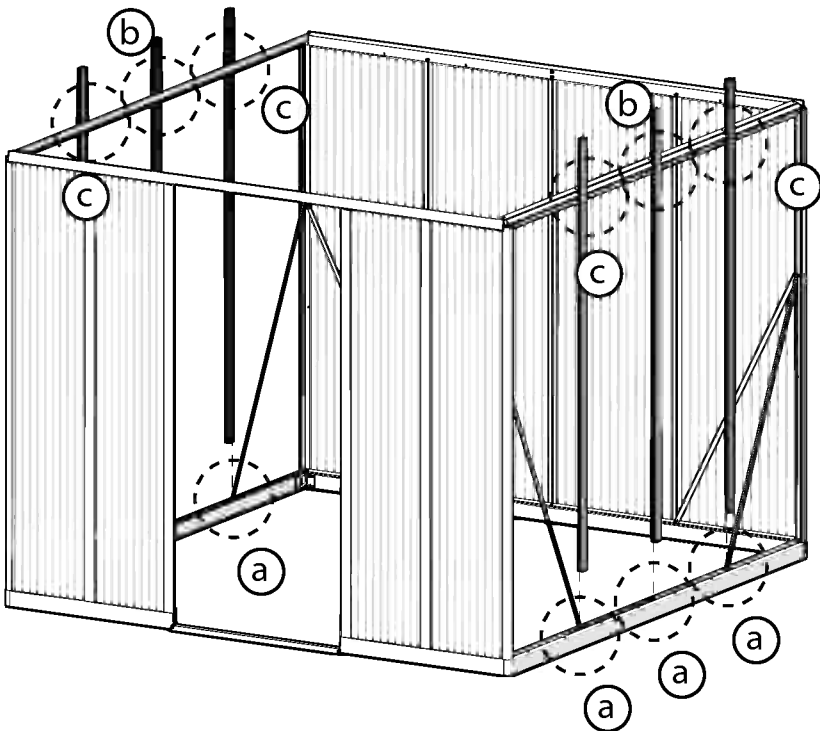



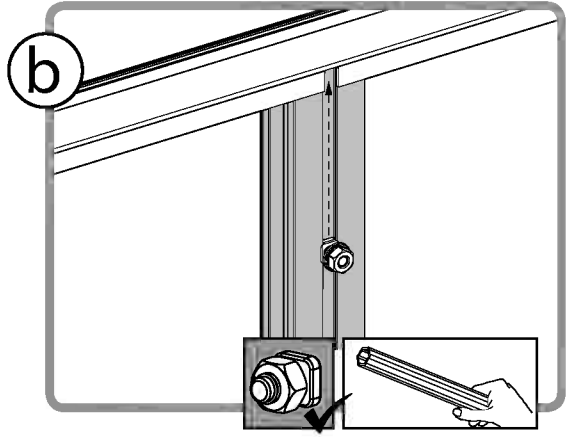
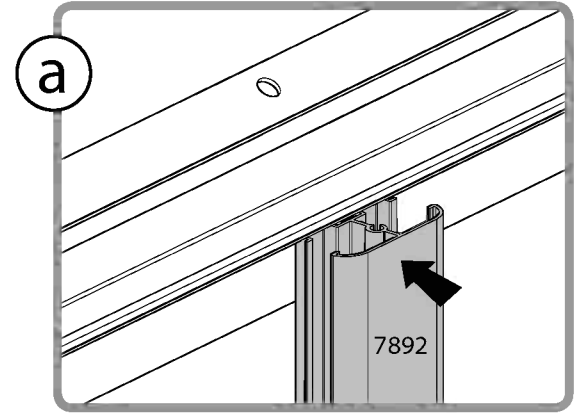
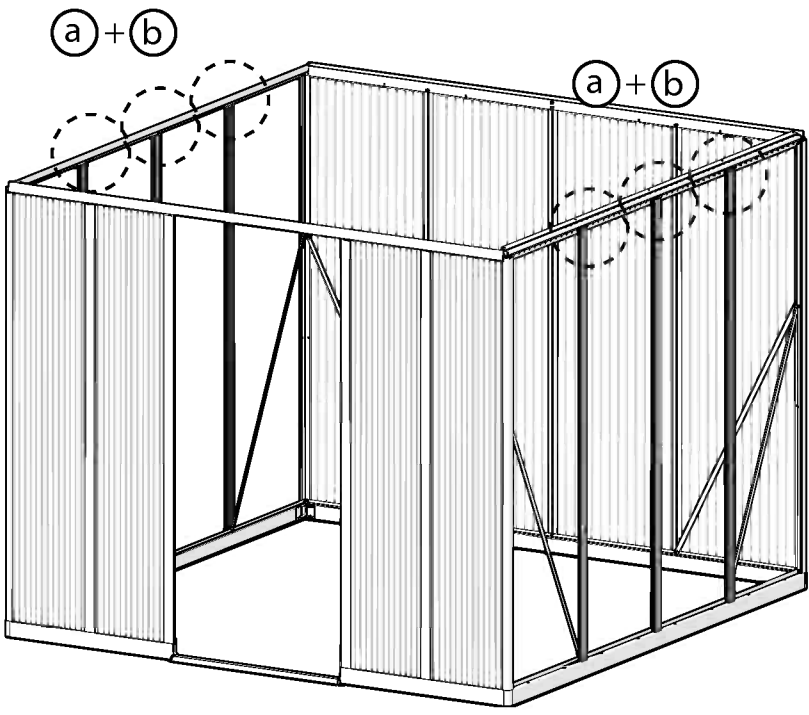
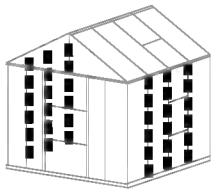

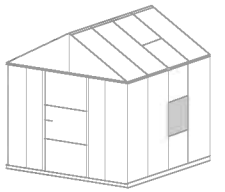

7943

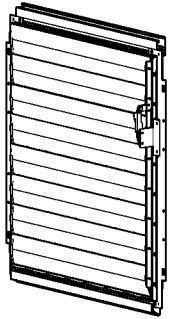

1

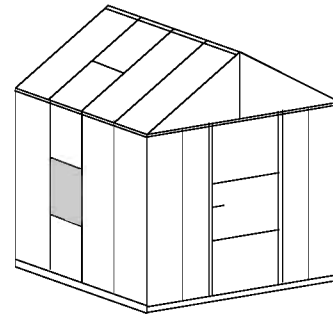
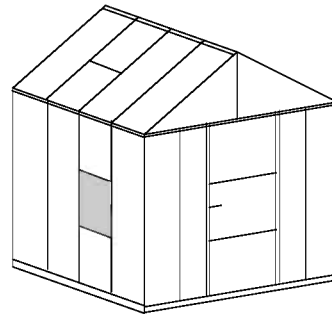
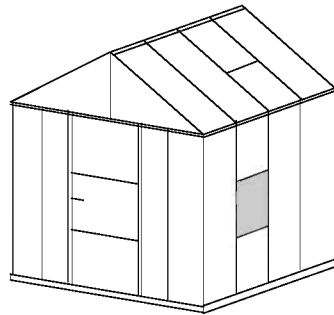
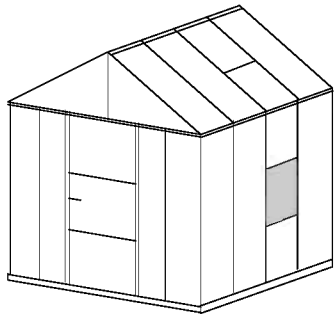

Extension Kit

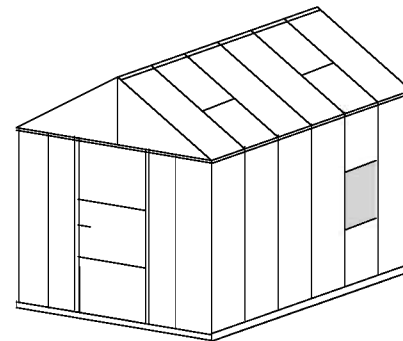
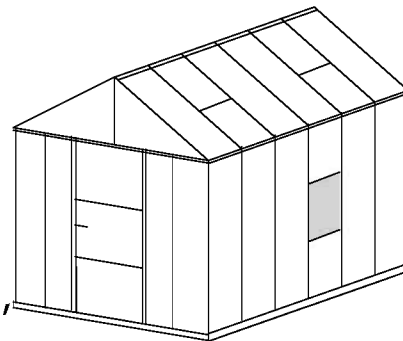
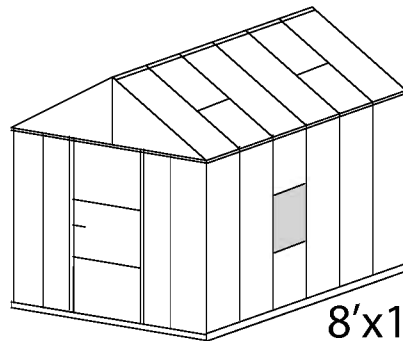
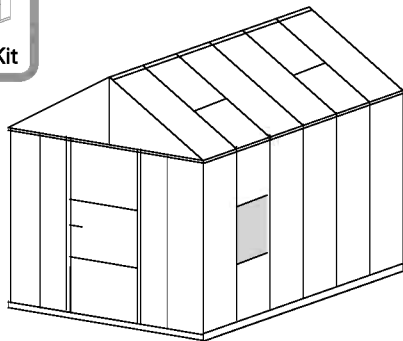

8'x12'  
(8'x8' + Extension)

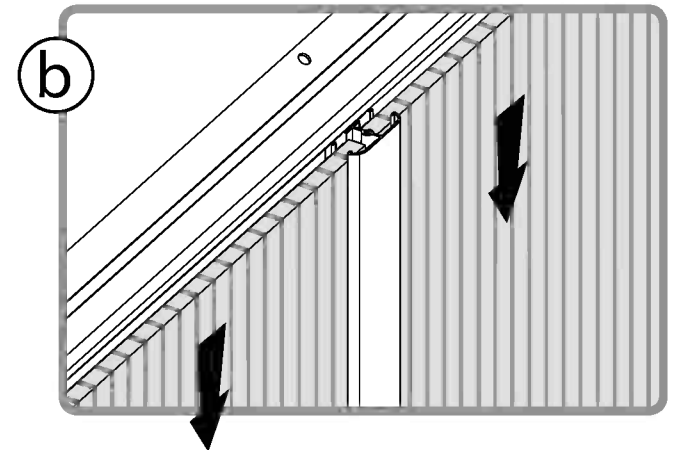
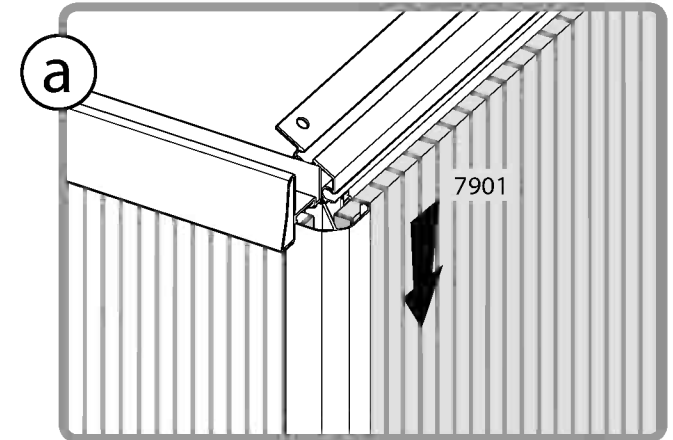
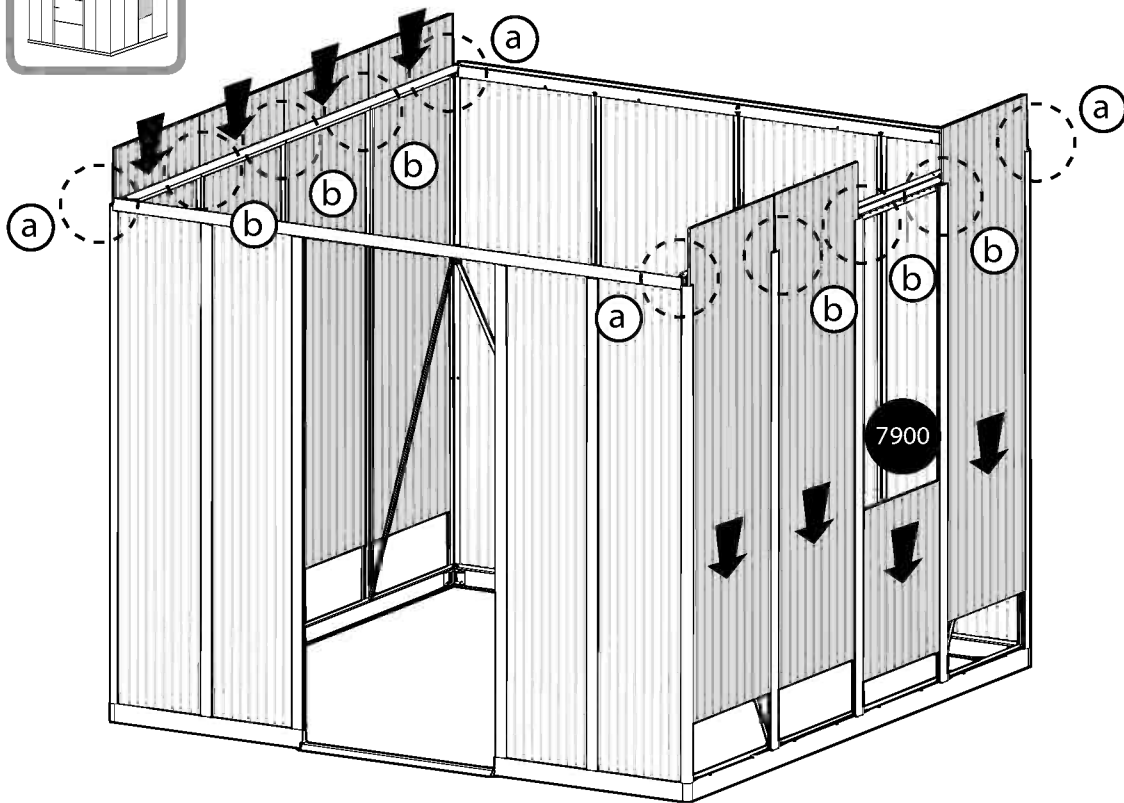
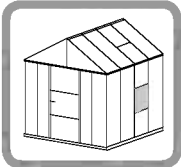
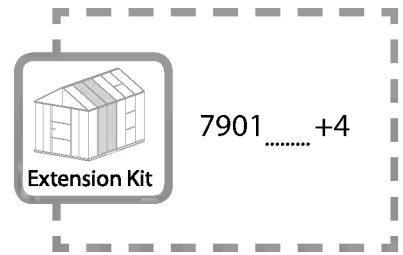
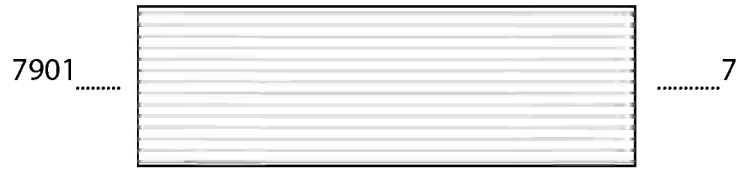
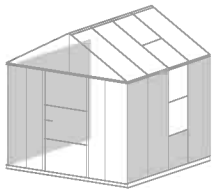

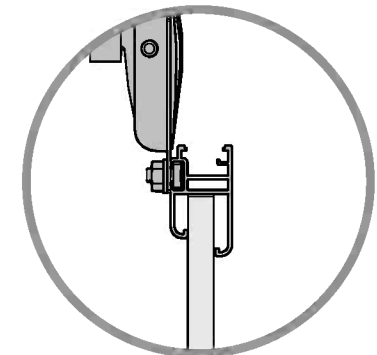
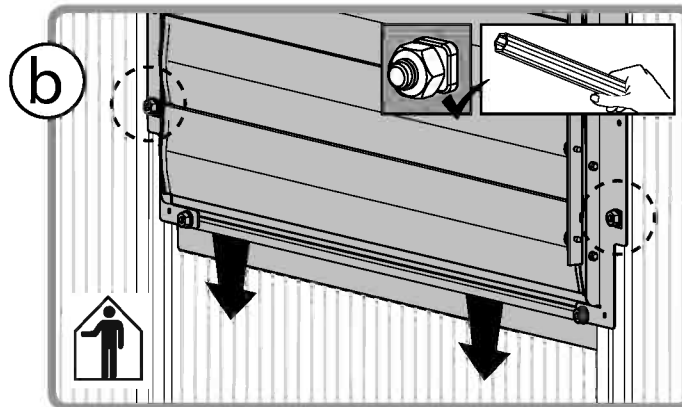
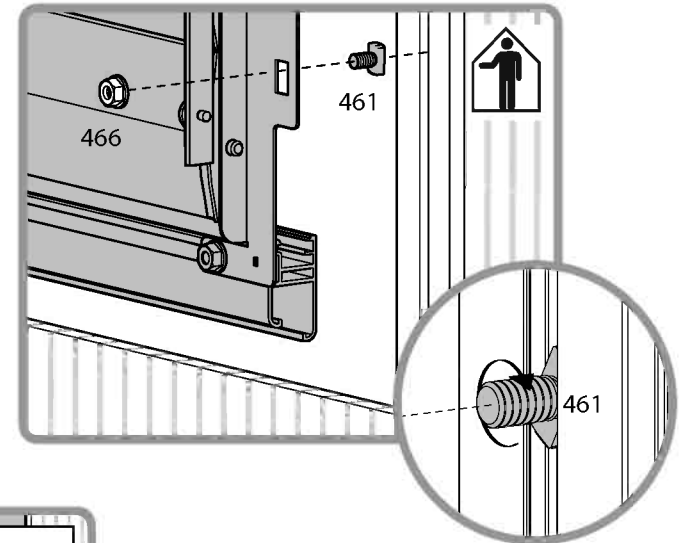
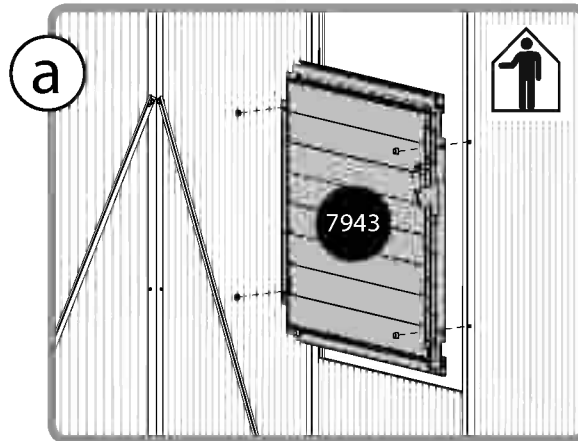
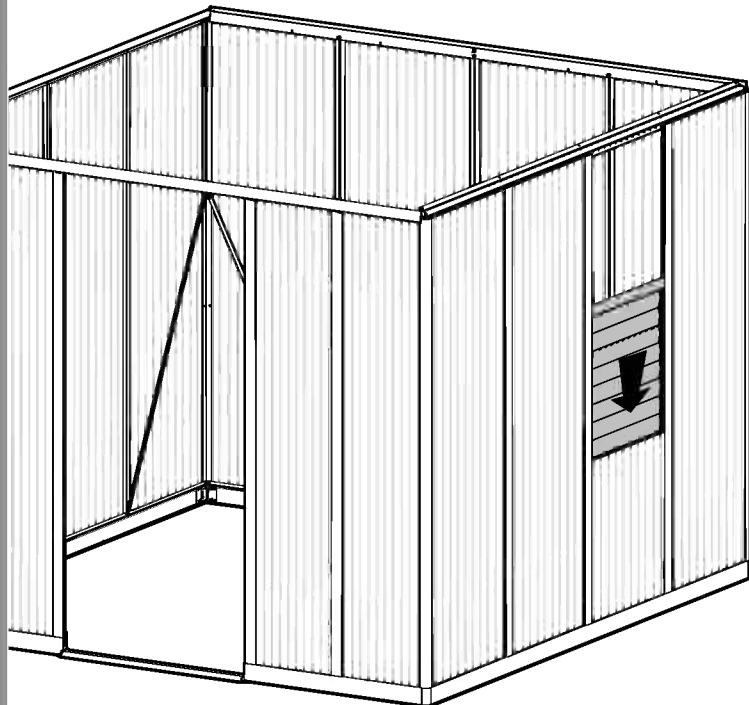
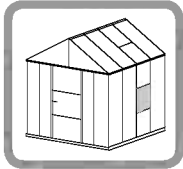
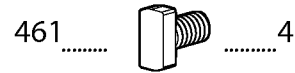
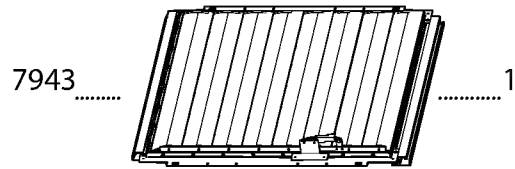
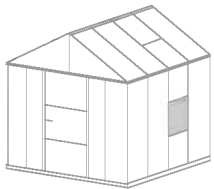

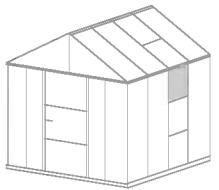

7900 .....  
59 x 62 cm  
23"x24"

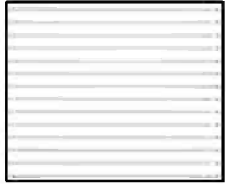

.....1

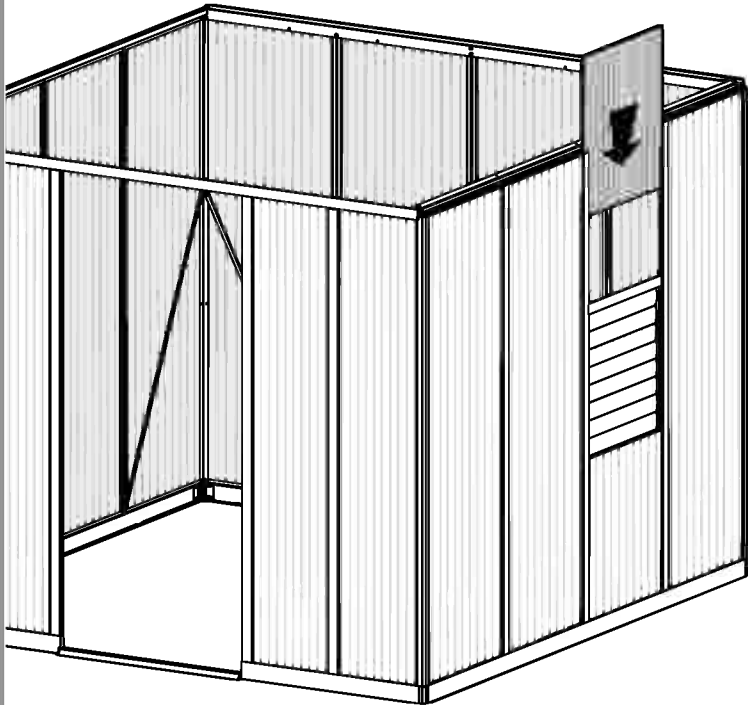
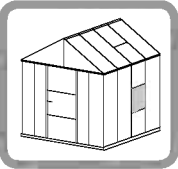

a

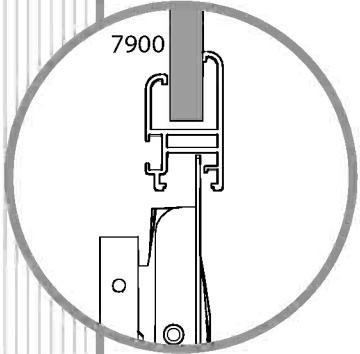
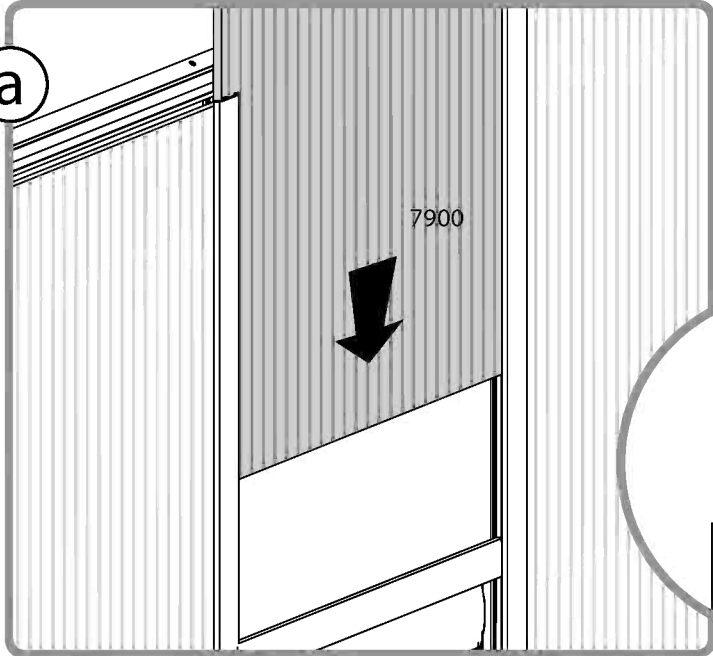

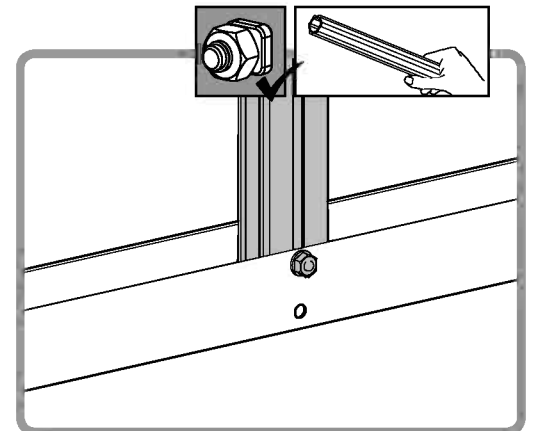
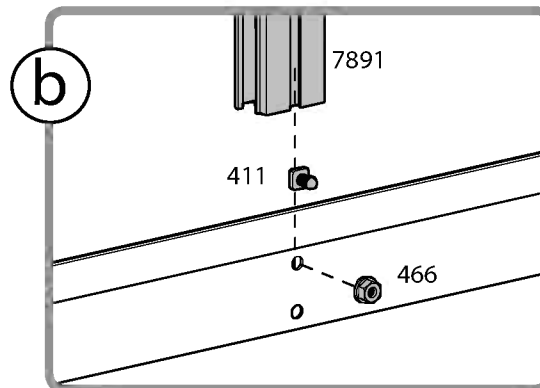
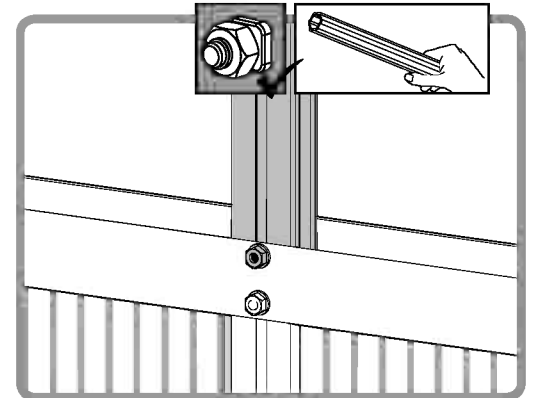
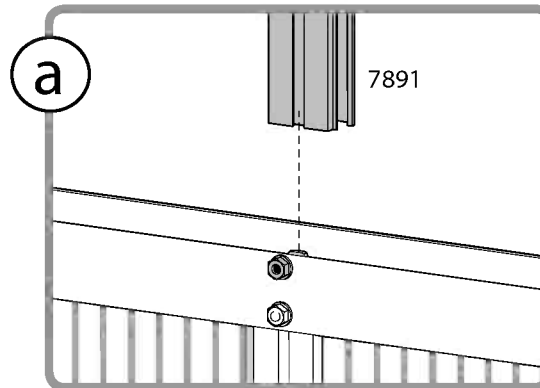
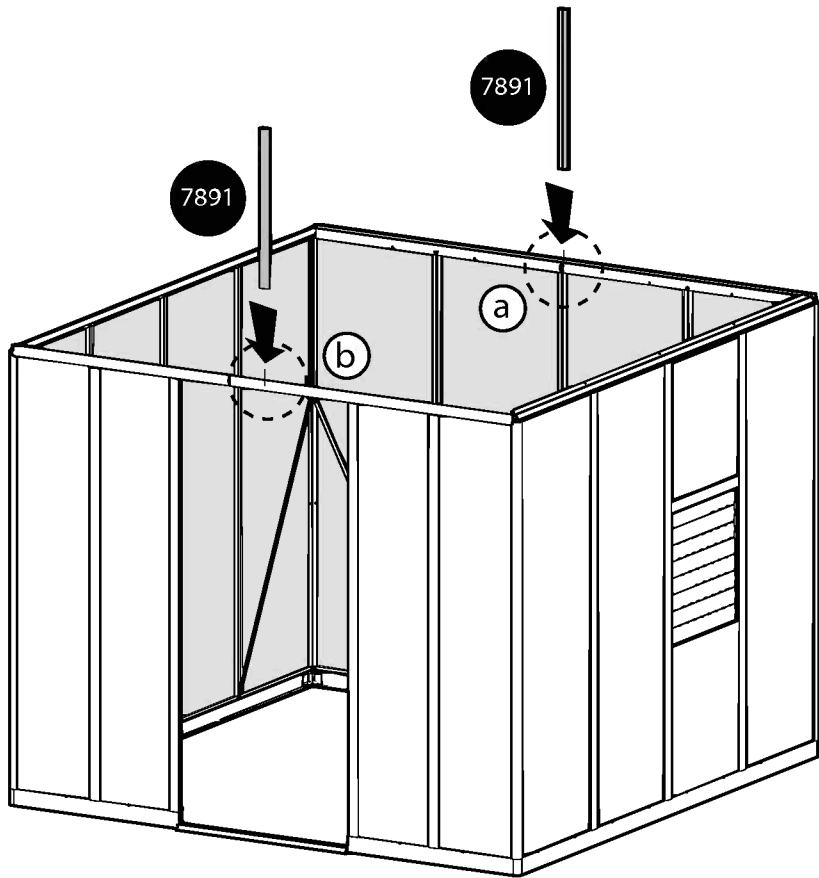
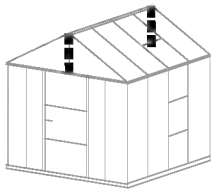

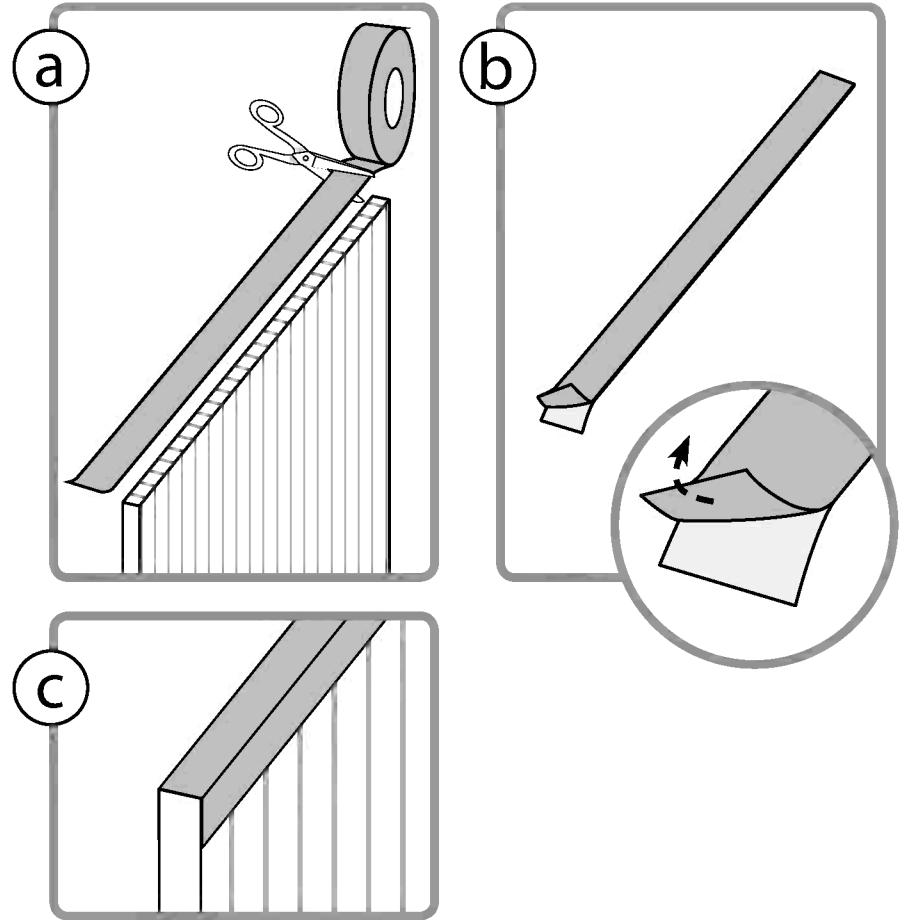
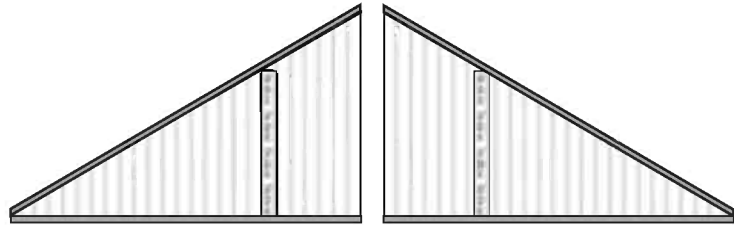
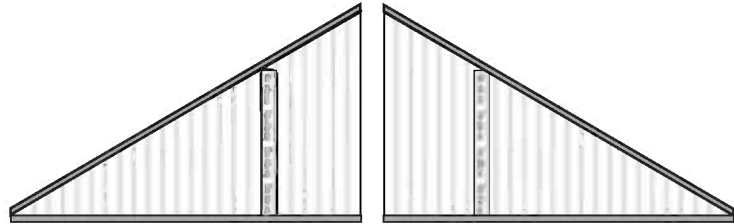
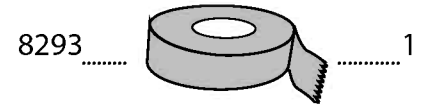
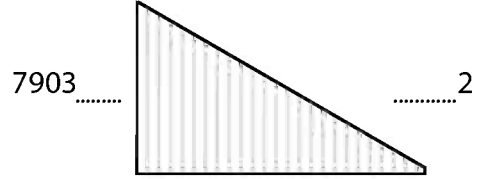
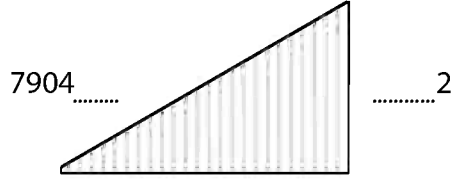
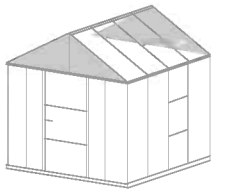

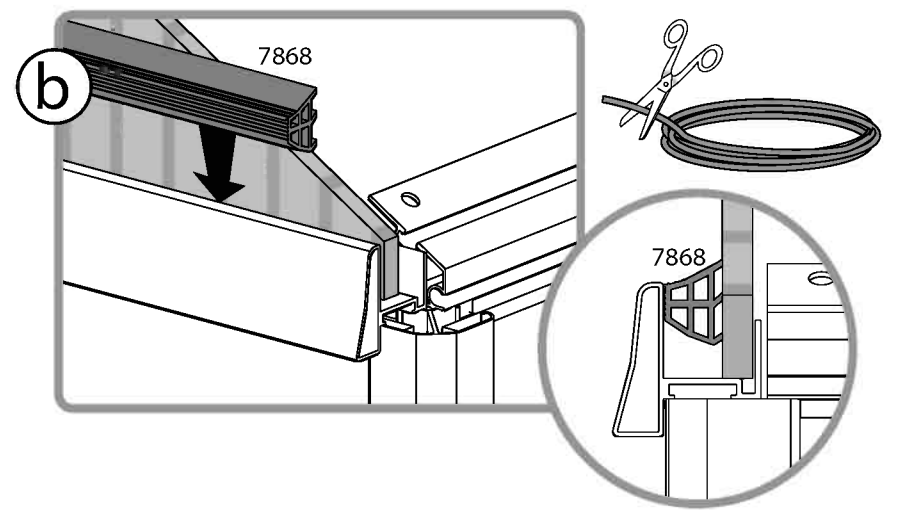
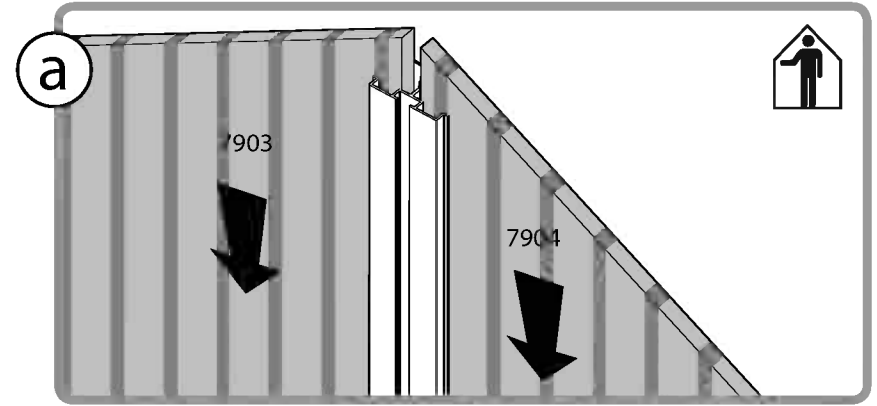
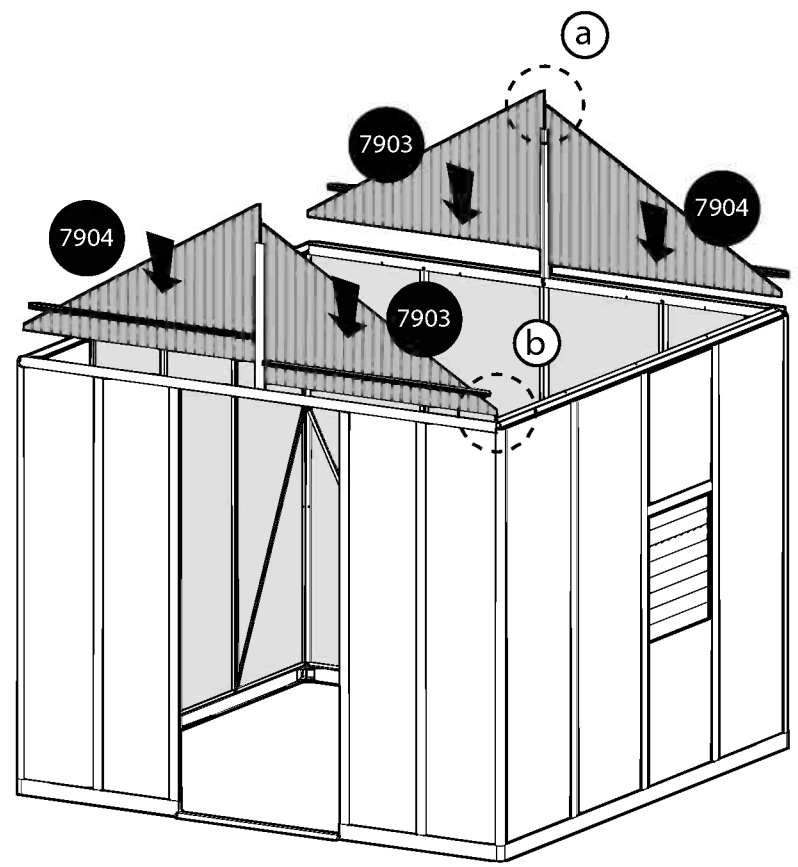
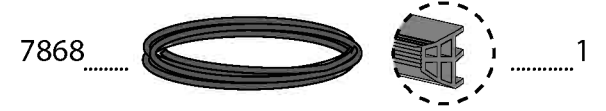
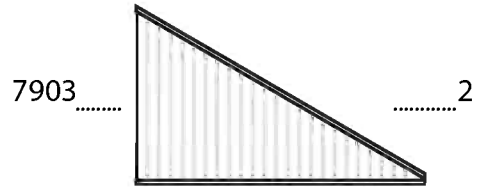
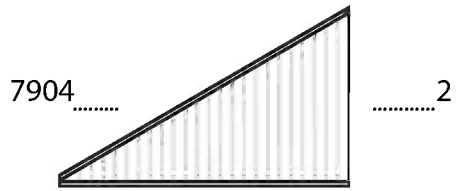
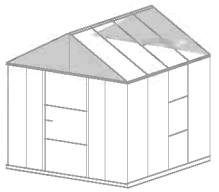



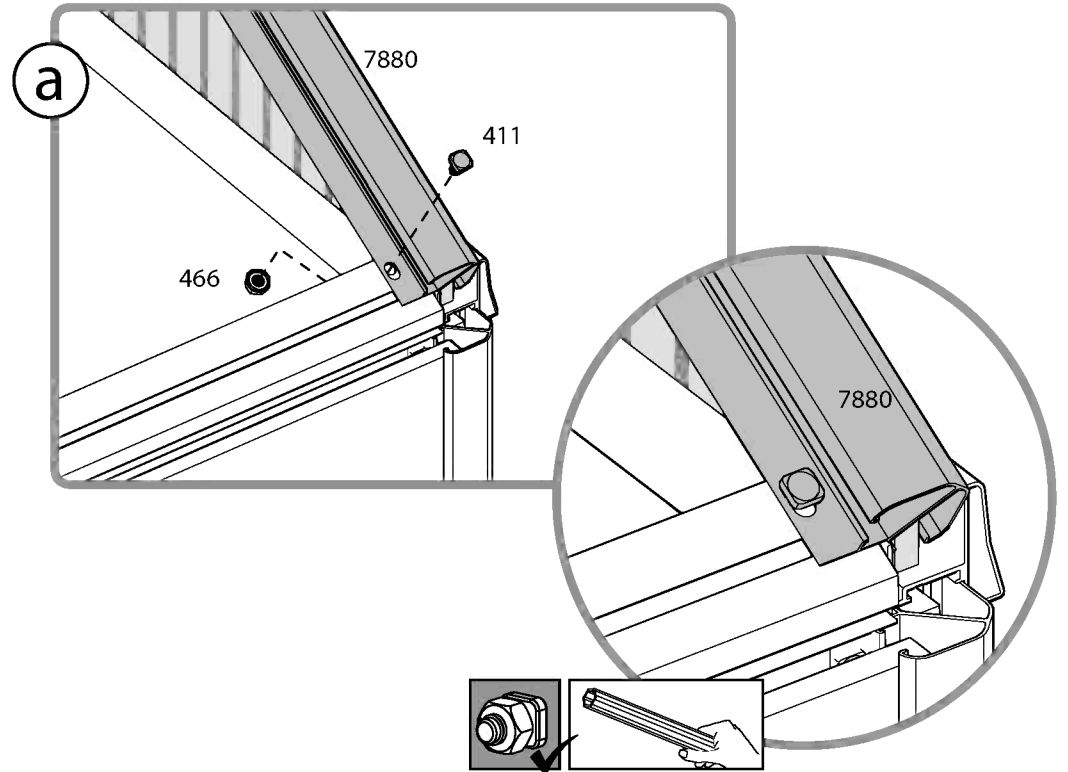
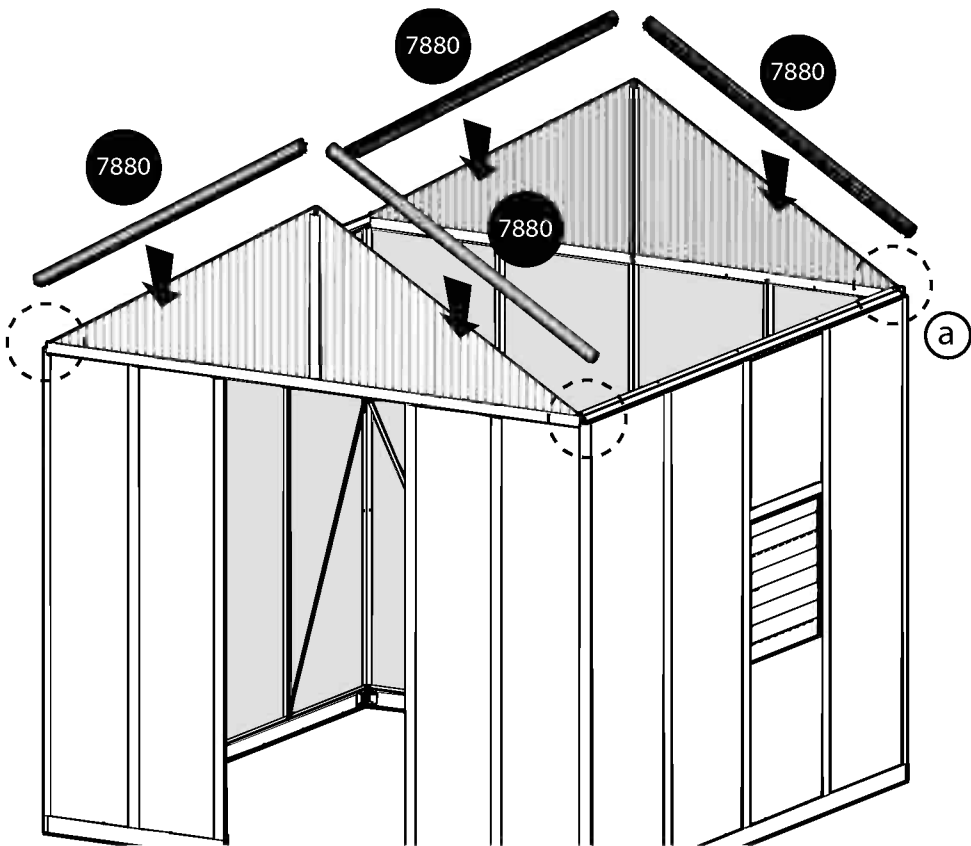
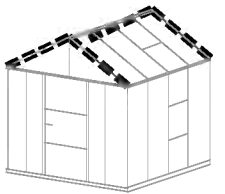

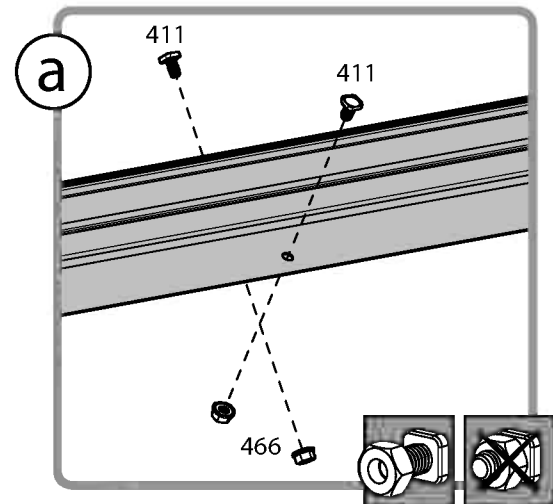
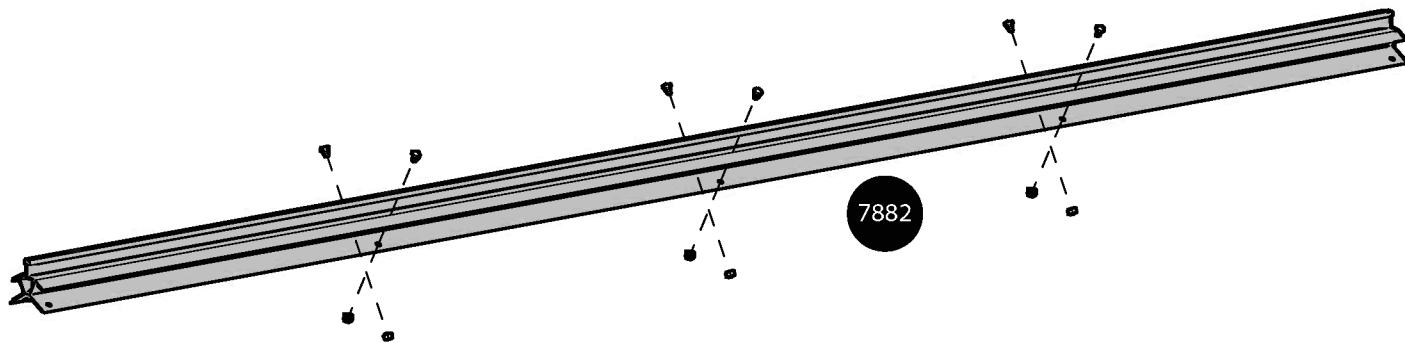
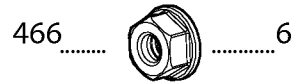
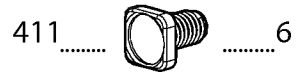
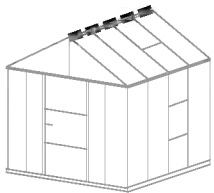

# 29 For Extension Kit Only

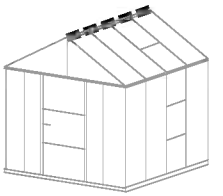

- |            |  |         |            |  |         |           |  |          |
|------------|--|---------|------------|--|---------|-----------|--|----------|
| 7926 ..... |  | ..... 1 | 7930 ..... |  | ..... 1 | 411 ..... |  | ..... 12 |
| 7882 ..... |  | ..... 1 | 7931 ..... |  | ..... 1 | 466 ..... |  | ..... 12 |

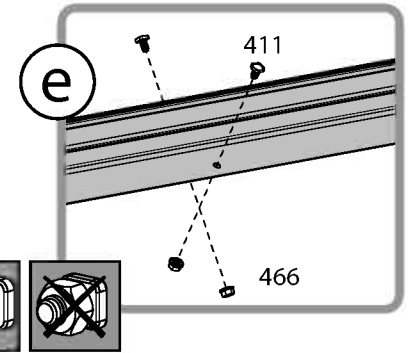
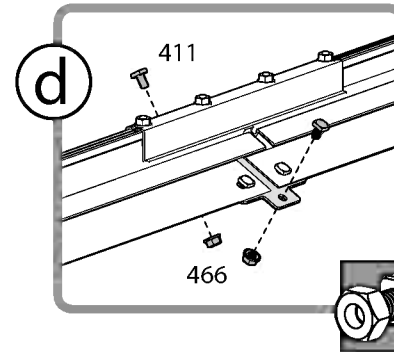
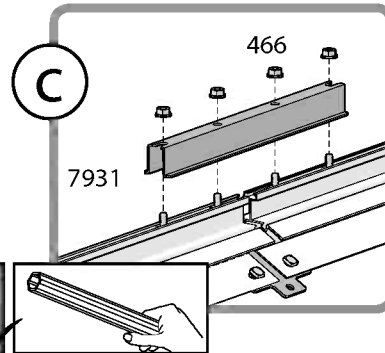
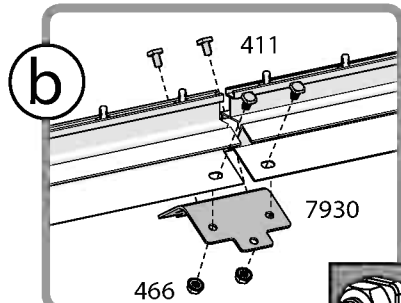
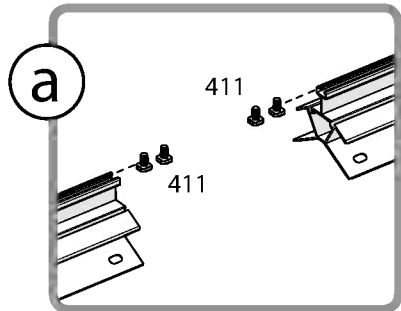
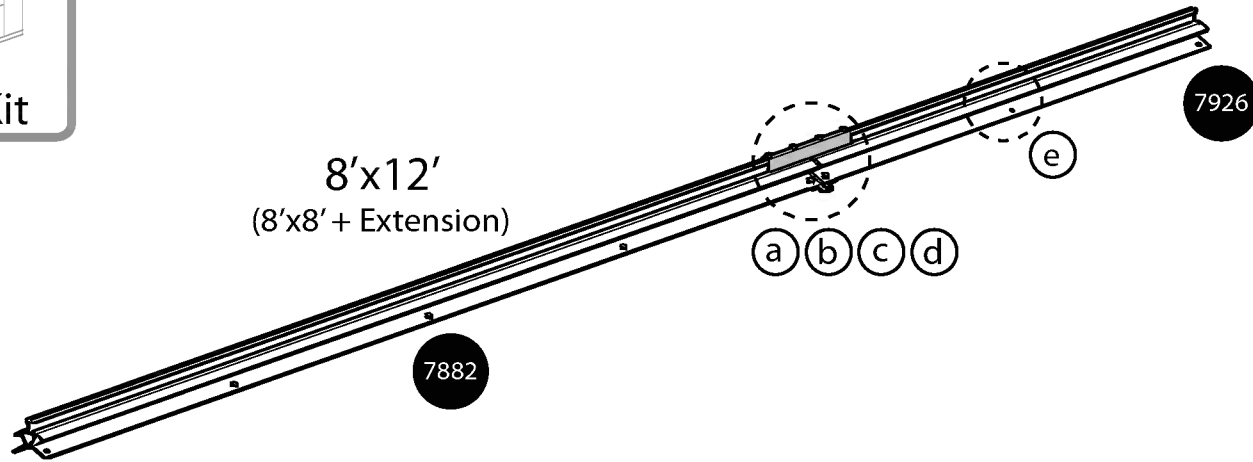

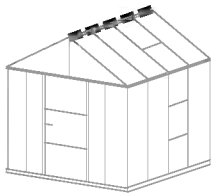

7882

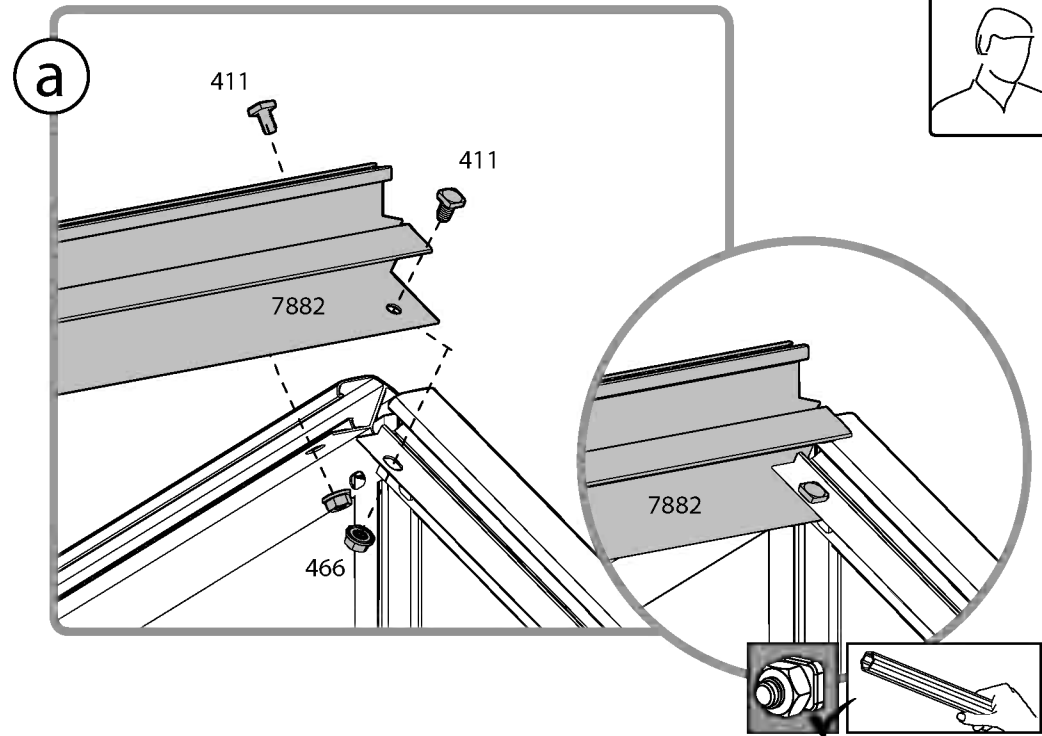
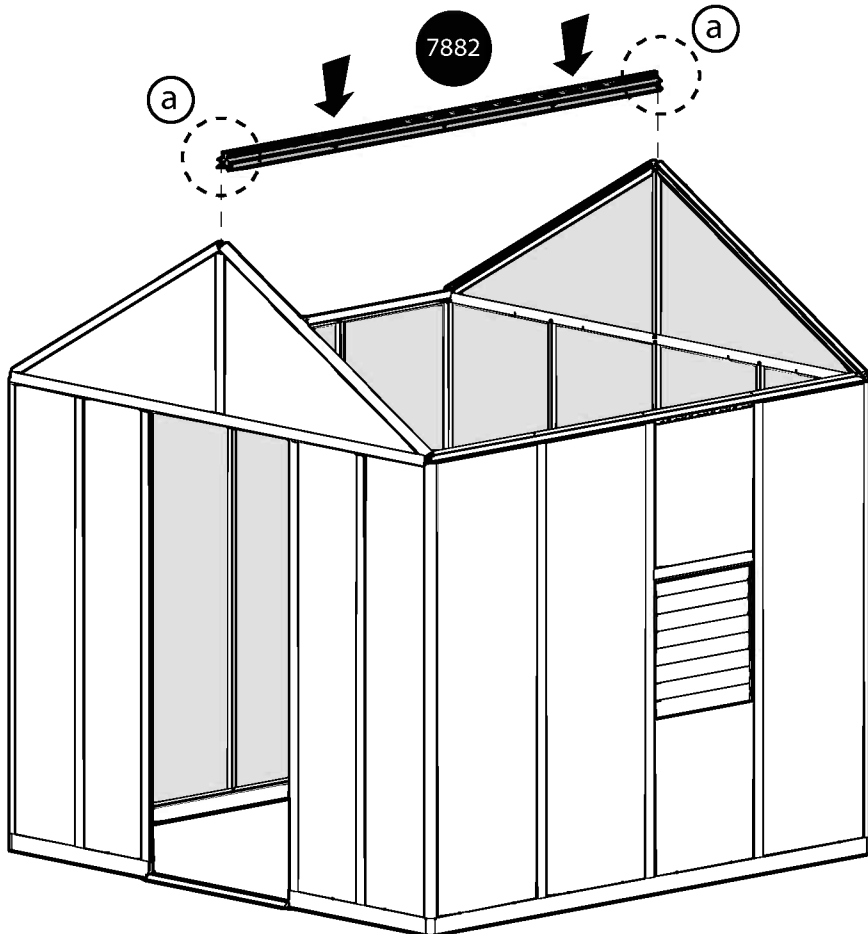

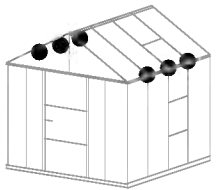

411..........6

466..........6



411.....+4

466.....+4

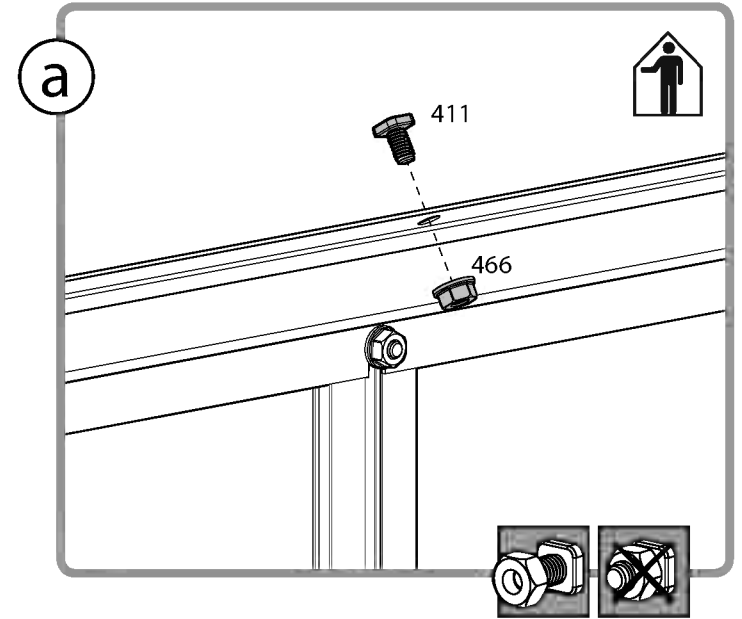
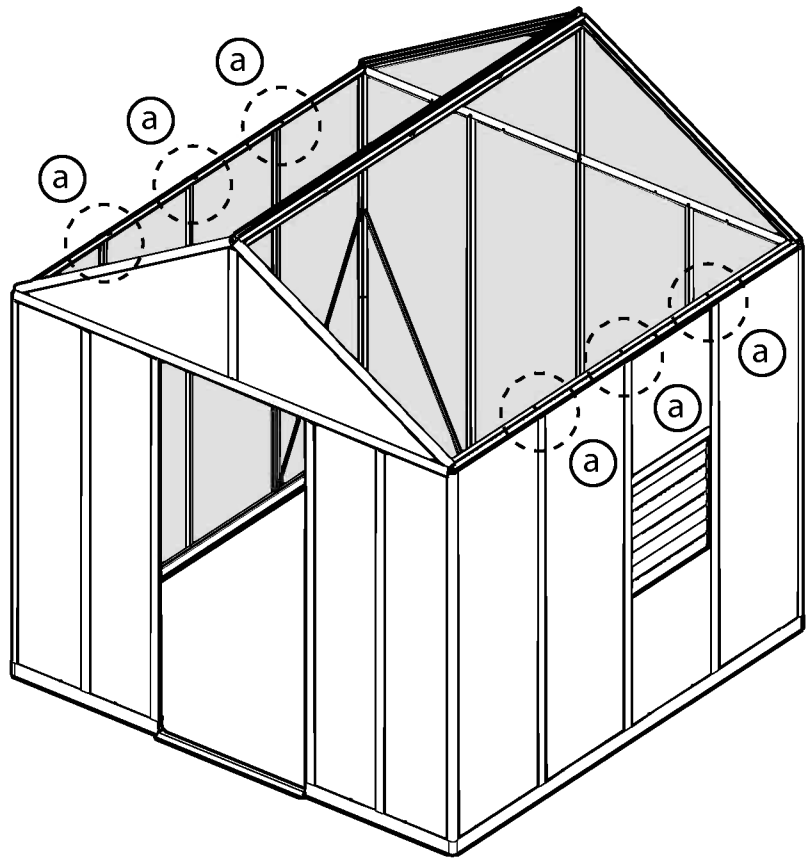

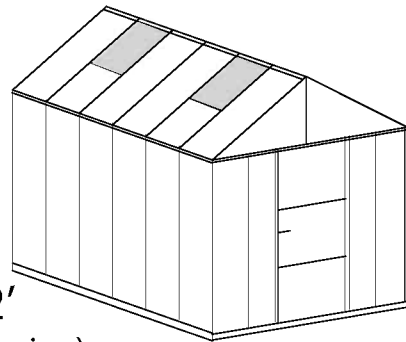
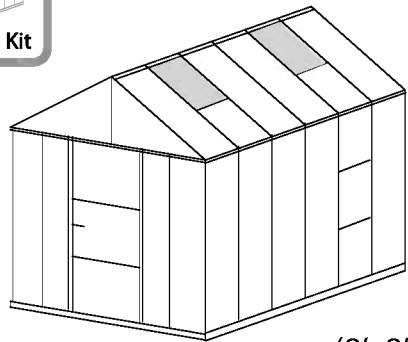
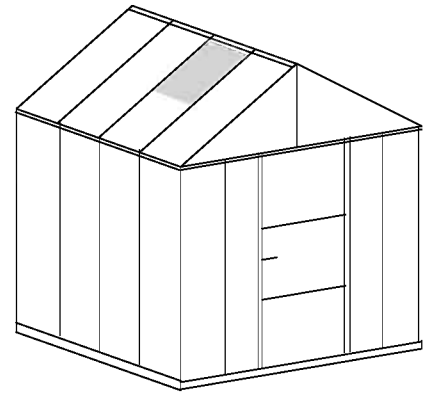
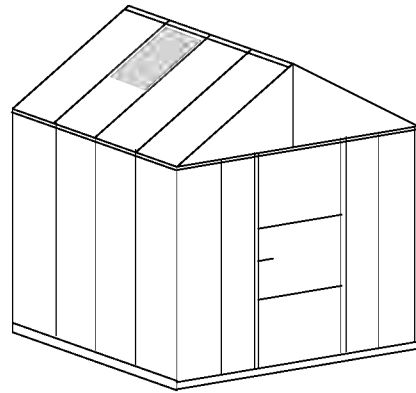
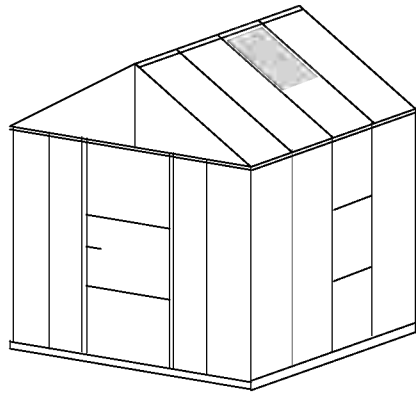
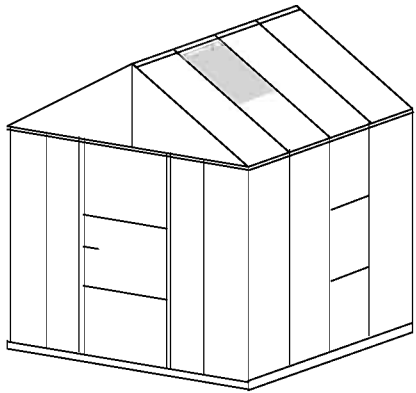
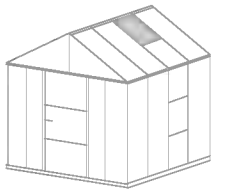

8'x12'  
(8'x8' + Extension)

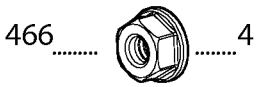
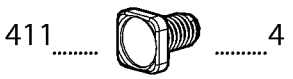
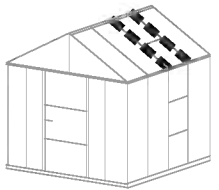

 Extension Kit

7885.....	+2
411.....	+4
466.....	+4

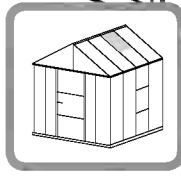
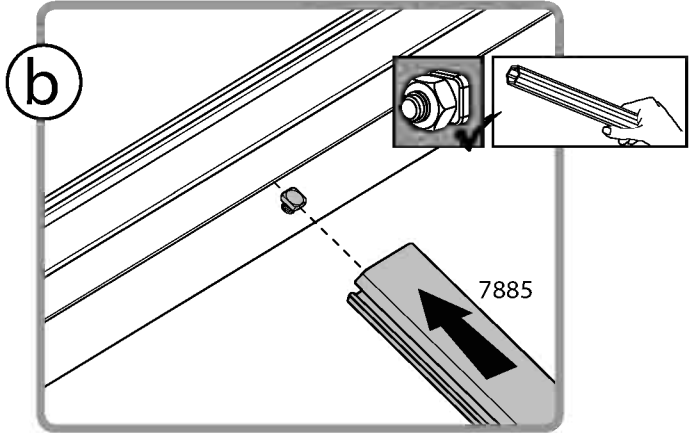
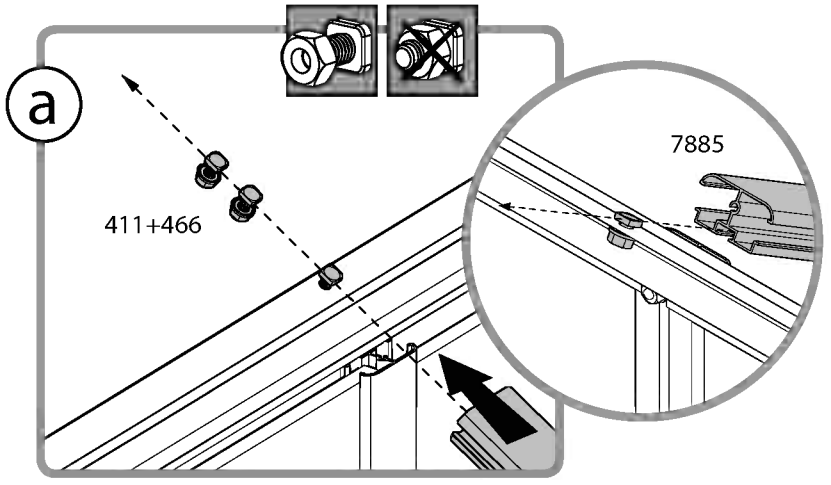
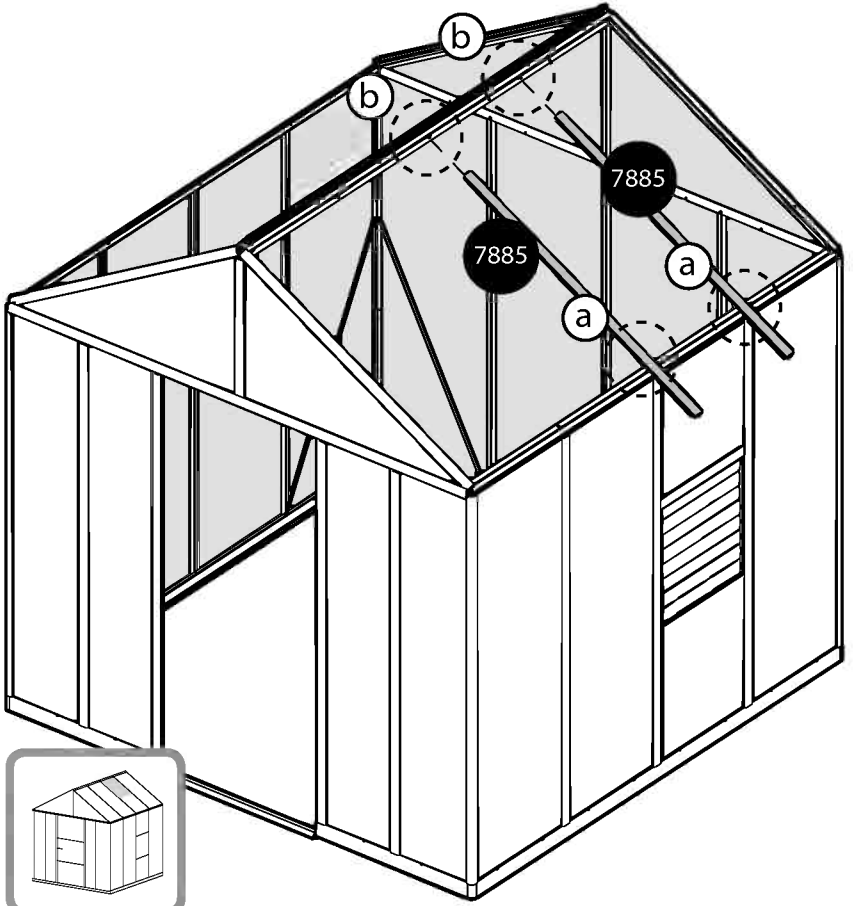

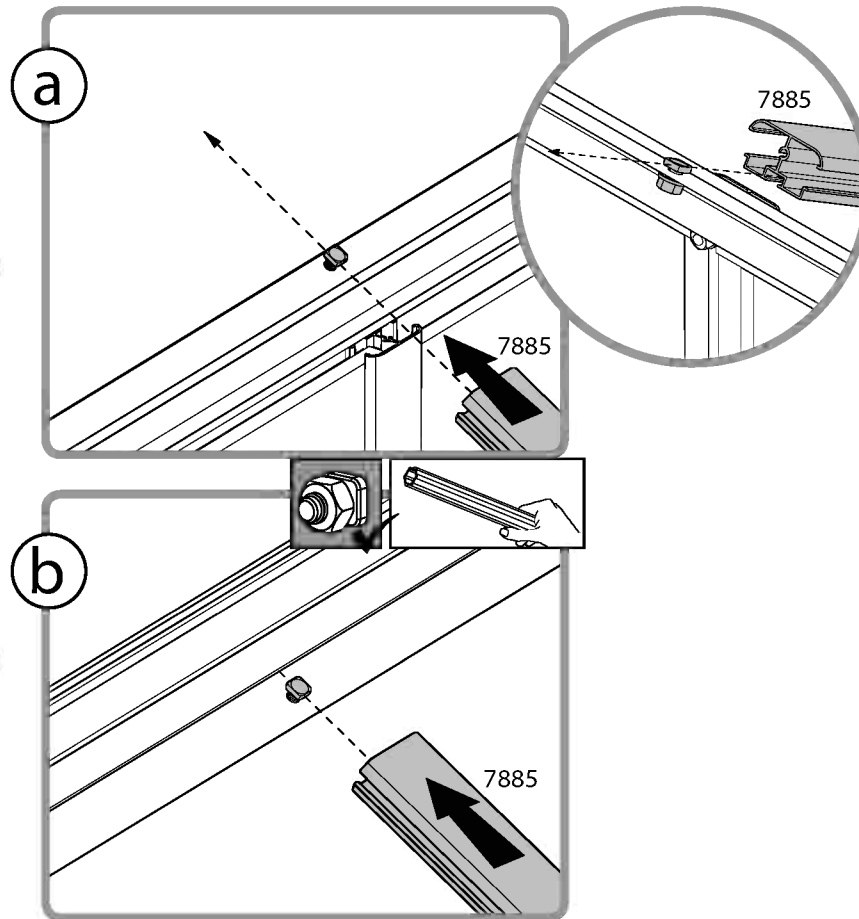
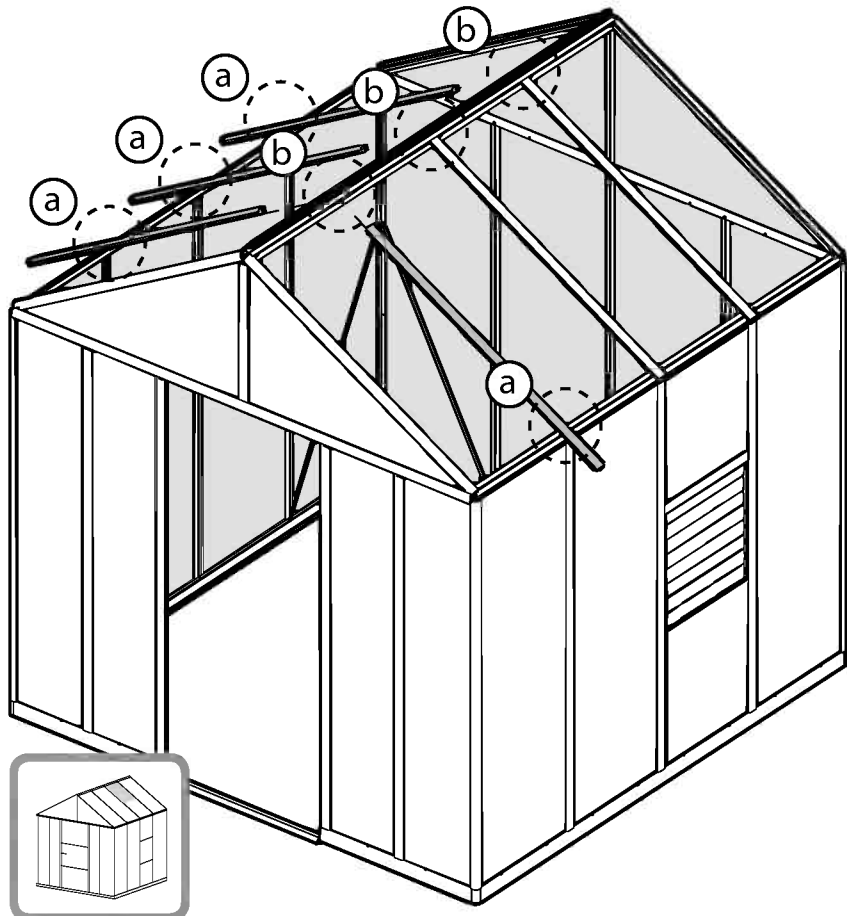
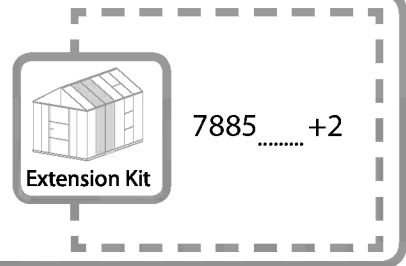
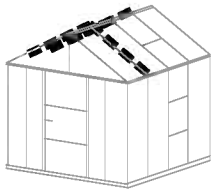



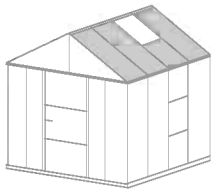

 Extension Kit

7900 ..... +1  
7906 ..... +3

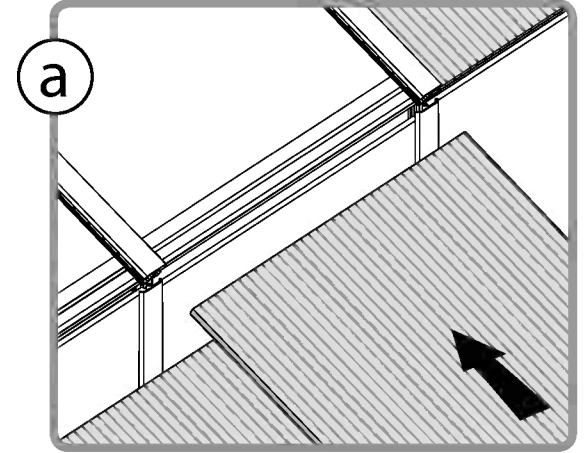
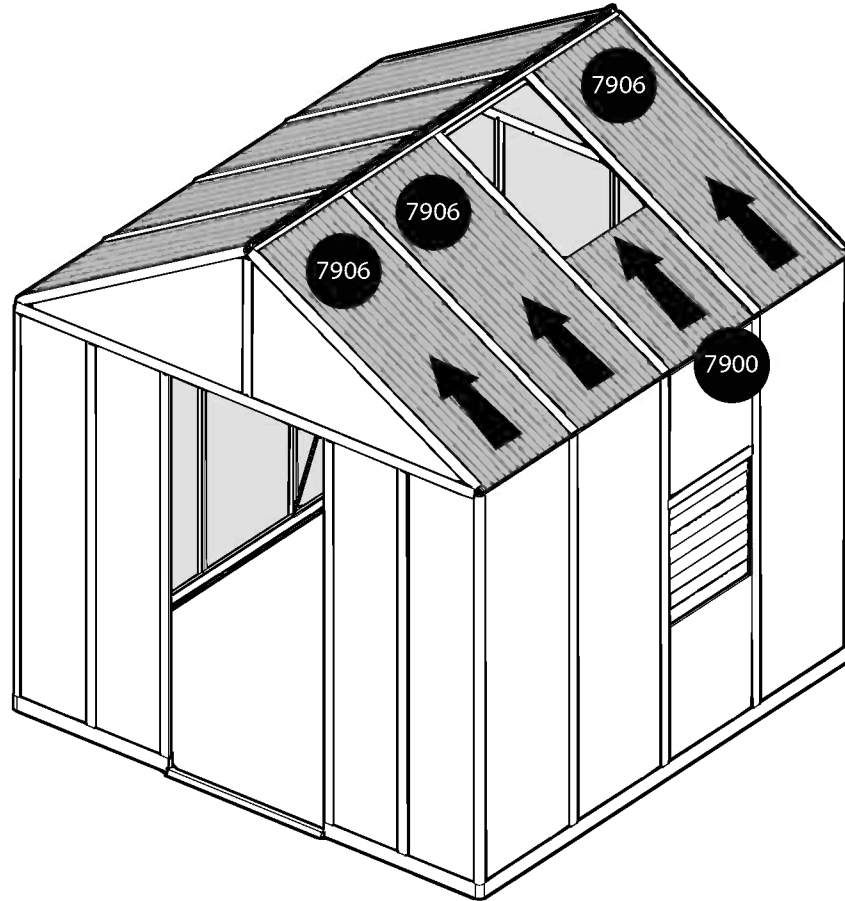
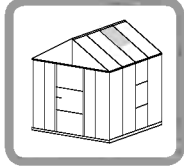

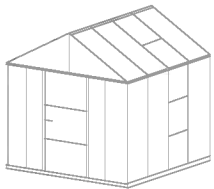

7894 ..... 6

4008 ..... 6



7894 ..... +2  
4008 ..... +2

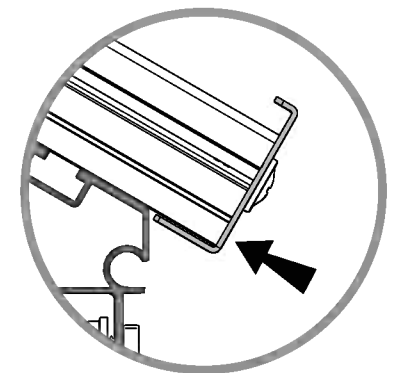
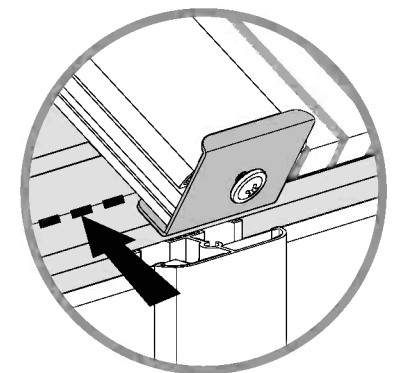
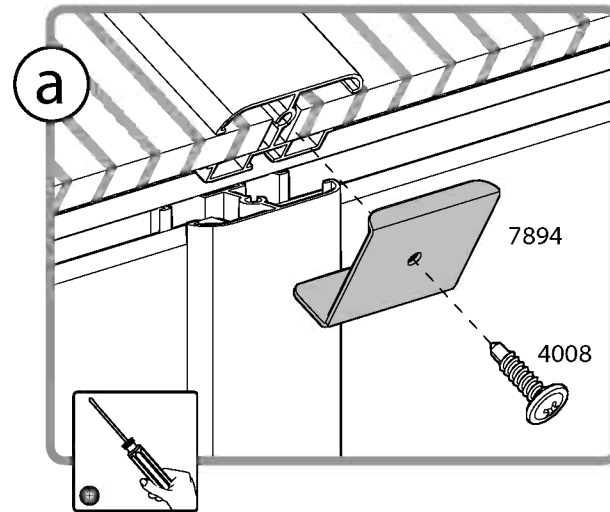
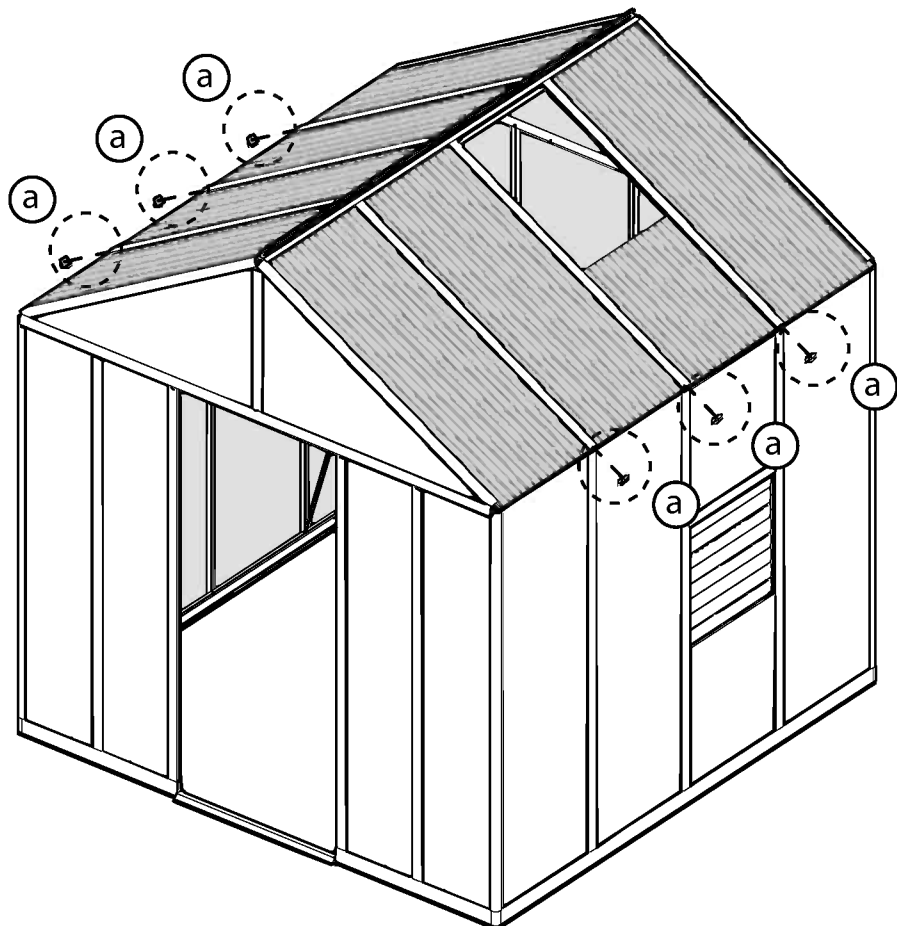

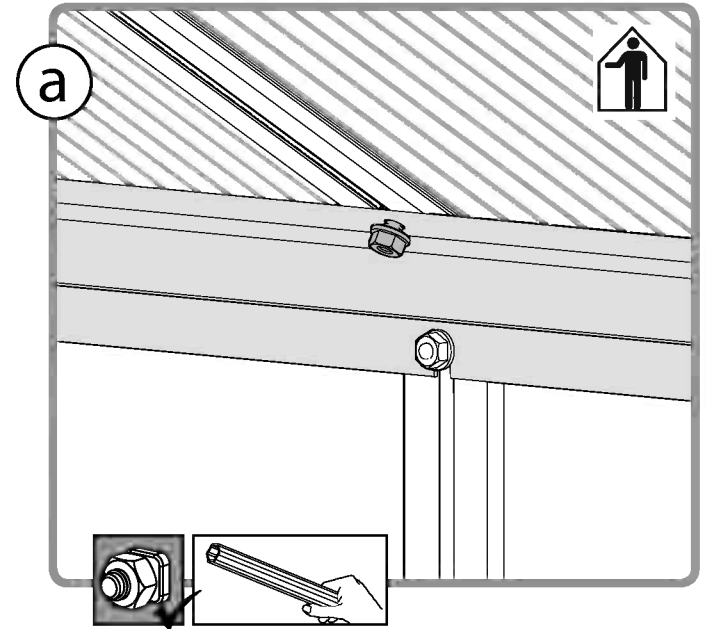
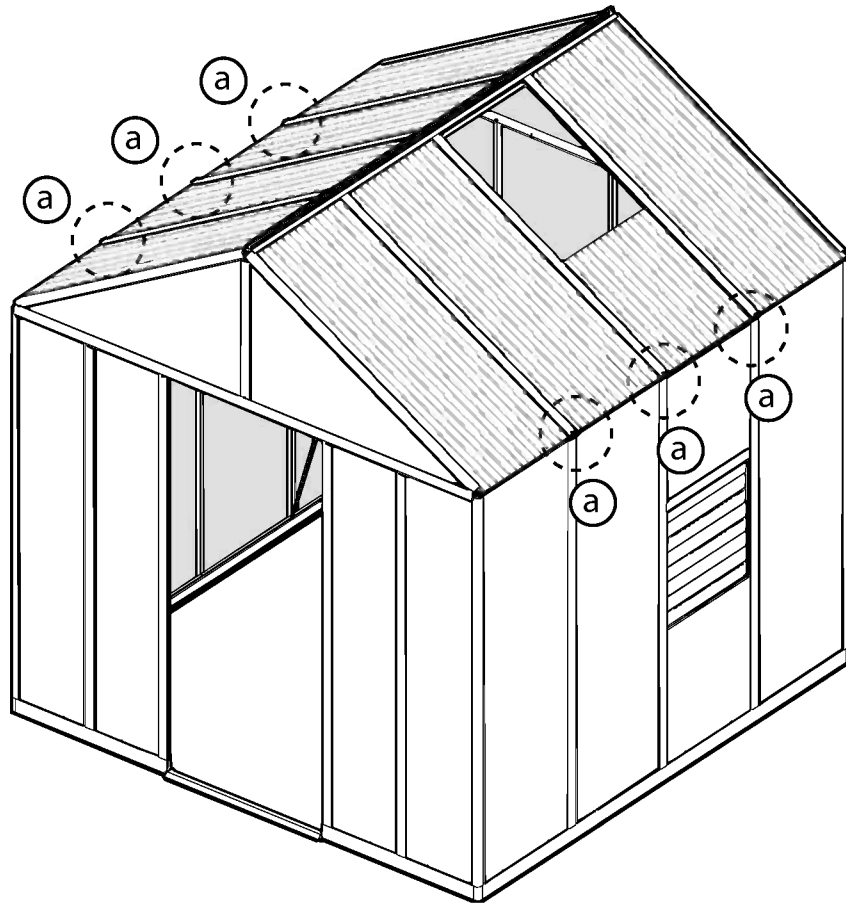
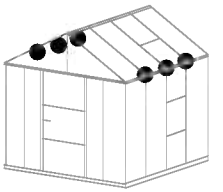

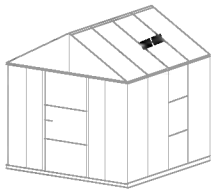

7890.....

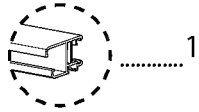

411.....



.....4



7890 ..... +1

411 ..... +4

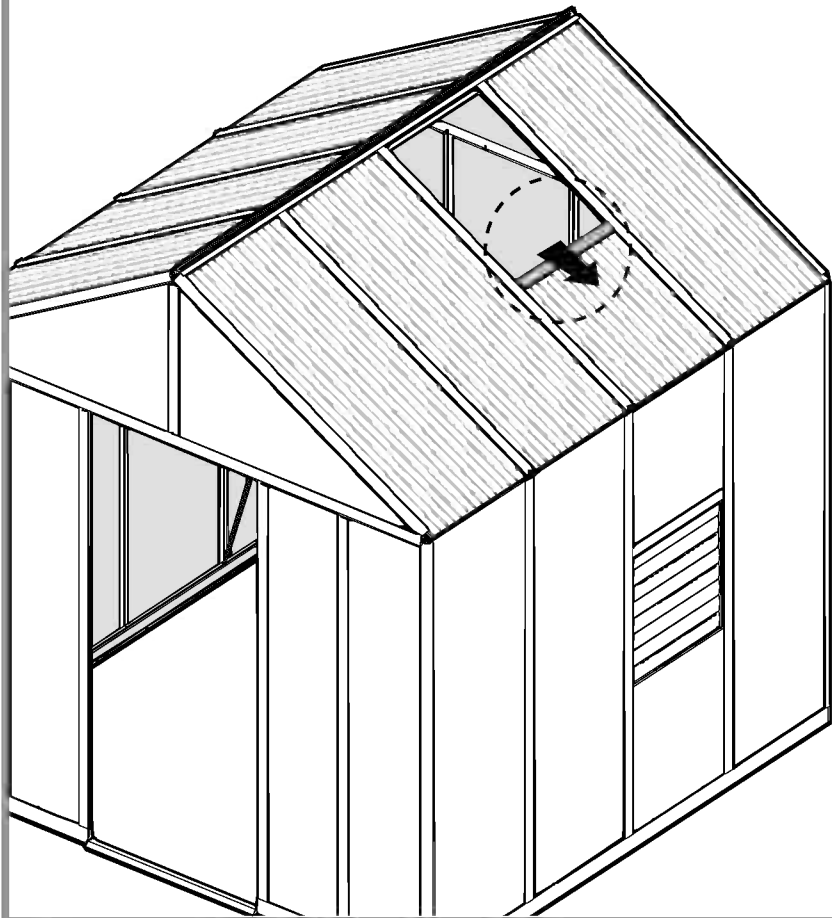

a

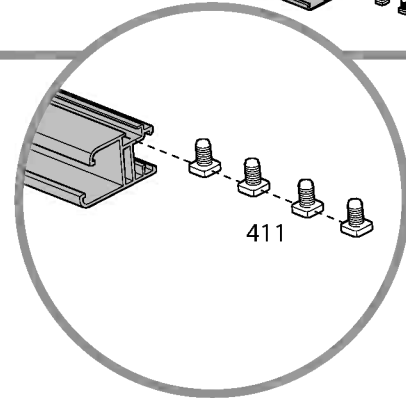
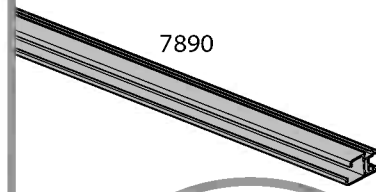

b

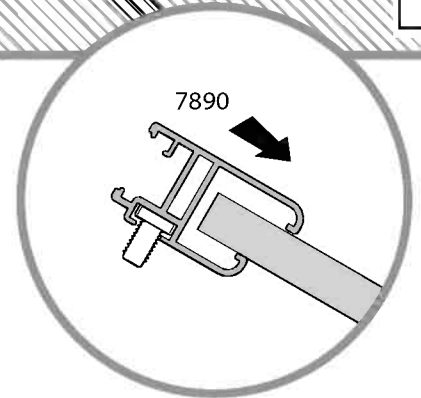
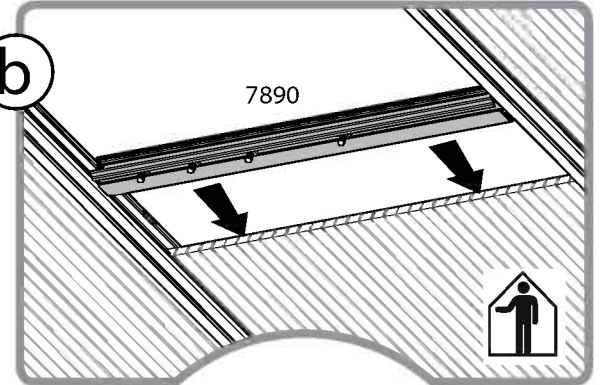

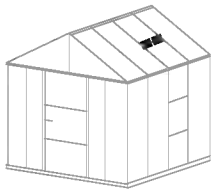

7898 .....

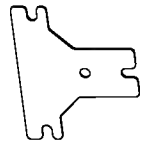

.....2

466 .....



.....4



7898 ..... +2

466 ..... +4

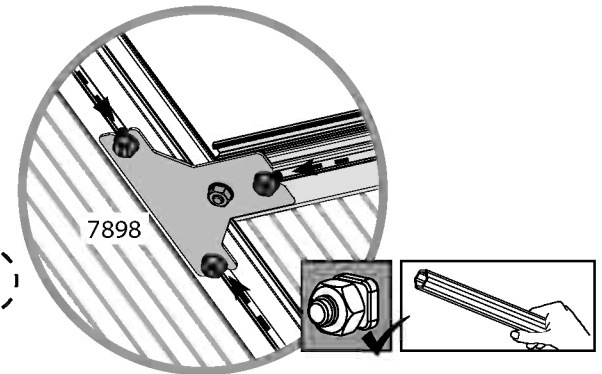
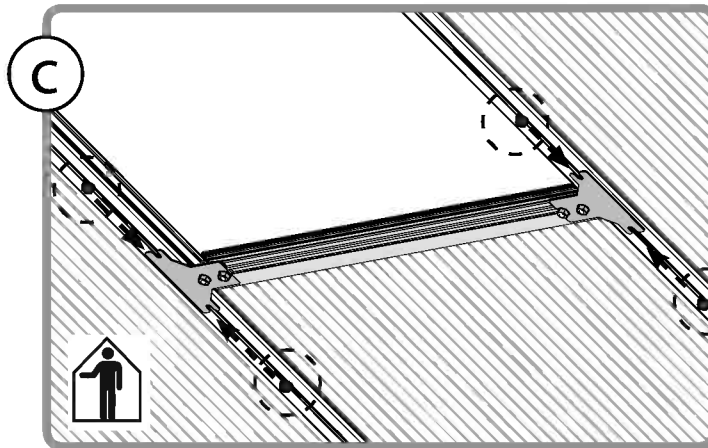
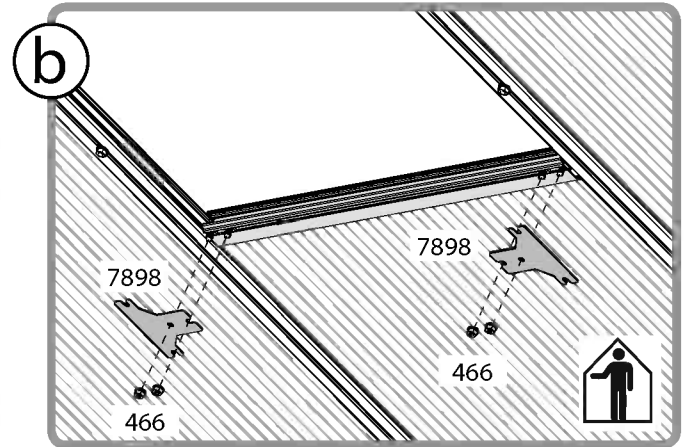
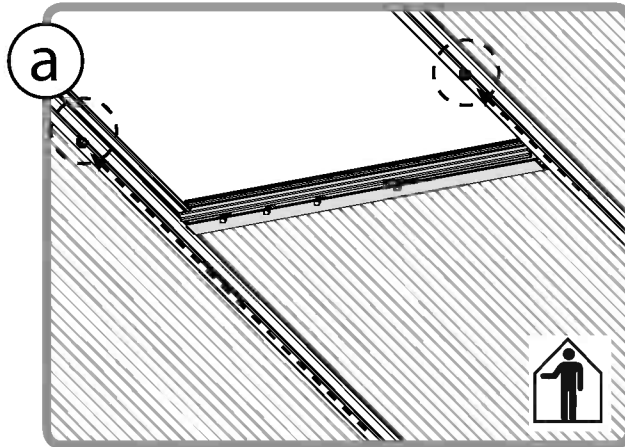
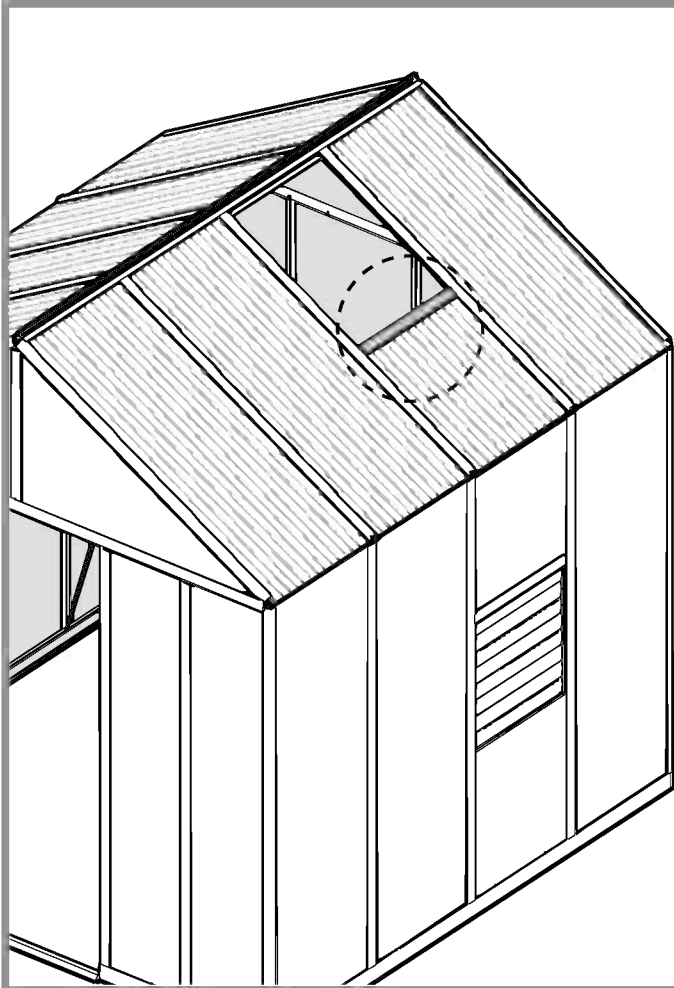

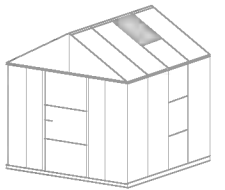

7907 ..... 1

7878 ..... 2

7914 ..... 2

989 ..... 1

991 ..... 1

4008 ..... 4

**a**

7914

7914

7878

7878

7907

7878

7914

x2

**b**

989

4008

989

991

4008

991

x2

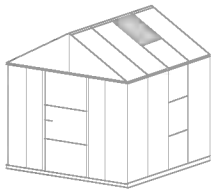

7009 ..... 2

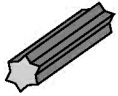

7009 ..... +2

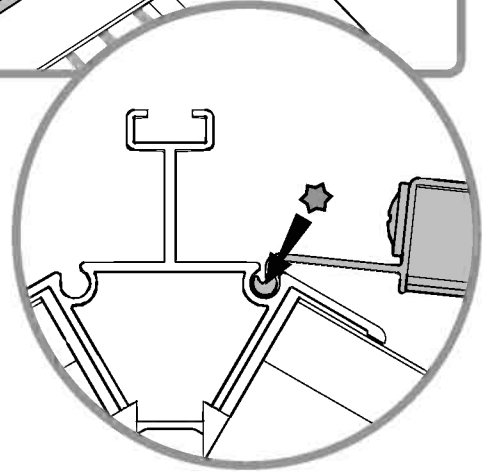
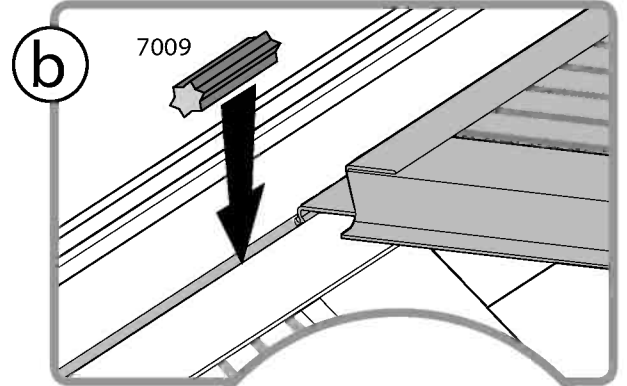
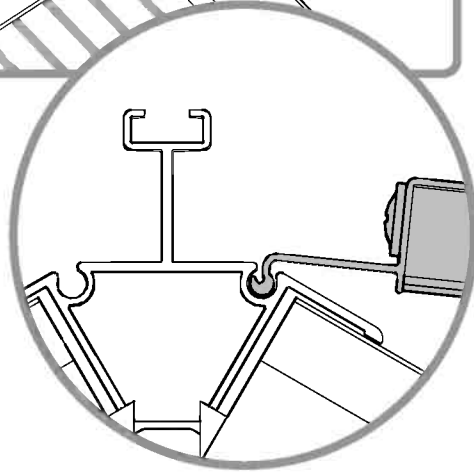
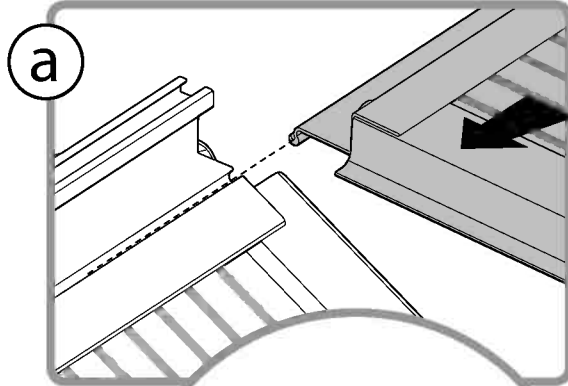
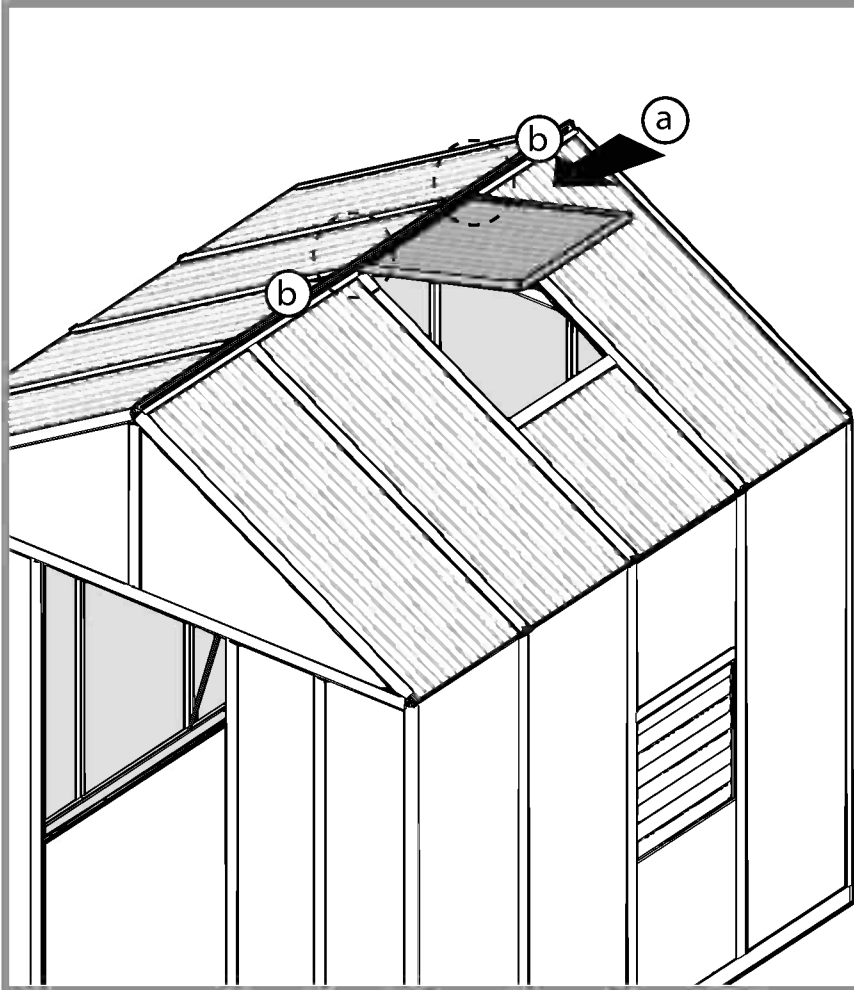

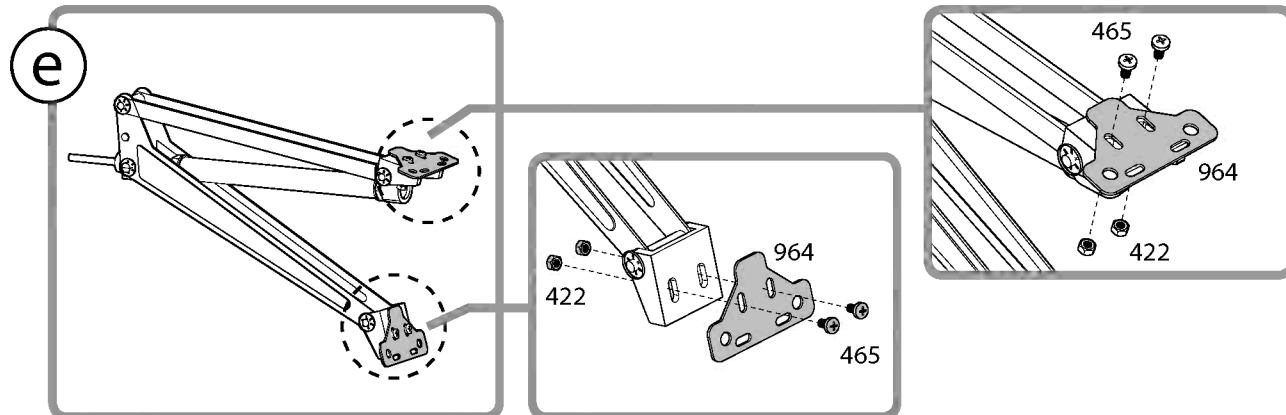
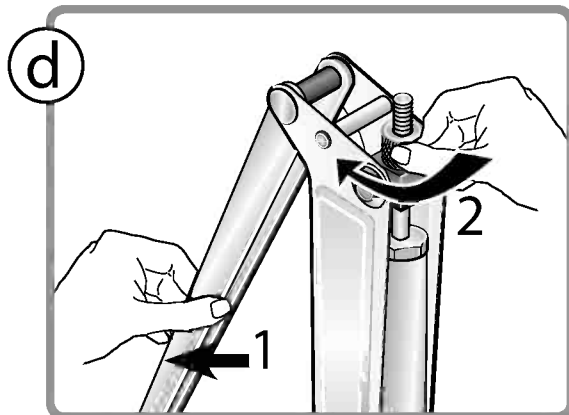
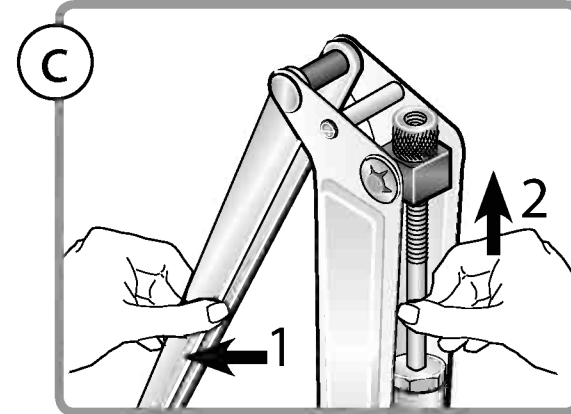
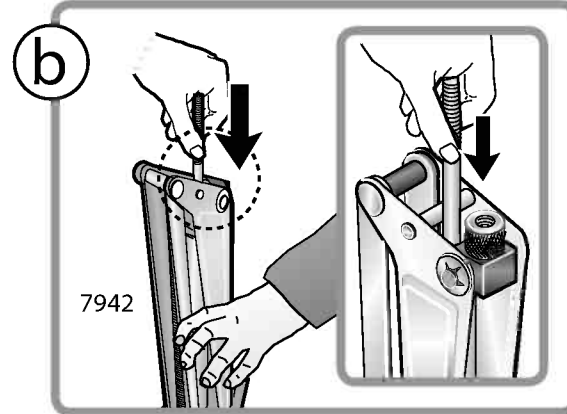
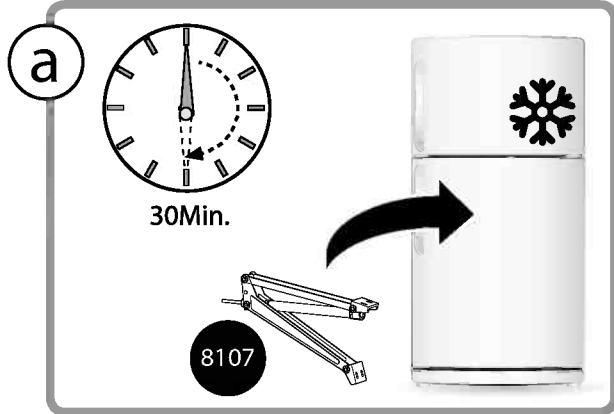
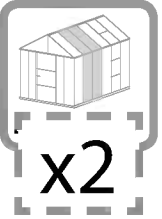
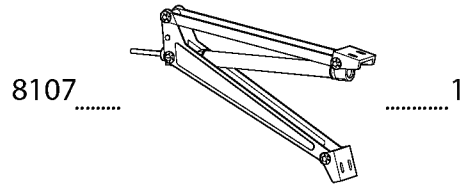
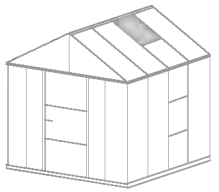



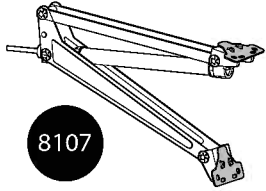
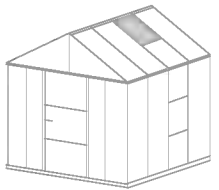

8107

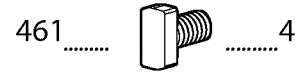

461

4



466

4



x2

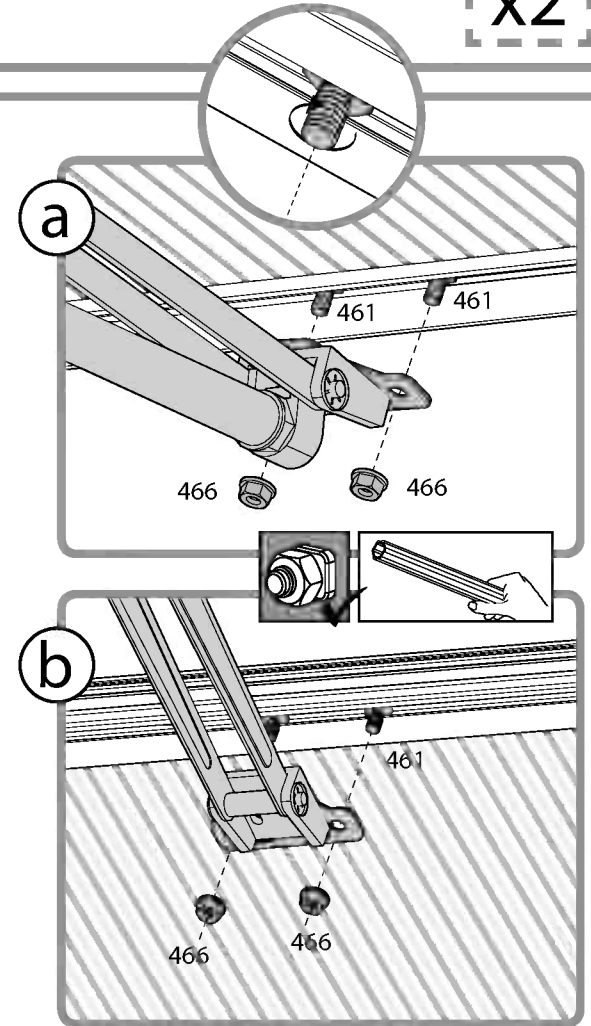
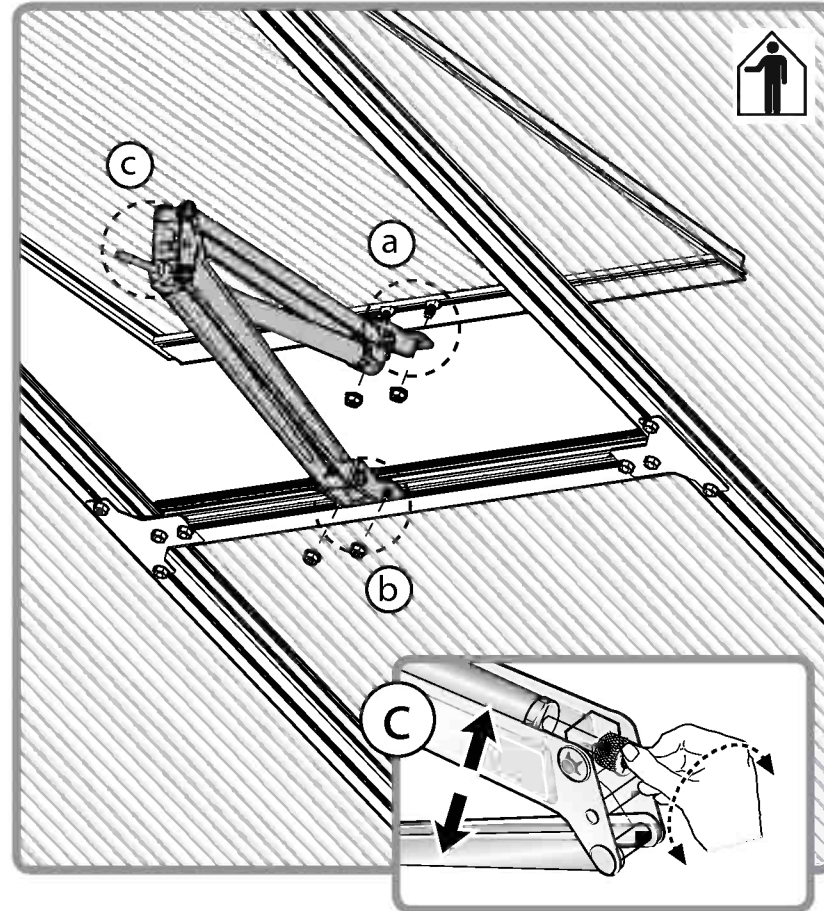
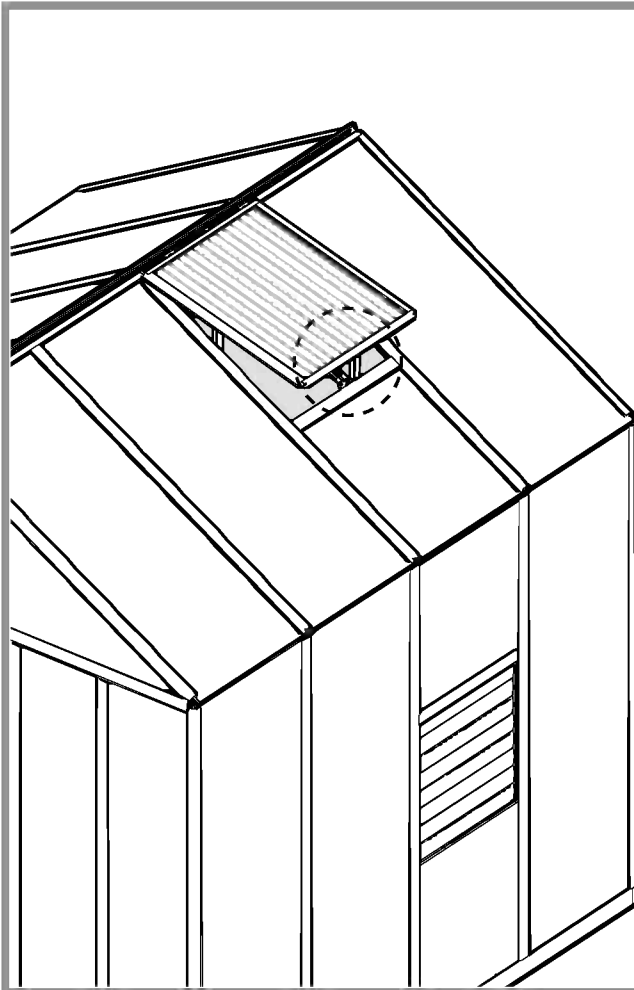

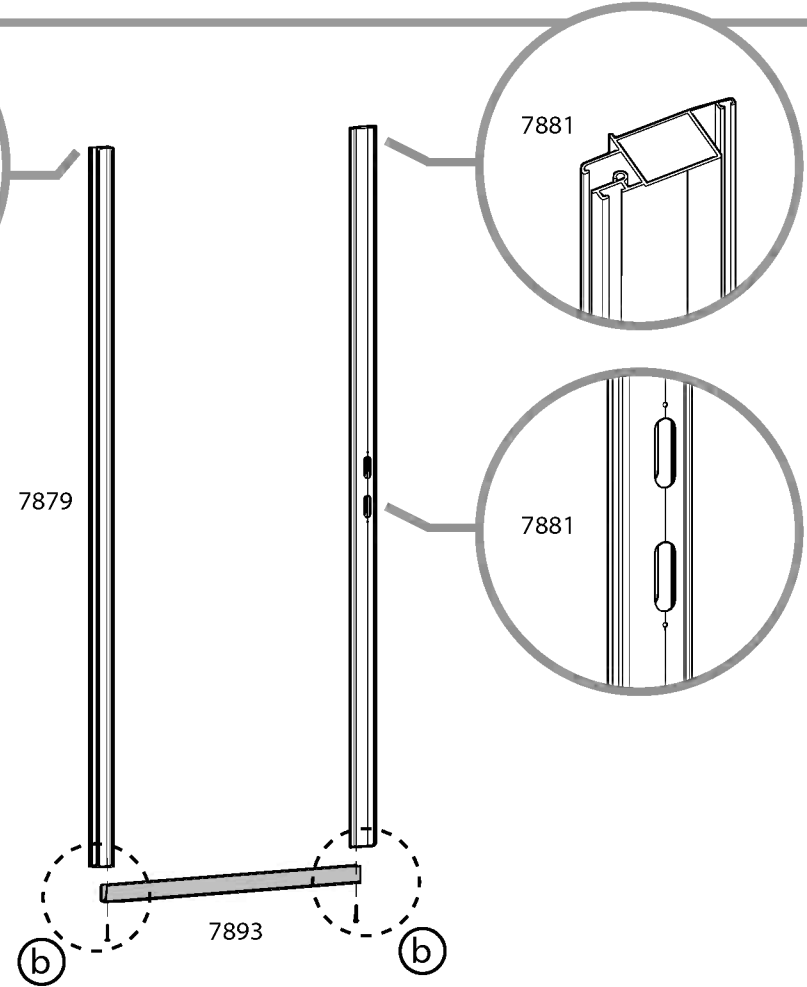
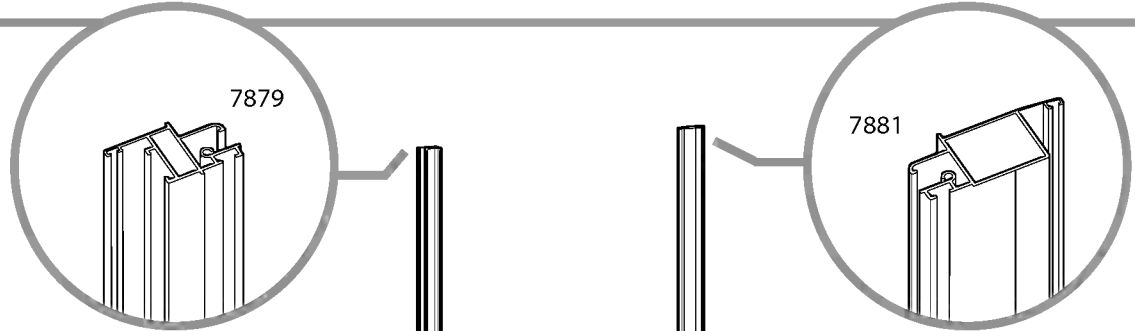
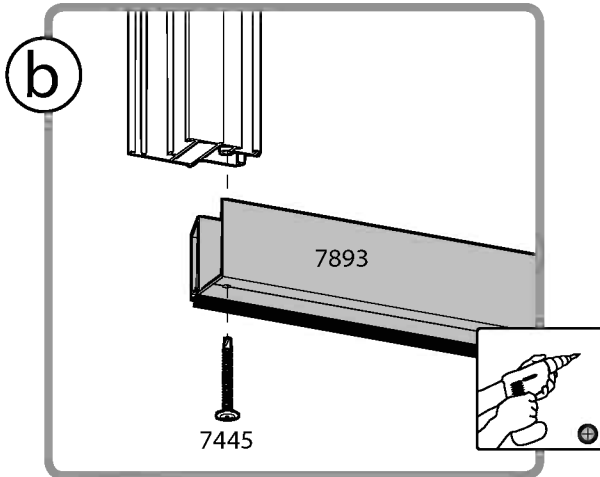
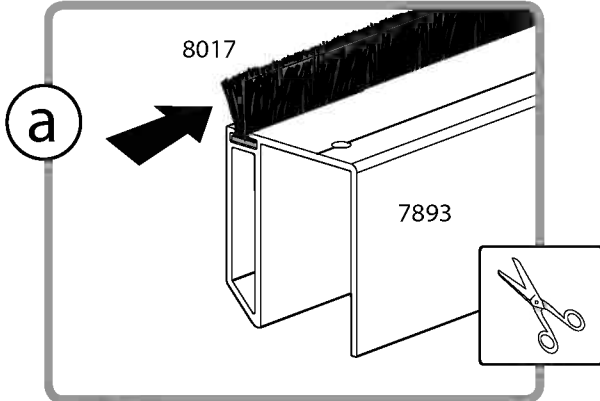
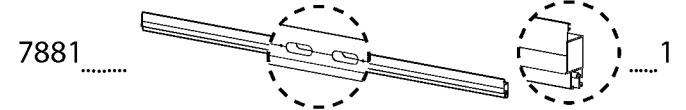
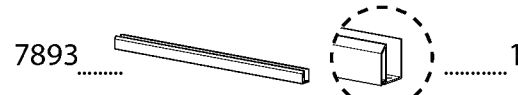
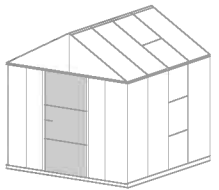

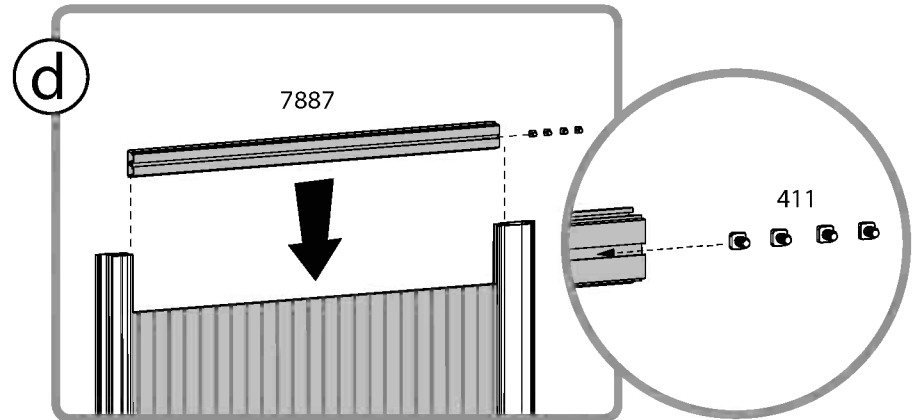
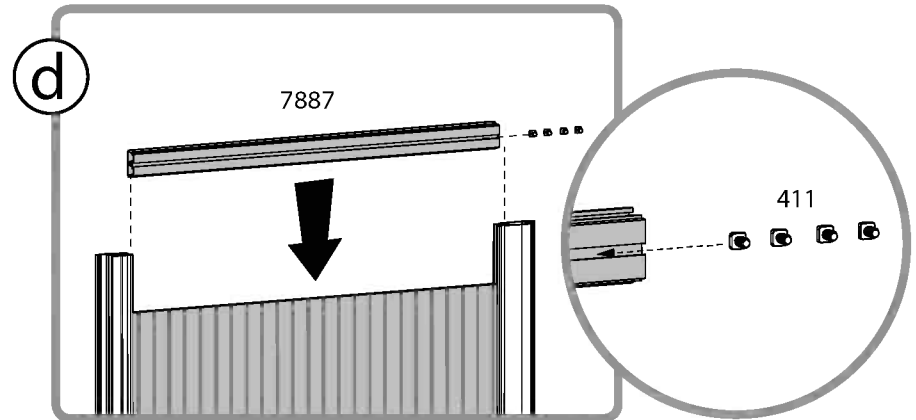
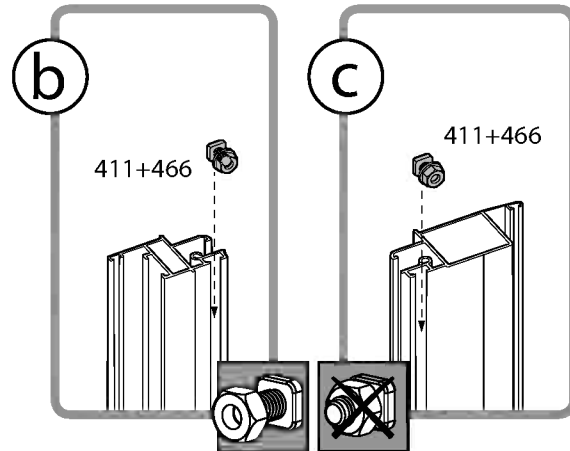
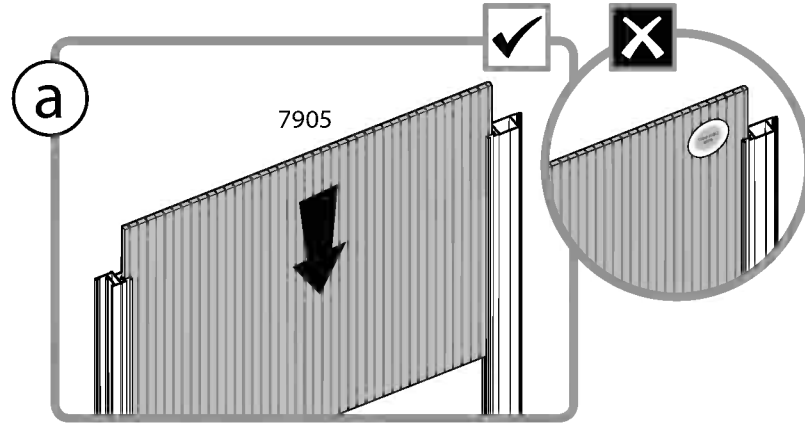
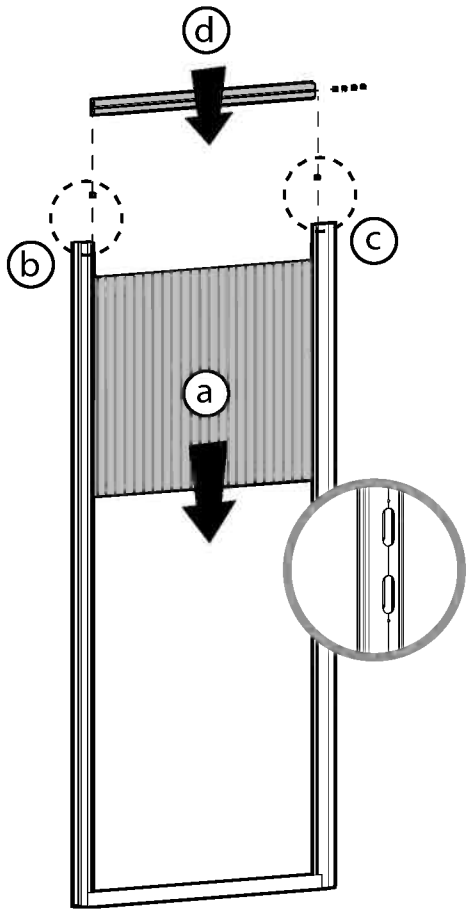
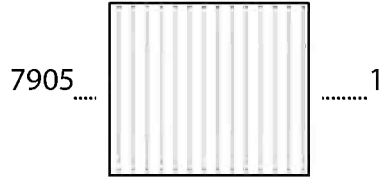
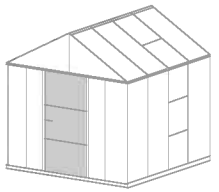

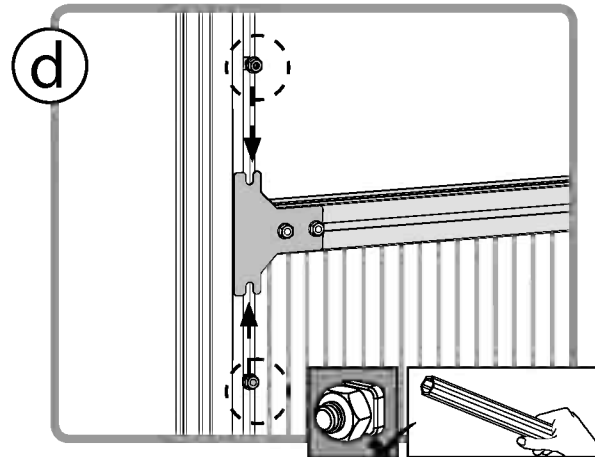
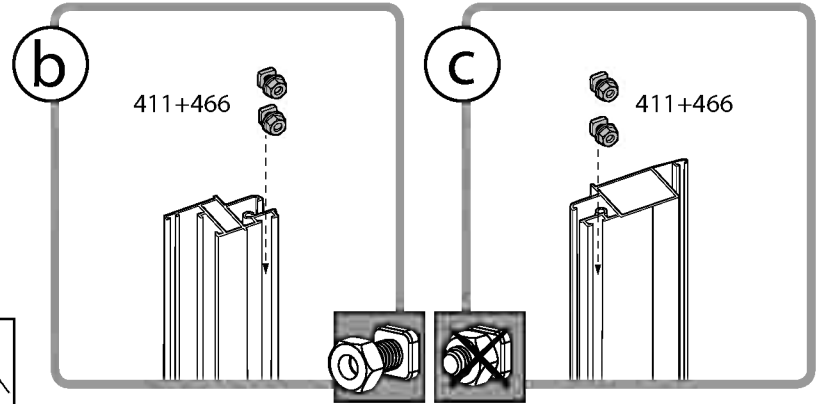
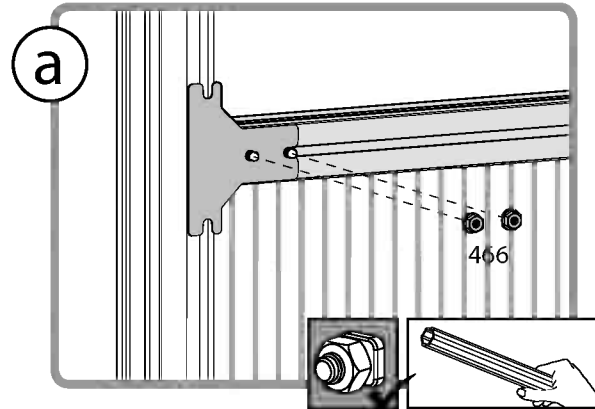
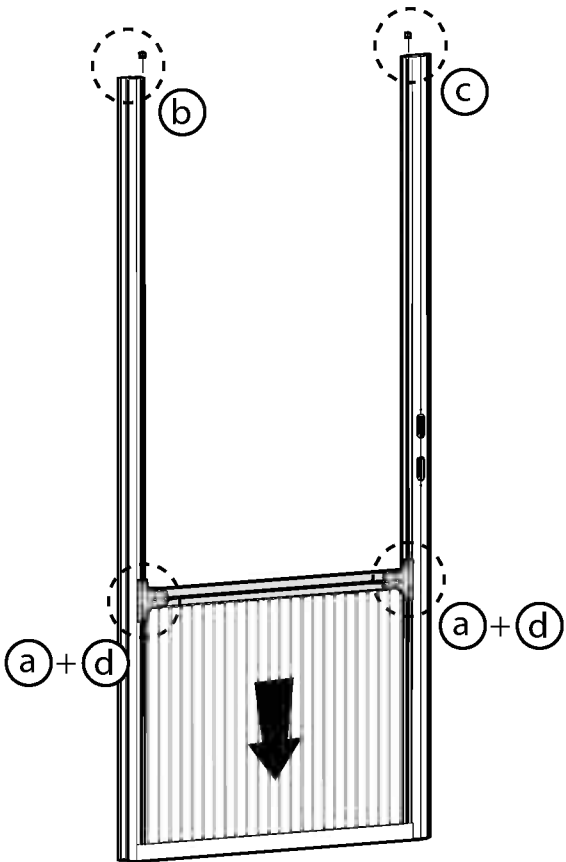
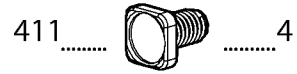
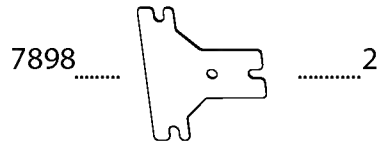
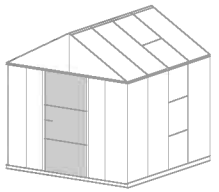

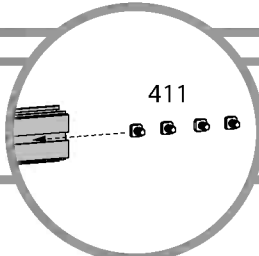
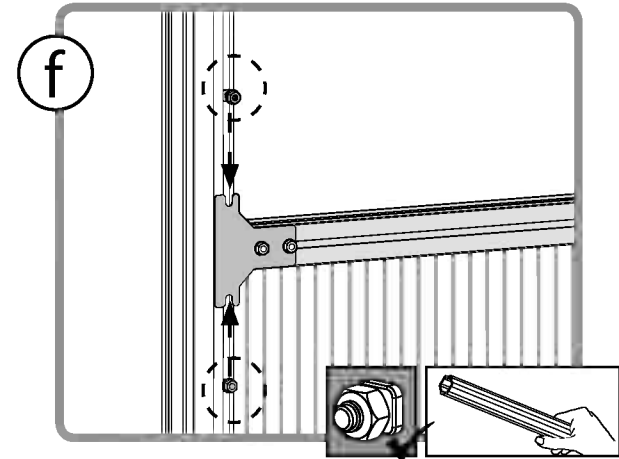
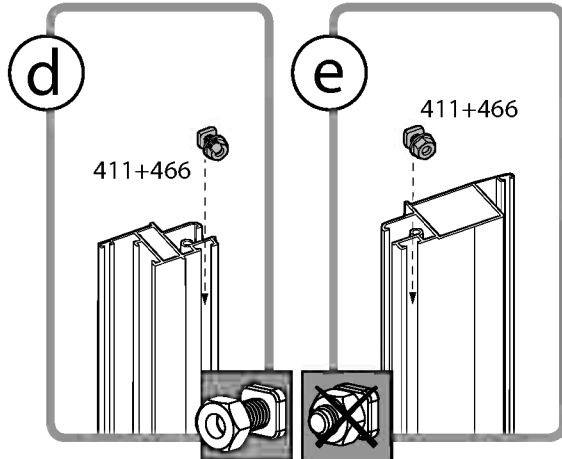
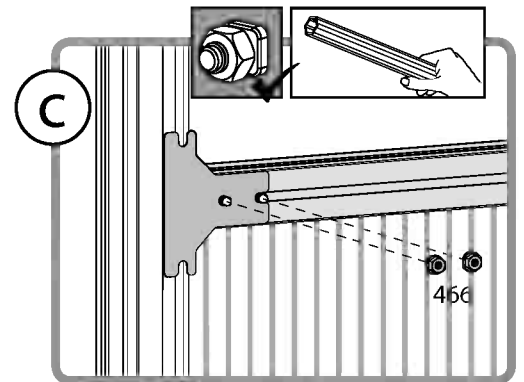
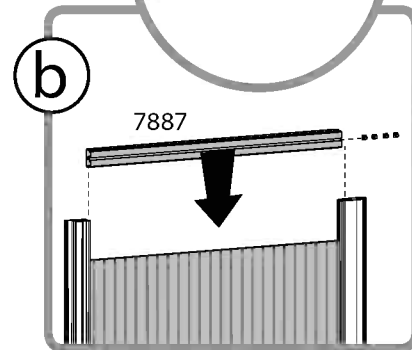
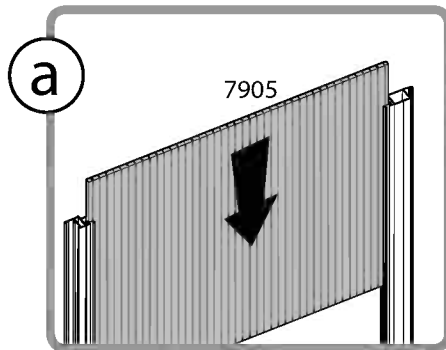
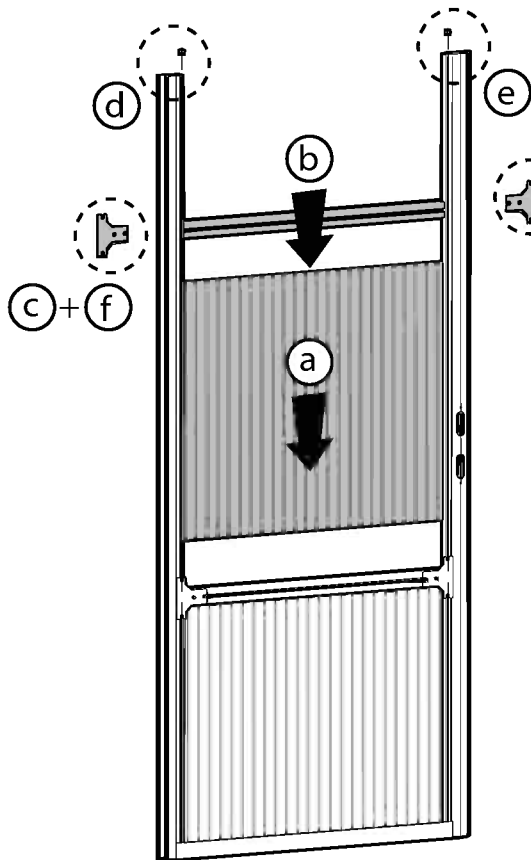
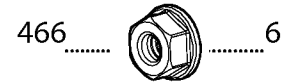
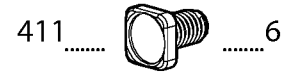
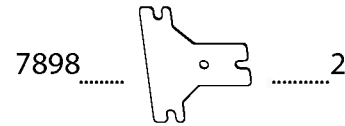
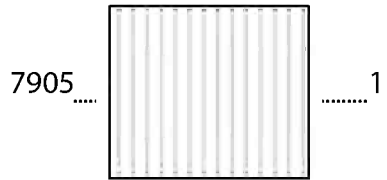
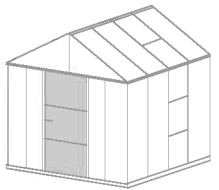

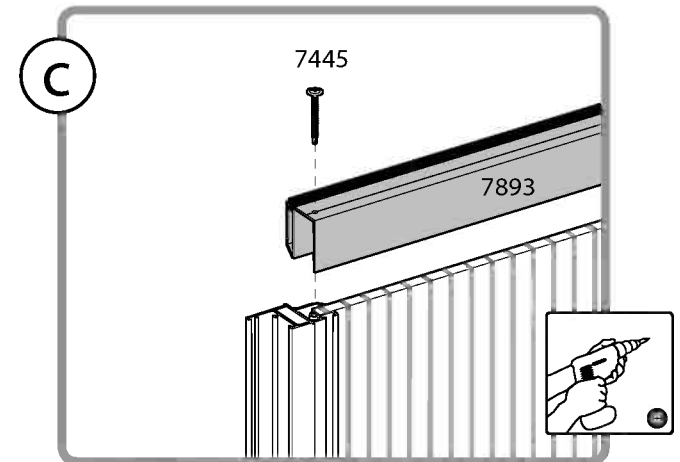
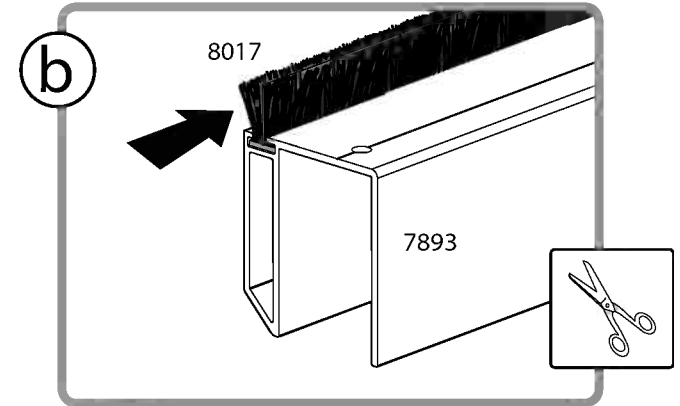
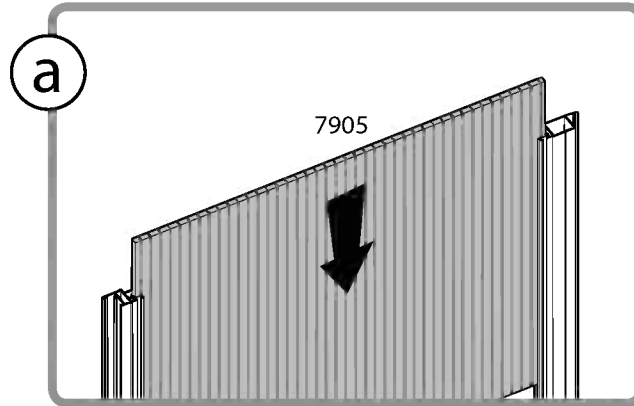
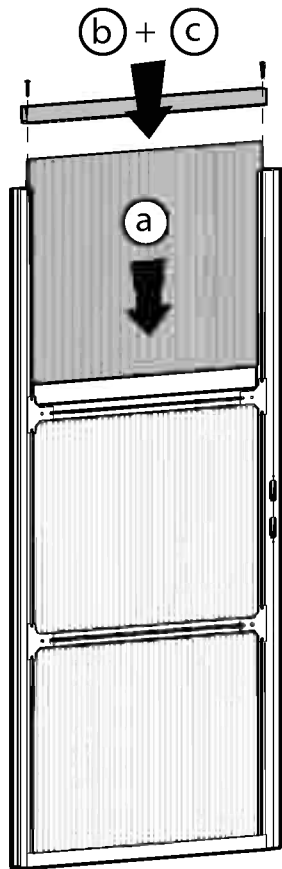
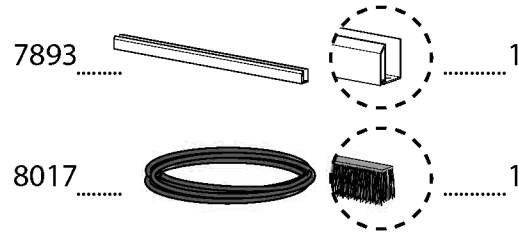
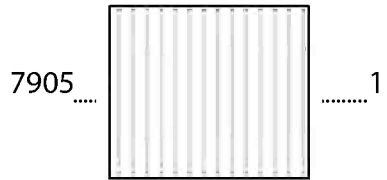
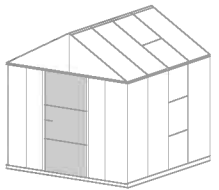

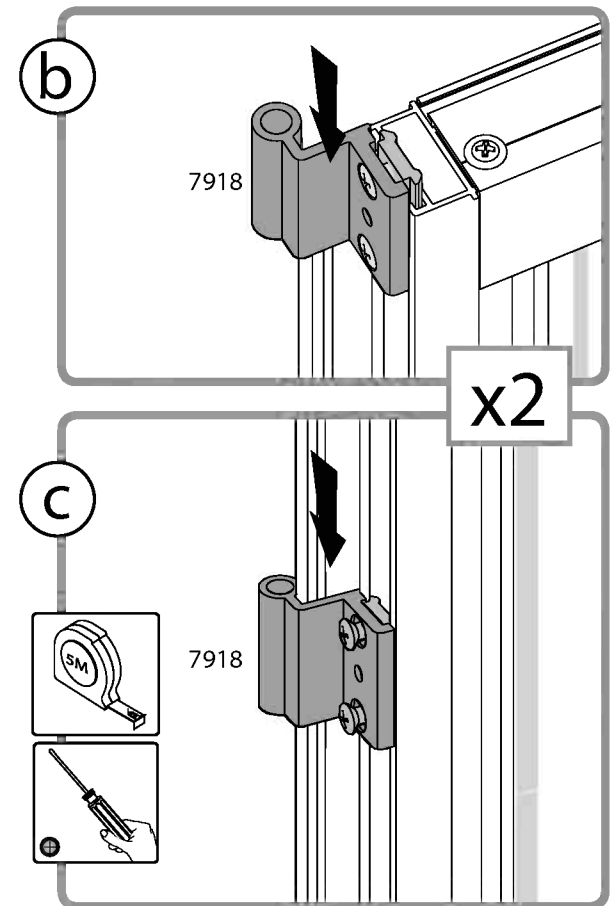
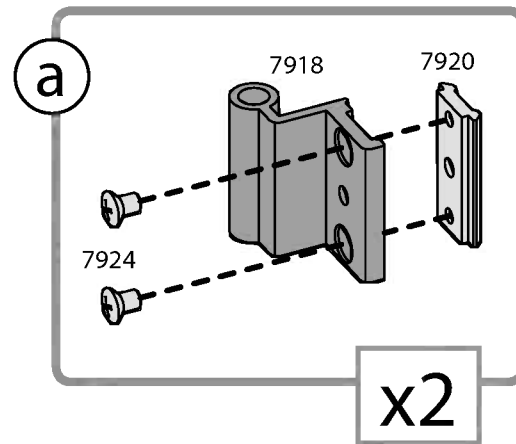
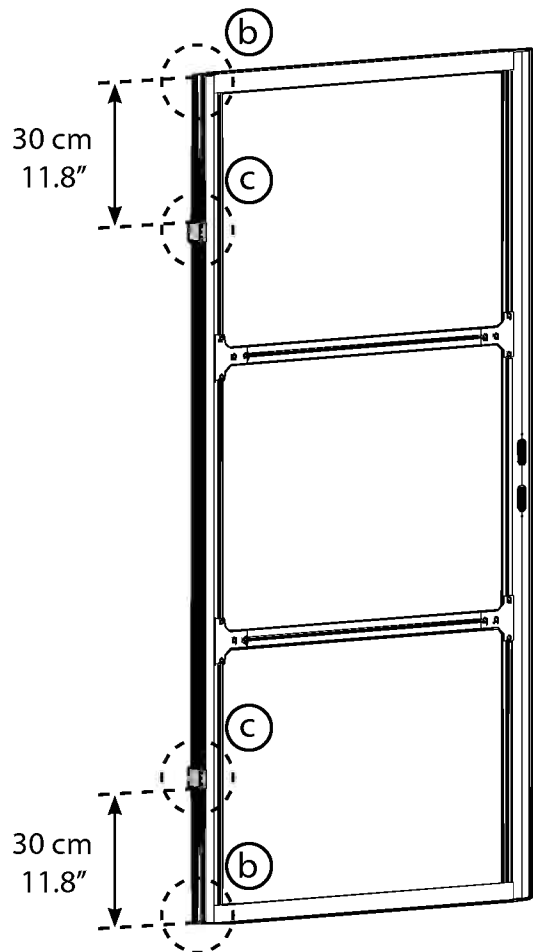
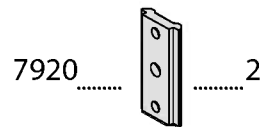
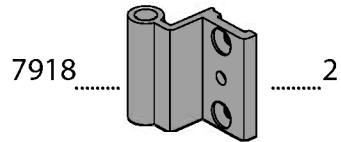
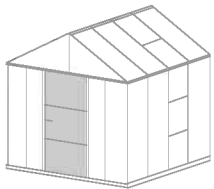

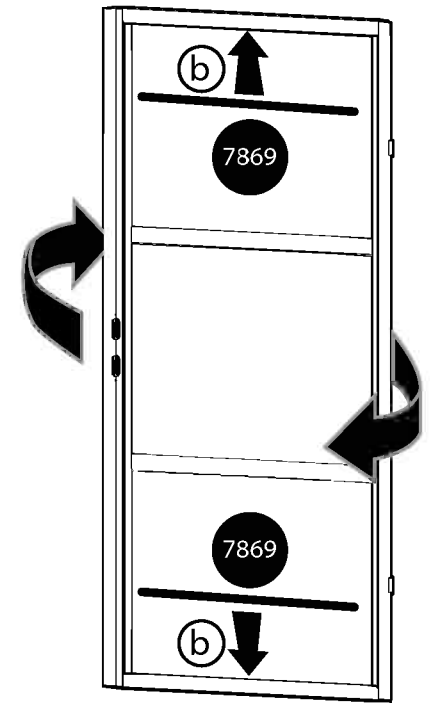
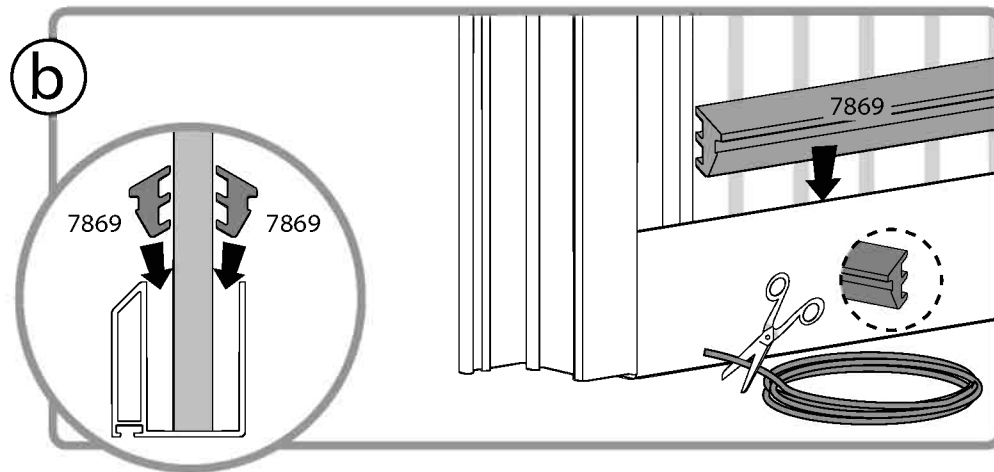
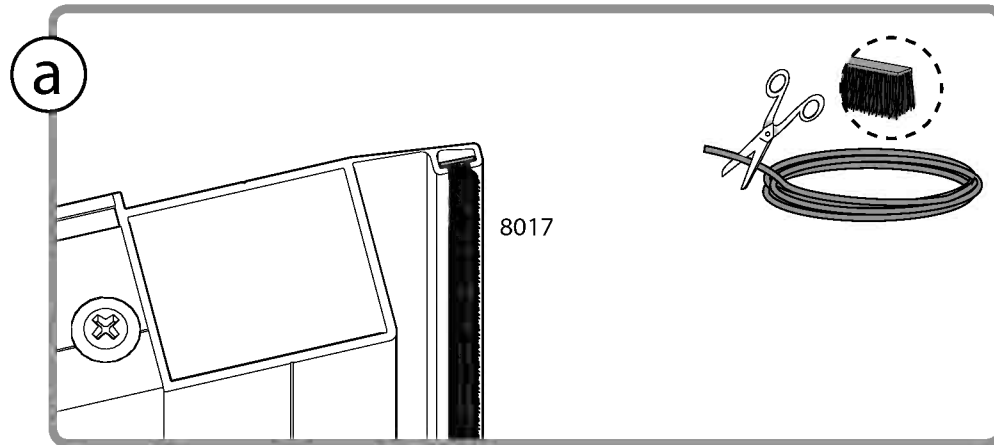
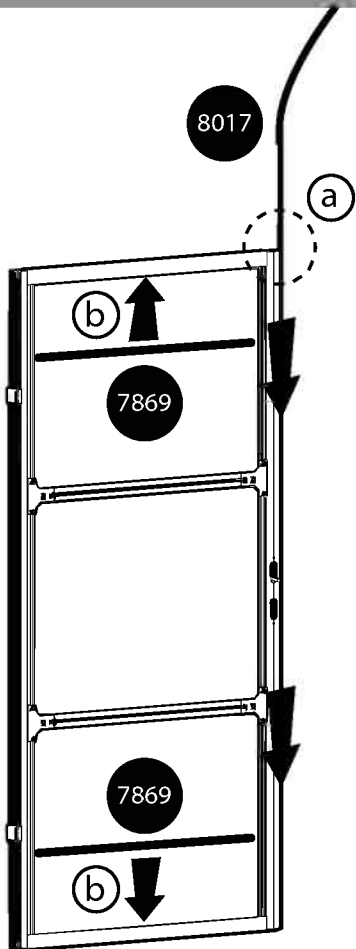
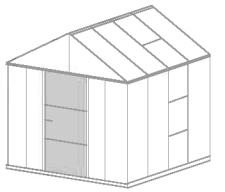



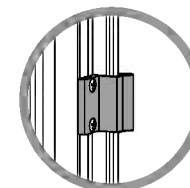
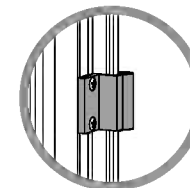
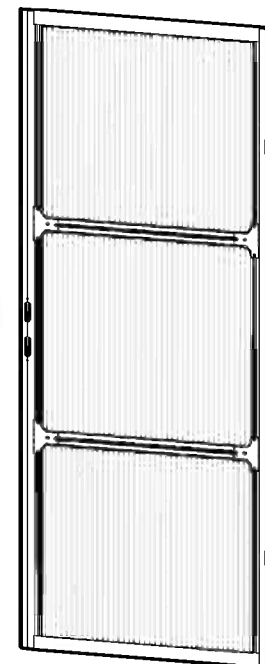
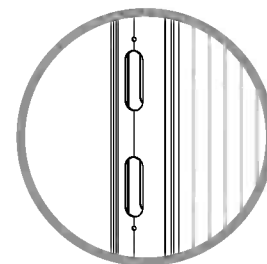
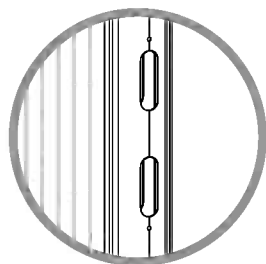
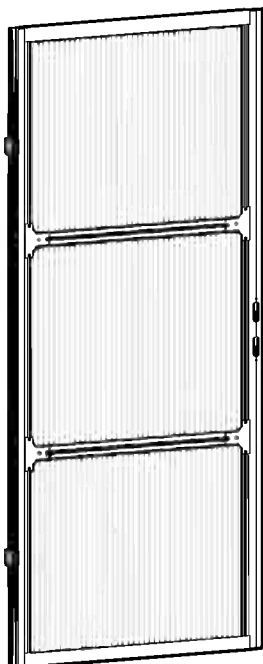
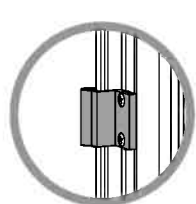
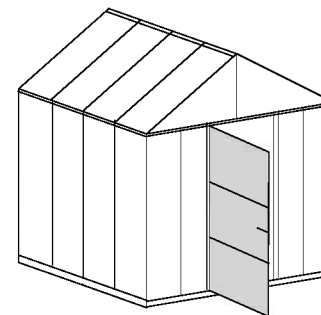
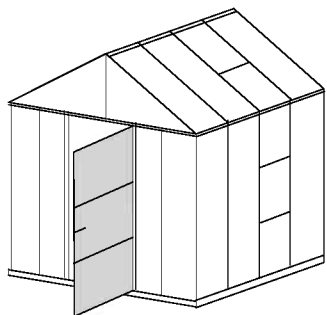
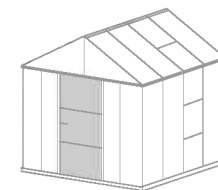

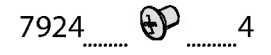
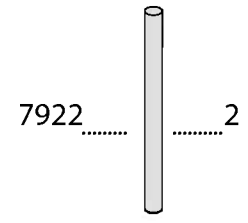
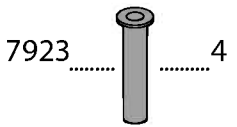
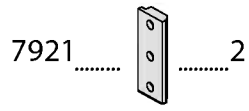
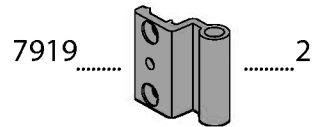
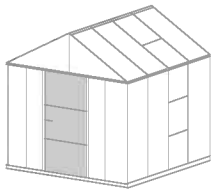

a

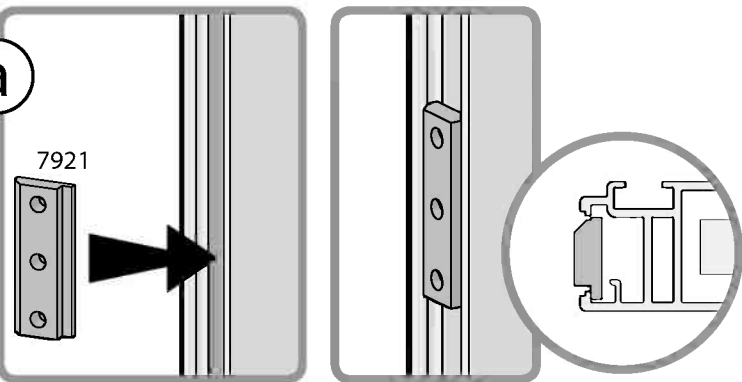

c

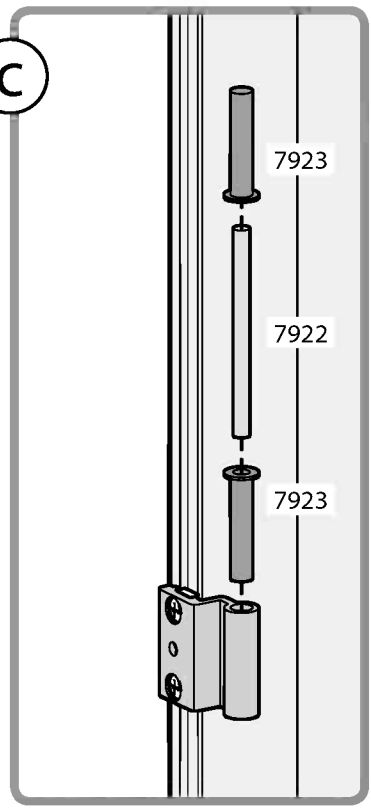

b

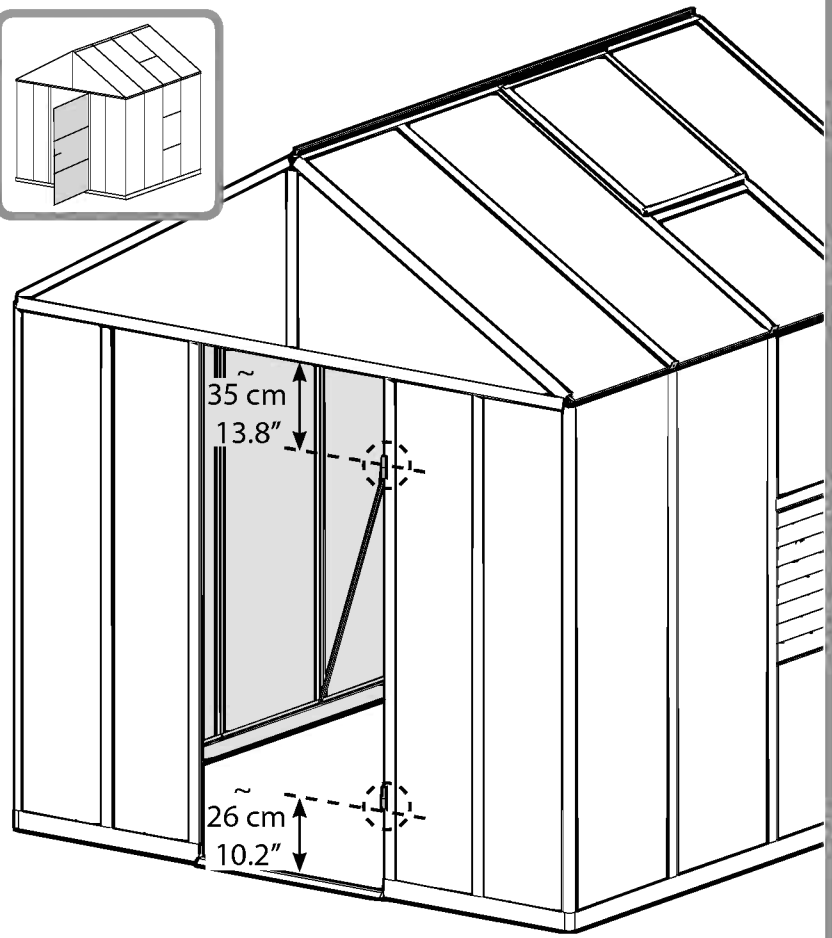
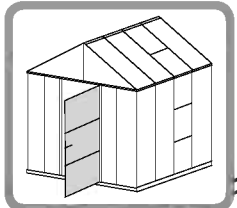
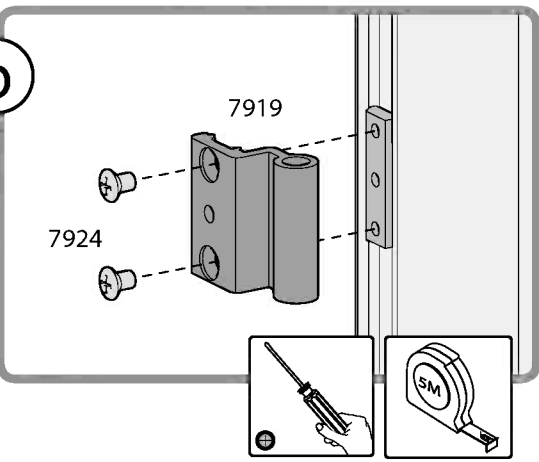

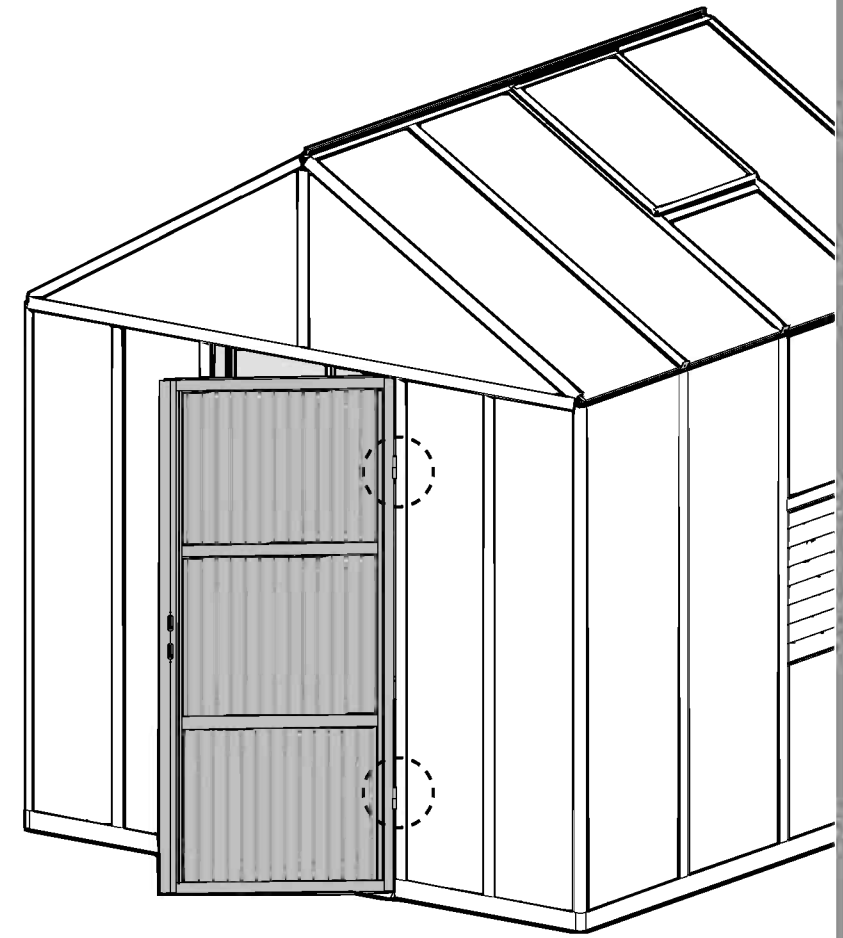
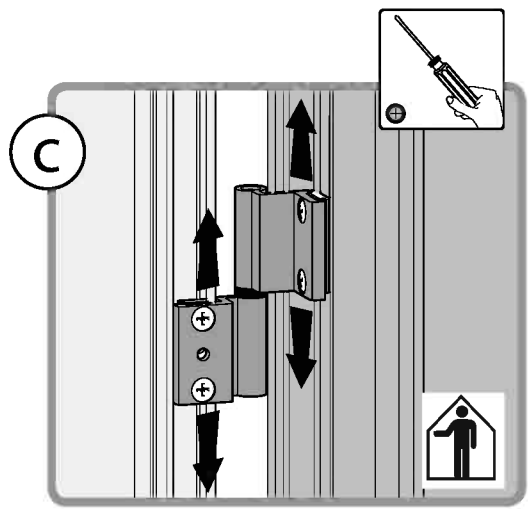
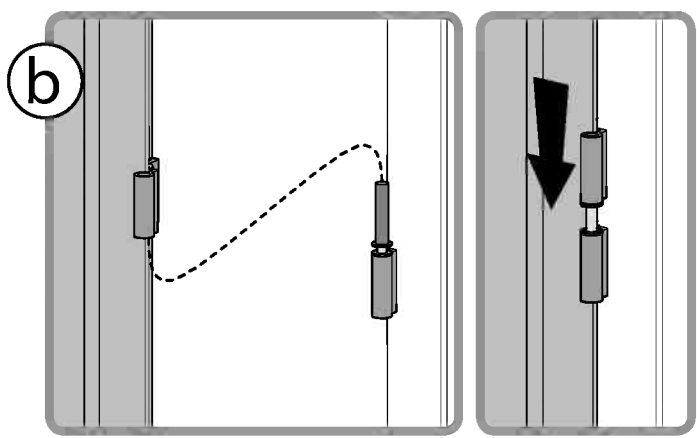
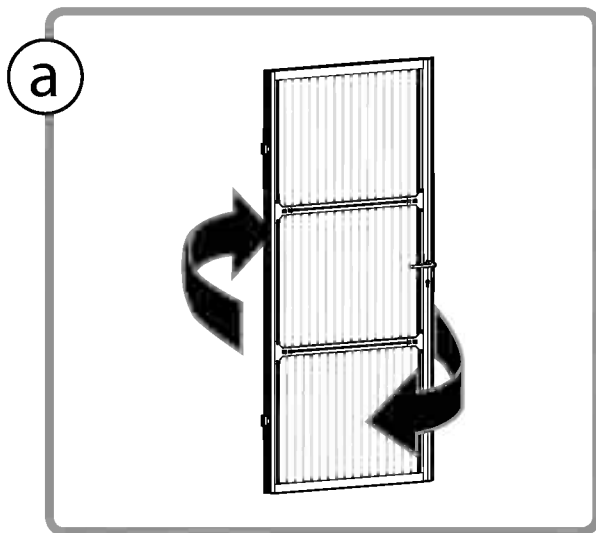
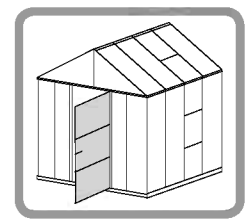
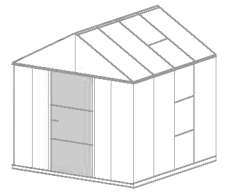

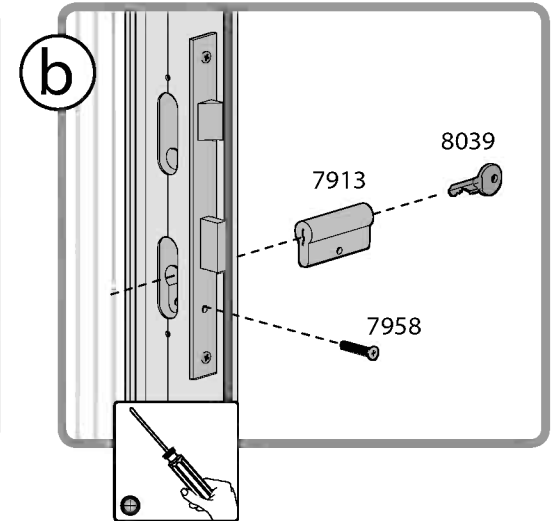
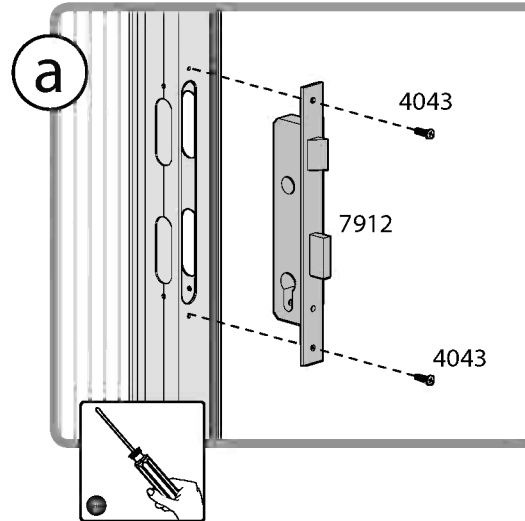
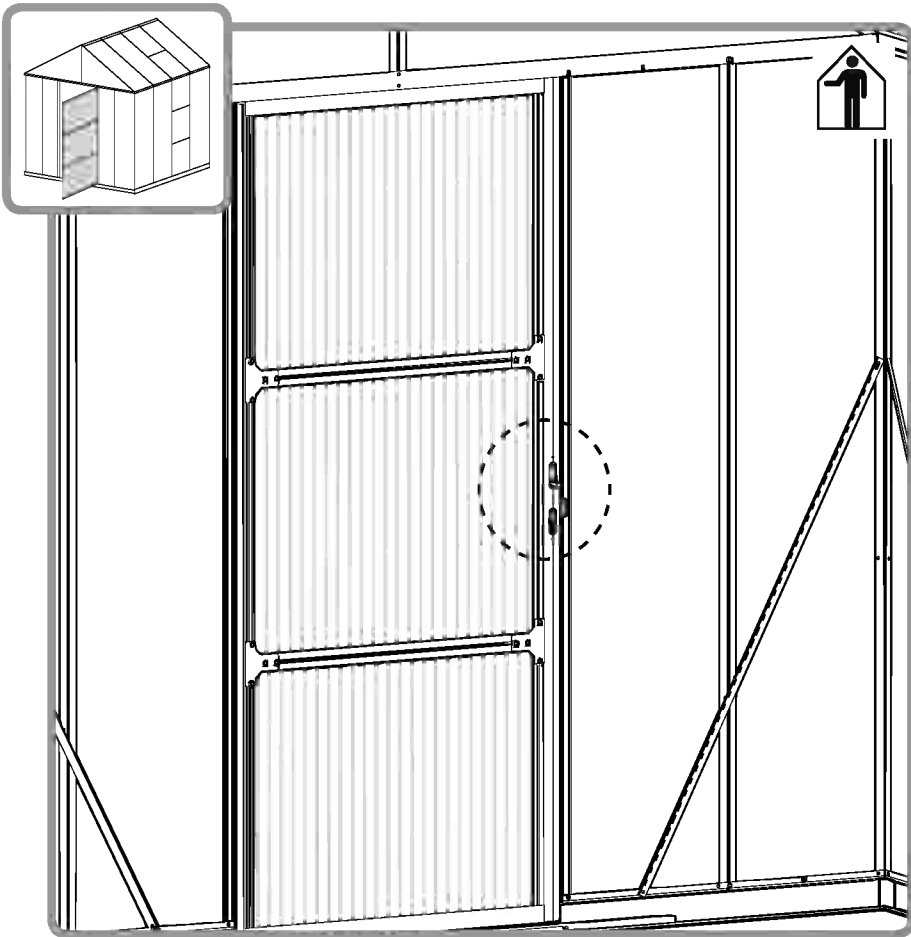
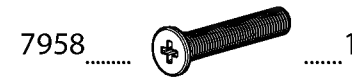
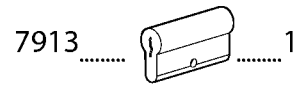
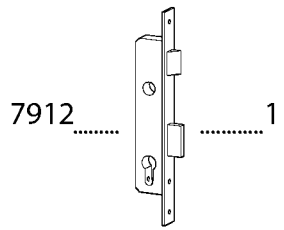
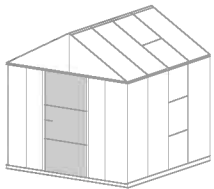

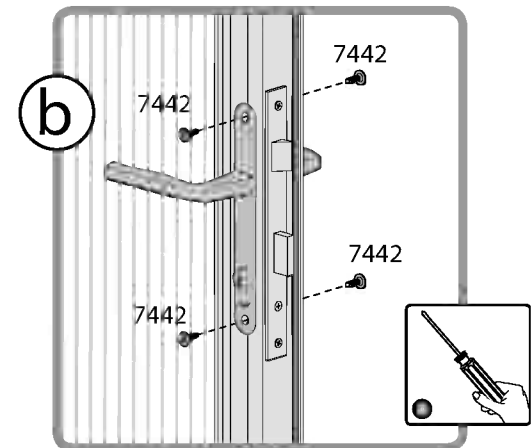
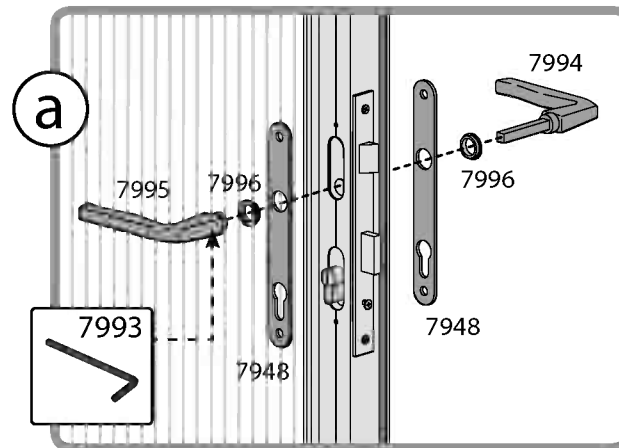
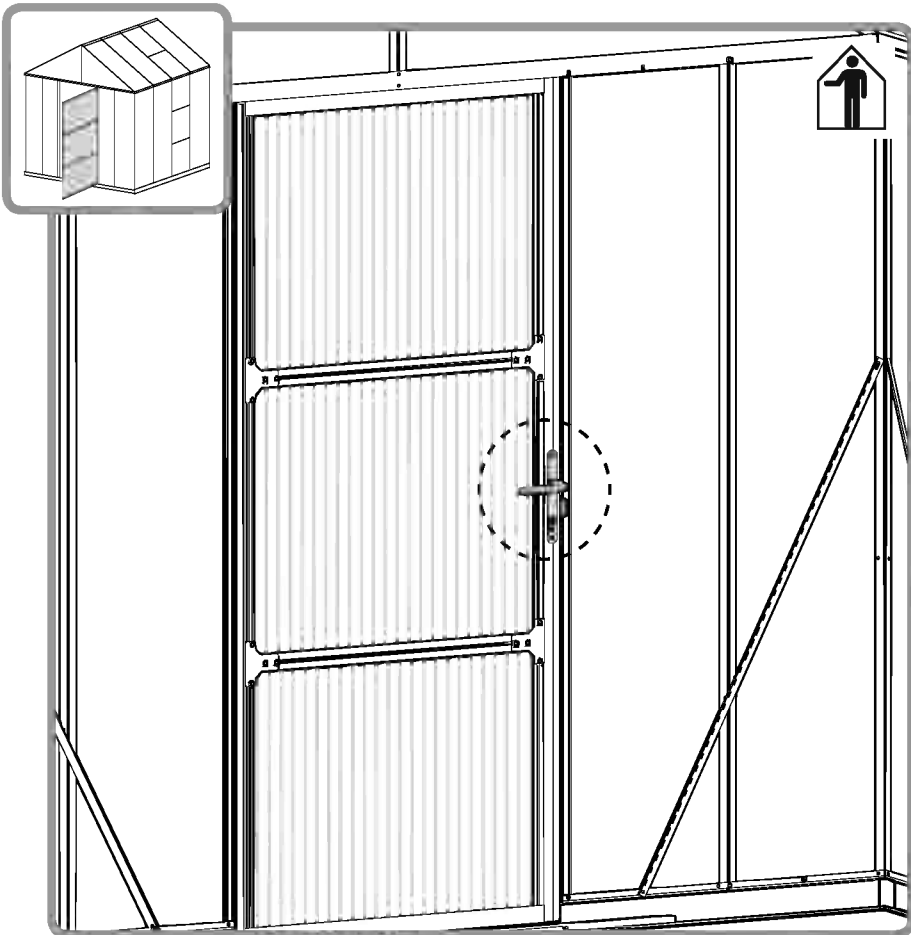
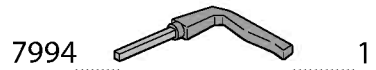
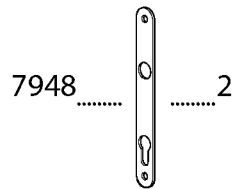
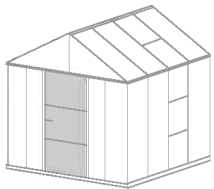

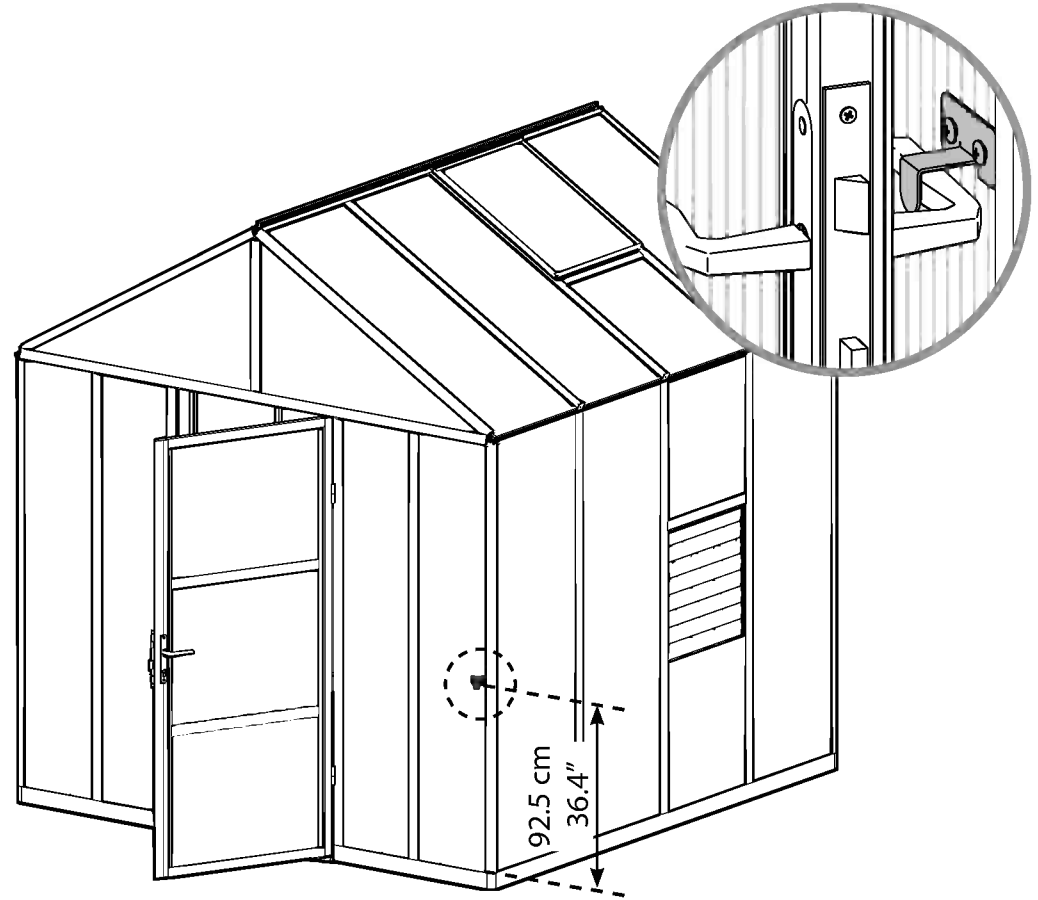
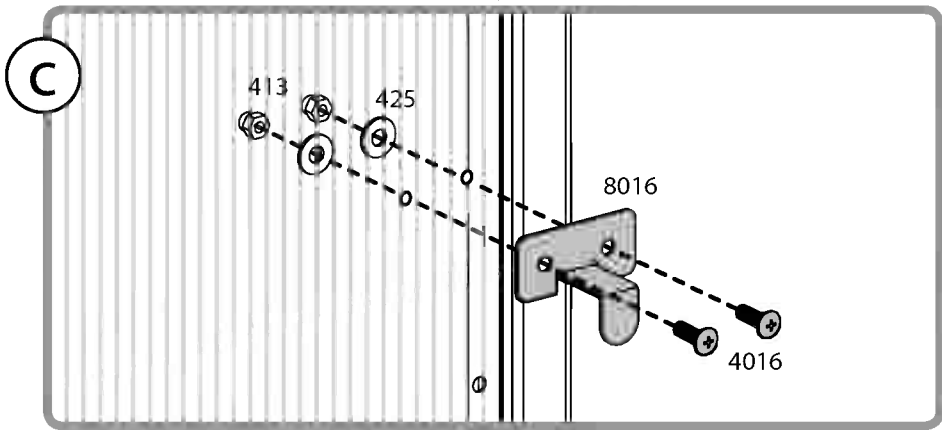
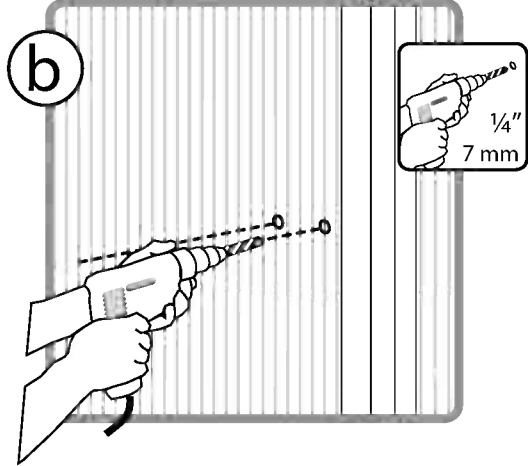
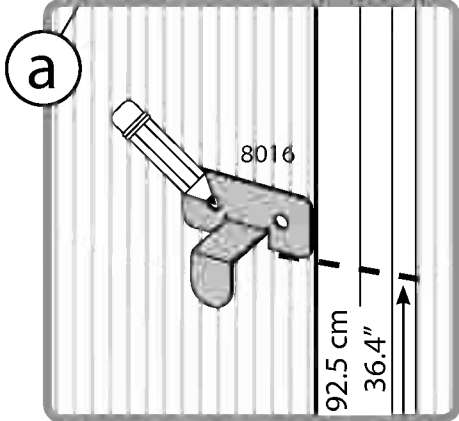
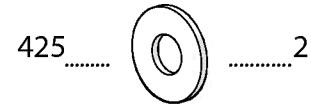
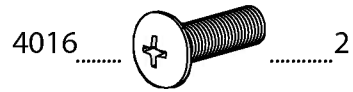
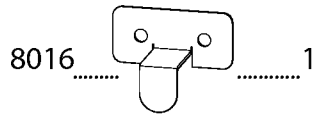
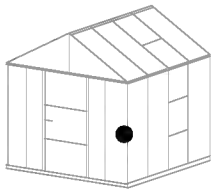

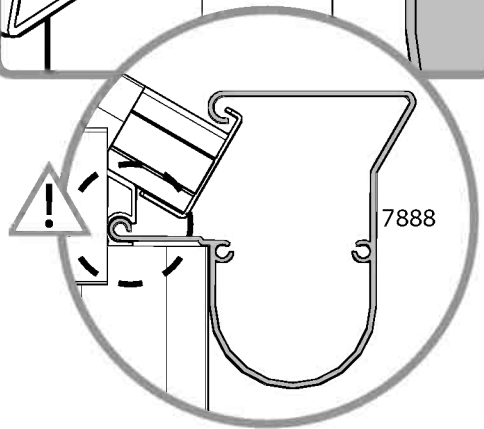
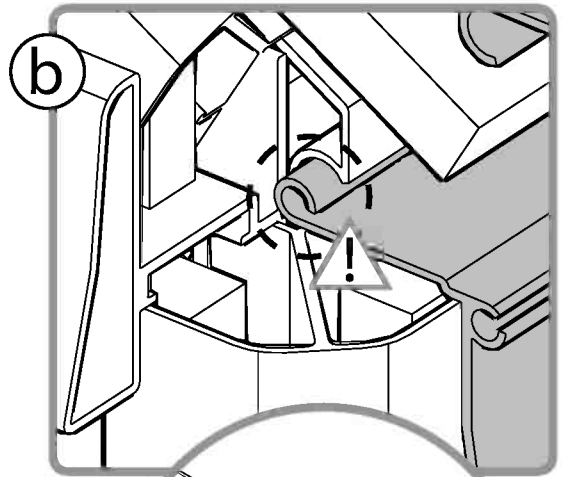
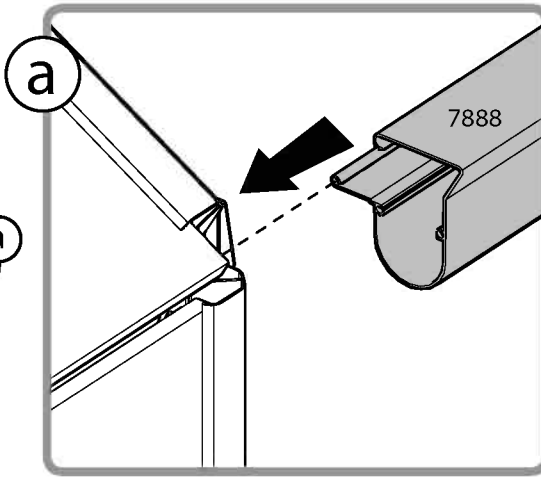
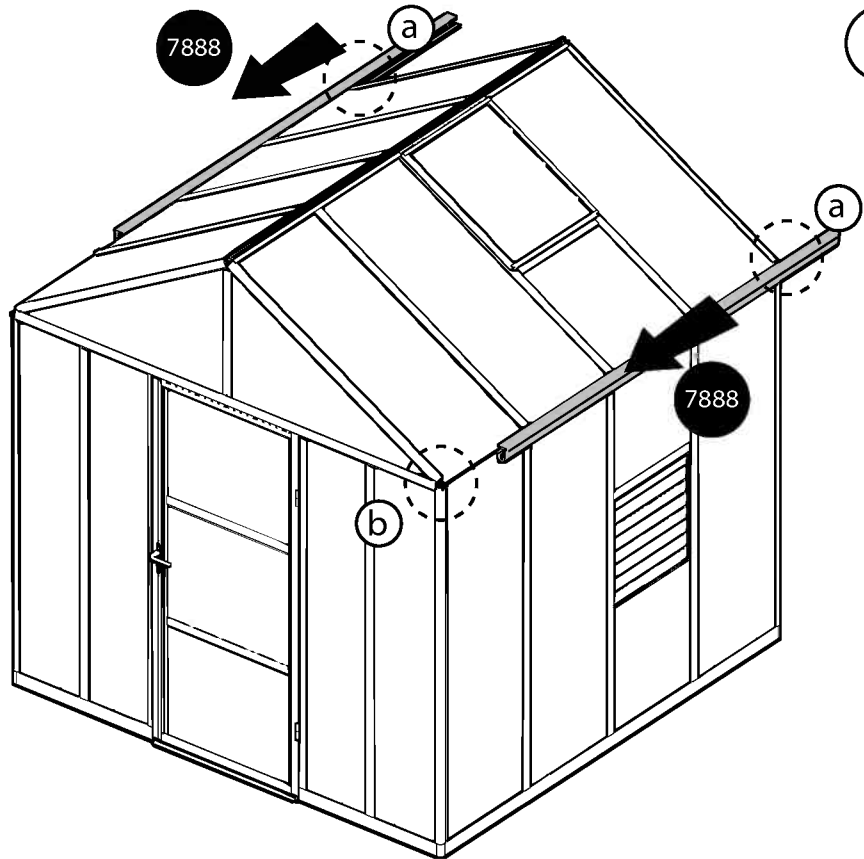
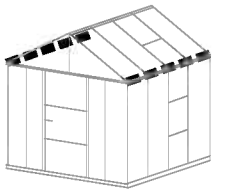

# 58 For Extension Kit Only

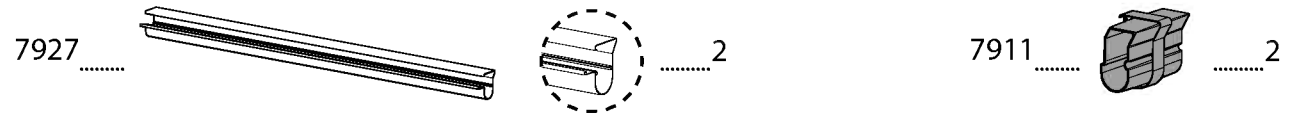
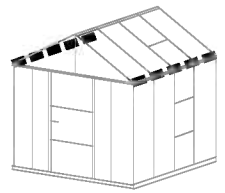

8'x12'  
(8'x8' + Extension)

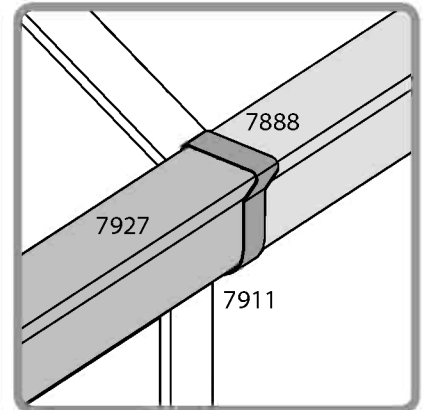
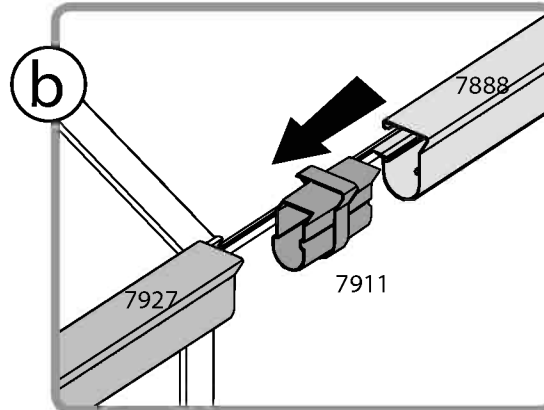
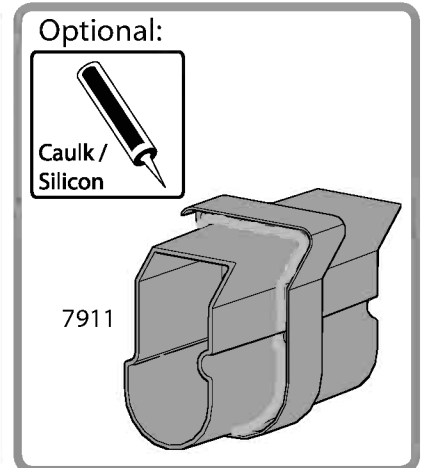
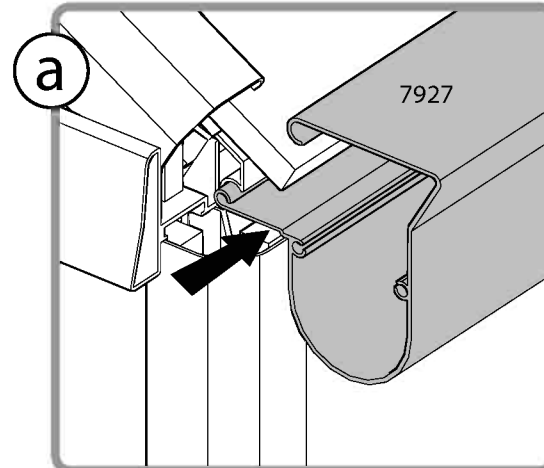
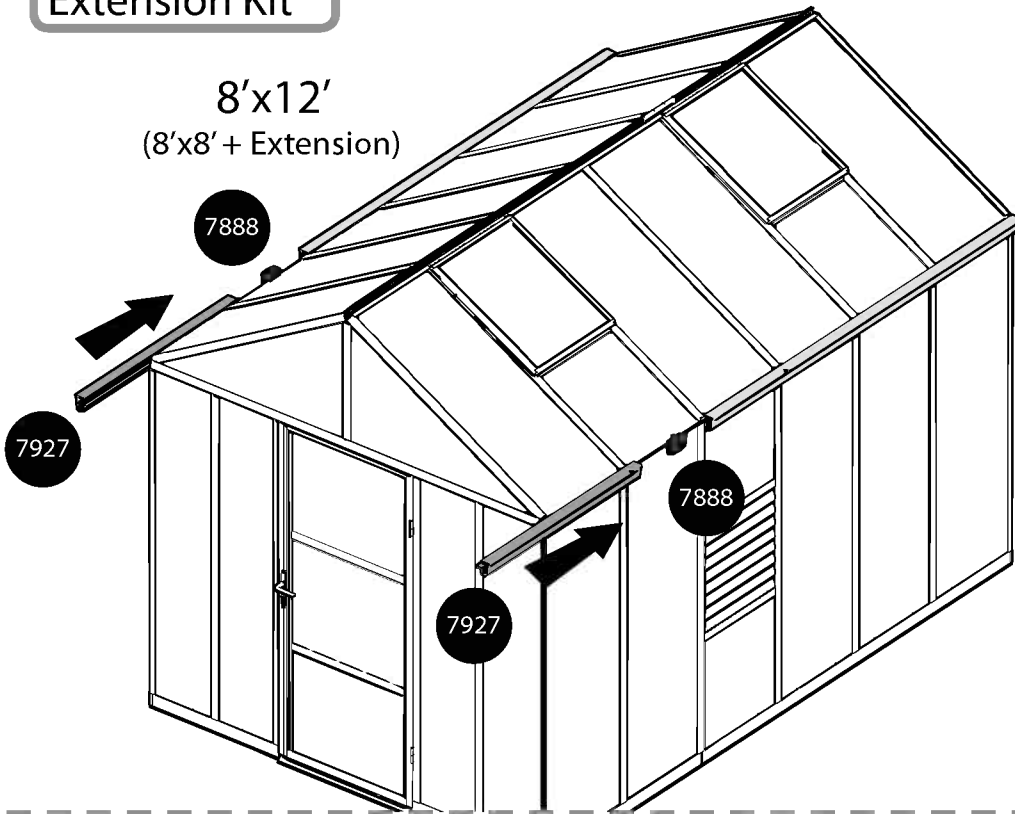



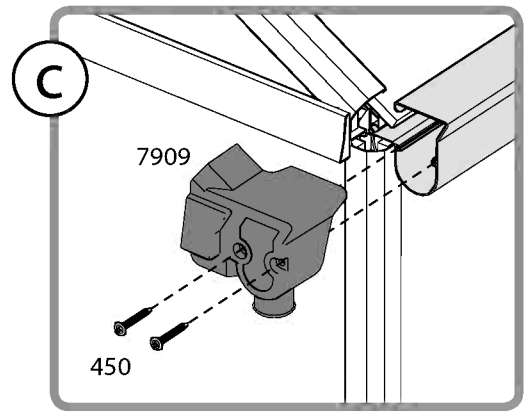
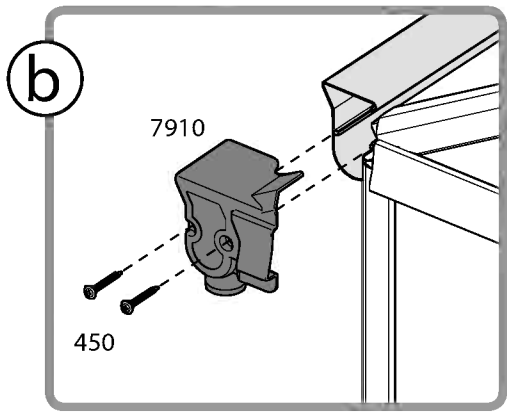
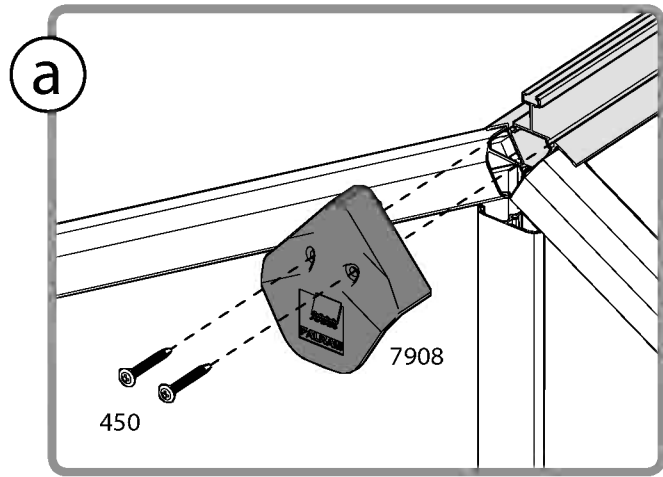
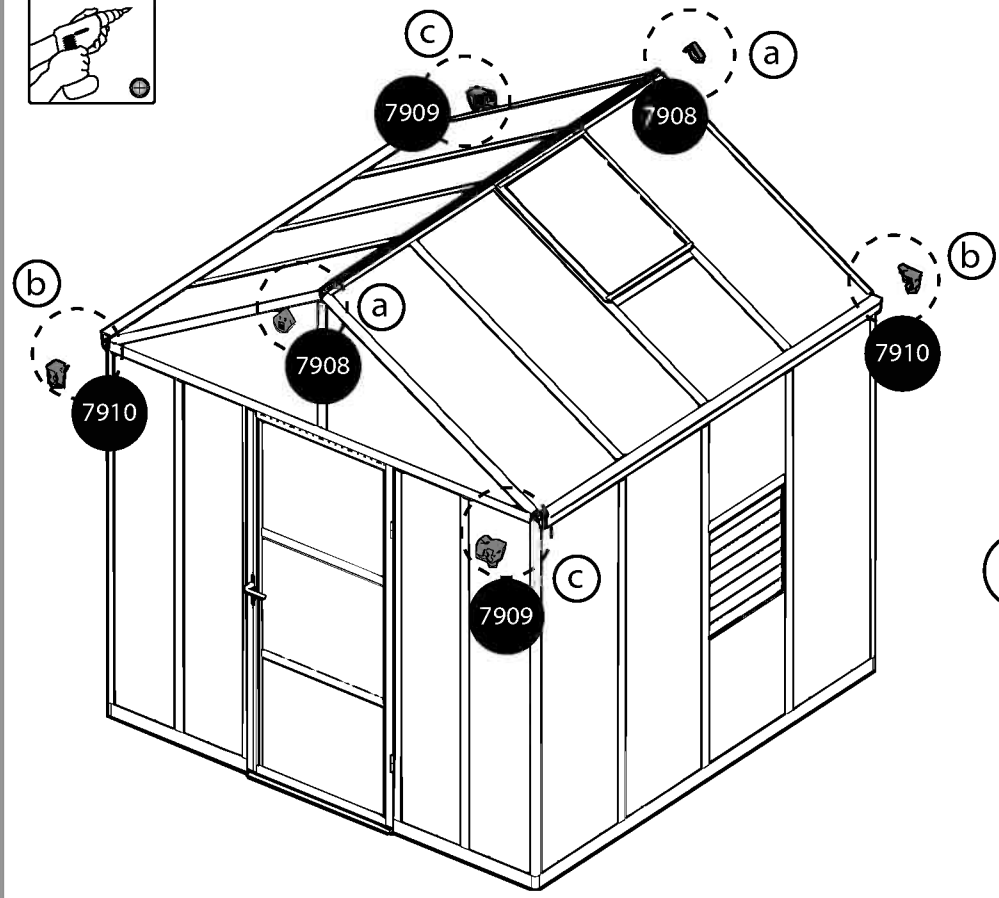
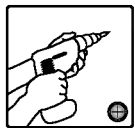
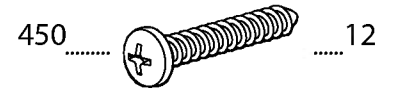
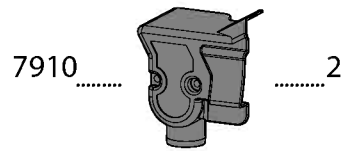
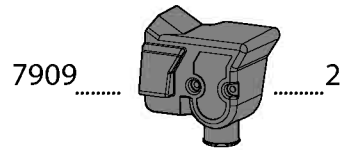
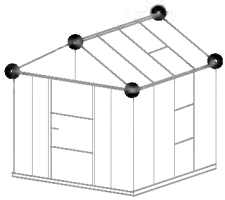

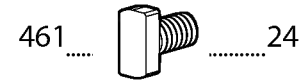
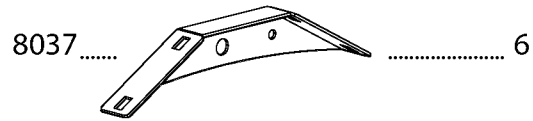
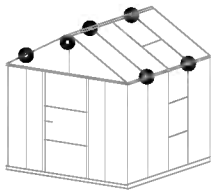

- 8037 ..... +3
- 466 ..... +12
- 461 ..... +12

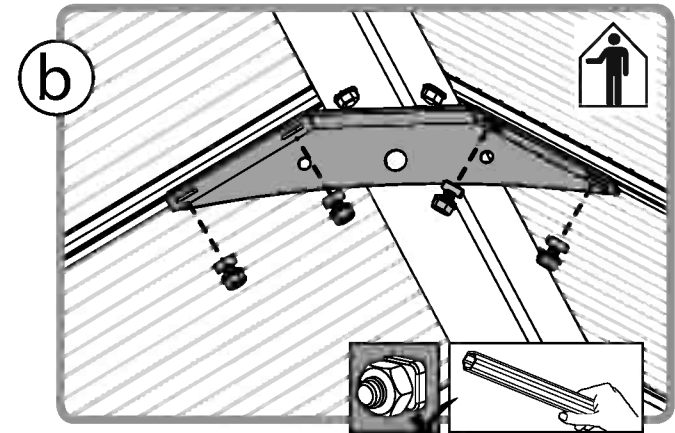
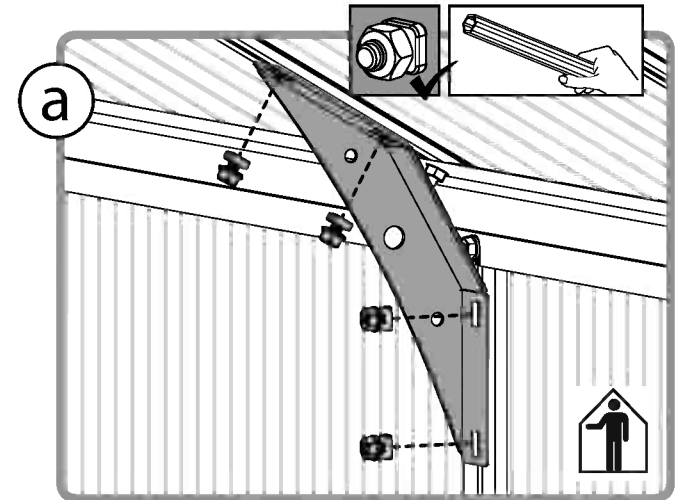
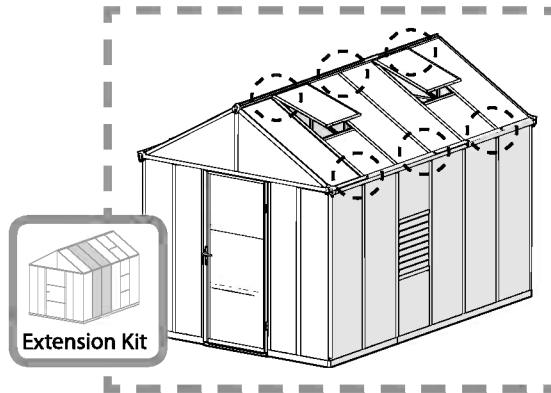
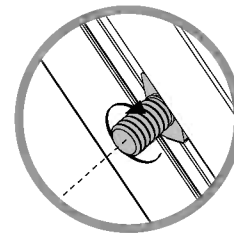
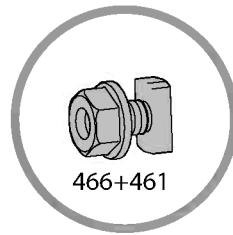
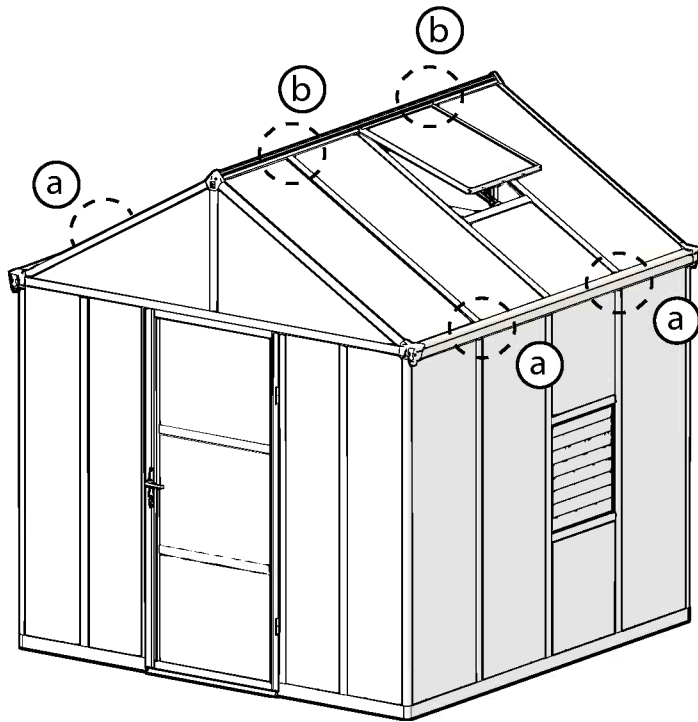

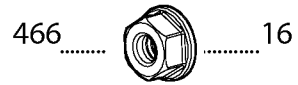
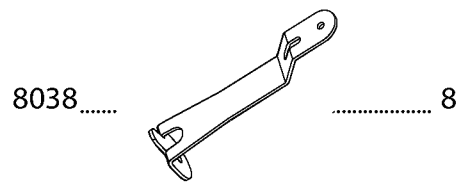
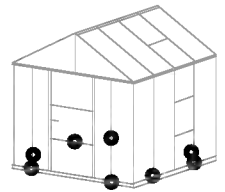

- 8038 ..... +2
- 466 ..... +4
- 433 ..... +4
- 4000 ..... +4
- 4010 ..... +4

